

# INSTRUCTION MANUAL

POWER LINE SUPER MULTI-METER

SQLC-110L

[ 1 $\phi$ 2W / 1 $\phi$ 3W / 3 $\phi$ 3W ANALOG OUTPUT ]

[ HARDWARE MODEL B [ Green backlight ]  
HARDWARE MODEL E [ White backlight ] ]

## Introduction

Thank you for your purchase of our product.

Read this instruction manual carefully before installation, wiring, and using this product.

Keep this instruction manual handy for reference at any time.

Have a contact with us or sales agent in case that this instruction manual is lost or damaged.

### <Caution>

Have a contact with us when you have any questions or are aware of missing article.

## Safety precaution

Important contents are mentioned in this instruction manual to prevent any damage/use this product appropriately.

Keep the following safety precaution in mind after understanding each sign.



**DANGER**

Improper use may lead to death or severe injury.



**WARNING**

Improper use may possibly lead to death or severe injury.



**ATTENTION**

Improper use may lead to medium injury.

- We are not responsible for the damage caused by following condition(earthquake/fire which is not caused by us, action by third party, other accident, damage caused by our customer, misuse, product usage under abnormal condition).
- We are not responsible for secondary damage caused by product use/product malfunction(loss of profit, halt of business operation). We are also not responsible for damage caused by false operation in combination with connecting equipment which is beyond our control.



**DANGER**

- Do not disassemble, remodel and repair this product.  
Have a contact with us or sales agent when product failure happens to prevent fire/electric shock/injury.
- Do not get this product wet to prevent heat generation/ignition/product failure. When this product gets wet, stop using it.
- Do not connect metal excepting wiring to terminal in order to prevent heat generation/ignition.
- Do not get this product near the inflammables/combustible chemicals/gas to prevent fire.



**WARNING**

- Connect specified power supply.  
Connecting power supply beyond specification causes fire/product failure.
- When dust is on the terminal, wipe it off after power is OFF to prevent fire.
- Follow the below-mentioned procedure when abnormality (fuming/bad odor) happens.
  - (1) Stop a power supply and input, and stop using.
  - (2) Contact our company or a distributing agent.



**ATTENTION**

- Do not use this product in a environment of high temperature/high humidity to prevent any damage.
- Do not touch the terminal during operation to prevent electric shock.
- Do not pull/bend connecting cable with force. Cable damage causes heat generation/burn and contact failure leads to equipment damage.
- Do not connect/inspect with wet hands to prevent electric shock.

## Cautions on safety



## Cautions on safe use

## 1. Working and storage environments

Don't mount or store this unit in the following environments. If the unit becomes defective due to the use in an environment other than specified, it may be repaired for pay even during its warranty period (one year after the date of delivery).

- ① Don't mount or store the unit at a place where the ambient temperature is other than a range of  $-10\sim+55^{\circ}\text{C}$  or the relative humidity is higher than 85% RH.
- ② Don't mount or store the unit at a place where a corrosive gas such as  $\text{SO}_2$ ,  $\text{H}_2\text{S}$ , etc. is generated.  
Corrosive gas = Sulfur dioxide  $\text{SO}_2$  / Hydrogen sulfide  $\text{H}_2\text{S}$  / etc.  
Large current bus / saturable reactor / etc.
- ③ Don't mount or store the unit at a dusty place.
- ④ Don't mount or store the unit at a place subjected to noticeable vibrations or shocks.
- ⑤ Don't mount or store the unit at a place subjected to noticeable external noises.
- ⑥ If this unit directly measures an inverter output of cycle control, SCR phase angle control or PWM control, an error may increase due to its operation principle.

## 2. Cautions on use in an outdoor panel

Be careful with the following items when using this unit in an outdoor panel.

- ① Don't mount the unit at a place where it is directly exposed to rain or water drops, otherwise this unit may become defective because of no water-proof or drip-proof structure.
- ② Don't mount the unit at a dusty place.
- ③ Don't mount the unit at a place exposed to direct sunlight. Avoid exposing the unit to direct sunlight even through a glass window.  
If the meter is directly exposed to sunlight, the surface temperature of the meter rises and the case may be deformed if the temperature exceeds  $80^{\circ}\text{C}$ .
- ④ If the average temperature around the meter exceeds  $40^{\circ}\text{C}$ , the life of the unit may shorten.

## 3. About dew condensation

If the temperature and humidity of an installation change rapidly when a product is a non-energization, the waterdrop by dew condensation may adhere to a display inner side. (The display filter and the LCD surface stick and the pattern of the shape of a circle or an ellipse occur.) This phenomenon is not trouble.  
It will disappear, if a control power supply is applied and about 2 hour passes.

## 4. Mounting and wiring

Mount and connect the unit by a technician while referring to the instruction manual and observing the following cautions.

|             |                                                                                                                                                                                                                                                                                                                                                                                                                                                                                                                                                                                                                                                                                                          |
|-------------|----------------------------------------------------------------------------------------------------------------------------------------------------------------------------------------------------------------------------------------------------------------------------------------------------------------------------------------------------------------------------------------------------------------------------------------------------------------------------------------------------------------------------------------------------------------------------------------------------------------------------------------------------------------------------------------------------------|
| <br>CAUTION | <ul style="list-style-type: none"> <li>● Connect the unit after confirming the connection diagram. An improper connection may cause troubles such as the generation of a high voltage on the secondary side of its current transformer or burning of the unit or the occurrence of a fire.</li> <li>● Don't perform any connection in a hot line without turning off the power supply in advance, otherwise an electric shock accident, troubles or burning of the unit, a fire, gas explosion, or other very dangerous accidents may occur.</li> <li>● The terminal cover is mounted for preventing an electric shock accident. Mount the terminal cover without fail after the end of work.</li> </ul> |
|-------------|----------------------------------------------------------------------------------------------------------------------------------------------------------------------------------------------------------------------------------------------------------------------------------------------------------------------------------------------------------------------------------------------------------------------------------------------------------------------------------------------------------------------------------------------------------------------------------------------------------------------------------------------------------------------------------------------------------|

## 5. Setting

This unit requires setting and confirmation of the measuring range, etc. before use. Wrong setting, if any, causes malfunction of the unit. If setting should be wrong, neither measurement nor output becomes correct.  
Carefully read the instruction manual before setting the unit.

■ Default setting

The default setting values are as specified below at the delivery time. Set them according to the working conditions. The input circuit of this product is the common use of 3-phase 3-wire ( $3\phi 3\text{W}$ ), single-phase 2-wire ( $1\phi 2\text{W}$ ), and single-phase 3-wire ( $1\phi 3\text{W}$ ). In case an input circuit is designated at the case of an order, it is shipped by the default value of the designated input circuit. And, in case it does not do designation of the input circuit (with no designation), it is shipped by the default value of 3-phase 3-wire.

The unit will be delivered with your specified setting values, if so specified.

## ① Voltage, current input (1/2)

| No. | Setting item                  |                                          | 3-phase 3-wire                          |                                                  | Single-phase 3-wire      | Single-phase                                     |                                                  |     |  |
|-----|-------------------------------|------------------------------------------|-----------------------------------------|--------------------------------------------------|--------------------------|--------------------------------------------------|--------------------------------------------------|-----|--|
|     |                               |                                          | 110V input                              | 220V input                                       |                          | 110V input                                       | 220V input                                       |     |  |
| 1   | Display combination           | Pattern                                  | Pattern 1                               |                                                  | Pattern 1                | Pattern 1                                        |                                                  |     |  |
|     |                               | Main monitor                             | A (Y)                                   |                                                  | A (R)                    | A                                                |                                                  |     |  |
|     |                               | Sub-monitor (Left)                       | V (RY)                                  |                                                  | V (RW)                   | V                                                |                                                  |     |  |
|     |                               | Sub-monitor (Center)                     | W                                       |                                                  | W                        | W                                                |                                                  |     |  |
|     |                               | Sub-monitor (Right)                      | Wh                                      |                                                  | Wh                       | Wh                                               |                                                  |     |  |
|     |                               | Bar graph                                | A (Y)                                   |                                                  | A (R)                    | A                                                |                                                  |     |  |
| 2   | Alarm output (1)              | Alarm 1                                  | Factor                                  | DA                                               |                          | DA                                               | DA                                               |     |  |
|     |                               |                                          | Reset form                              | AUTO                                             |                          | AUTO                                             | AUTO                                             |     |  |
|     |                               |                                          | Contact delay time                      | 0 second                                         |                          | 0 second                                         | 0 second                                         |     |  |
|     |                               |                                          | Test                                    | —                                                |                          | —                                                | —                                                |     |  |
|     |                               | Alarm 2                                  | Factor                                  | DA                                               |                          | DA                                               | DA                                               |     |  |
|     |                               |                                          | Reset form                              | AUTO                                             |                          | AUTO                                             | AUTO                                             |     |  |
|     |                               |                                          | Contact delay time                      | 0 second                                         |                          | 0 second                                         | 0 second                                         |     |  |
|     |                               |                                          | Test                                    | —                                                |                          | —                                                | —                                                |     |  |
| 3   | Demand detection              | Demand current                           | Upper limit value                       | 80.0A                                            |                          | 400A                                             | 40.0A                                            |     |  |
|     |                               |                                          | Interval                                | 0 second                                         |                          | 0 second                                         | 0 second                                         |     |  |
|     |                               | Demand active power                      | Upper limit value                       | OFF                                              |                          | OFF                                              | OFF                                              |     |  |
|     |                               |                                          | Interval                                | 0 second                                         |                          | 0 second                                         | 0 second                                         |     |  |
|     |                               |                                          | Operation form                          | Operating system according with bimetallic type. |                          | Operating system according with bimetallic type. | Operating system according with bimetallic type. |     |  |
|     |                               |                                          | Power-factor operation form             | Instant measurement                              |                          | Instant measurement                              | Instant measurement                              |     |  |
| 4   | Harmonic detection            | Current                                  | Distortion-factor upper limit           | OFF                                              |                          | OFF                                              | OFF                                              |     |  |
|     |                               |                                          | 5th conversion content rate upper limit | OFF                                              |                          | OFF                                              | OFF                                              |     |  |
|     |                               |                                          | n-th content rate                       | Factor                                           | 5th                      |                                                  | 5th                                              | 5th |  |
|     |                               |                                          |                                         | Upper limit                                      | OFF                      |                                                  | OFF                                              | OFF |  |
|     |                               | Voltage                                  | Distortion-factor upper limit           | OFF                                              |                          | OFF                                              | OFF                                              |     |  |
|     |                               |                                          | 5th conversion content rate upper limit | OFF                                              |                          | OFF                                              | OFF                                              |     |  |
|     |                               |                                          | n-th content rate                       | Factor                                           | 5th                      |                                                  | 5th                                              | 5th |  |
|     |                               |                                          |                                         | Upper limit                                      | OFF                      |                                                  | OFF                                              | OFF |  |
|     |                               | 5th conversion detection characteristics | Inverse-time-delay mode                 |                                                  | Inverse-time-delay mode  | Inverse-time-delay mode                          |                                                  |     |  |
|     |                               | Average value time limit                 | 0 minute                                |                                                  | 0 minute                 | 0 minute                                         |                                                  |     |  |
| 5   | Instant measurement detection | Voltage upper limit value                | OFF                                     |                                                  | OFF                      | OFF                                              |                                                  |     |  |
|     |                               | Voltage lower limit value                | OFF                                     |                                                  | OFF                      | OFF                                              |                                                  |     |  |
| 6   | Leakage detection (1)         | Rated sensitivity current                | 0.1A                                    |                                                  | 0.1A                     | 0.1A                                             |                                                  |     |  |
|     |                               | Factor switching                         | Io                                      |                                                  | Io                       | Io                                               |                                                  |     |  |
|     |                               | Circuit switching                        | 1 phase earthing                        |                                                  | 1 phase earthing         | 1 phase earthing                                 |                                                  |     |  |
|     |                               | Use ZCT selection                        | Type 0                                  |                                                  | Type 0                   | Type 0                                           |                                                  |     |  |
| 7   | Backlight                     | Action                                   | AUTO                                    |                                                  | AUTO                     | AUTO                                             |                                                  |     |  |
|     |                               | Brightness (2)                           | 3 (Middle)                              |                                                  | 3 (Middle)               | 3 (Middle)                                       |                                                  |     |  |
| 8   | Measurement range             | Voltage range                            | 6600V                                   | 220V                                             | 110.0V                   | 3300V                                            | 220V                                             |     |  |
|     |                               | Current range                            | 100.0A                                  |                                                  | 500A                     | 50.0A                                            |                                                  |     |  |
|     |                               | Current display peculiar sensitivity     | 100.0A                                  |                                                  | 500A                     | 50.0A                                            |                                                  |     |  |
|     |                               | Active power polarity                    | One-side swing                          |                                                  | One-side swing           | One-side swing                                   |                                                  |     |  |
|     |                               | Active power range                       | 1200kW                                  | 40.0kW                                           | 100.0kW                  | 150.0kW                                          | 10.00kW                                          |     |  |
|     |                               | Reactive power range                     | 600kvar                                 | 20.00kvar                                        | 50.0kvar                 | 75.0kvar                                         | 5.00kvar                                         |     |  |
|     |                               | Power-factor range                       | LEADO.500~1.000~LAGO.500                |                                                  | LEADO.500~1.000~LAGO.500 | LEADO.500~1.000~LAGO.500                         |                                                  |     |  |
|     |                               | Frequency range                          | 45.0~65.0Hz                             |                                                  | 45.0~65.0Hz              | 45.0~65.0Hz                                      |                                                  |     |  |
| 9   | Analog output (1)             | Output factor 1                          | A (Y)                                   |                                                  | A (R)                    | A                                                |                                                  |     |  |
|     |                               | Output factor 2                          | V (RY)                                  |                                                  | V (RW)                   | V                                                |                                                  |     |  |
|     |                               | Output factor 3                          | W                                       |                                                  | W                        | W                                                |                                                  |     |  |
|     |                               | Output factor 4                          | cos φ                                   |                                                  | cos φ                    | cos φ                                            |                                                  |     |  |
|     |                               | Output peculiar sensitivity              | Current                                 | 100.0%                                           |                          | 100.0%                                           | 100.0%                                           |     |  |
|     |                               |                                          | Active power                            | 100.0%                                           |                          | 100.0%                                           | 100.0%                                           |     |  |
|     |                               |                                          | Reactive power                          | 50.0%                                            |                          | 50.0%                                            | 50.0%                                            |     |  |
|     |                               | Low input cut                            | OFF                                     |                                                  | OFF                      | OFF                                              |                                                  |     |  |

Note(1) A setting item is not displayed in case there is no corresponding option.

Note(2) In the case of green backlight, it does not indicate the setting item of brightness.

## ① Voltage, current input (2/2)

| No.                              | Setting item                                                  |                                    | 3-phase 3-wire  |                     | Single-phase 3-wire | Single-phase        |            |          |  |
|----------------------------------|---------------------------------------------------------------|------------------------------------|-----------------|---------------------|---------------------|---------------------|------------|----------|--|
|                                  |                                                               |                                    | 110V input      | 220V input          |                     | 110V input          | 220V input |          |  |
| 10                               | Pulse output<br>( <sup>3</sup> )                              | Output 1                           | Factor          | Wh                  |                     | Wh                  | Wh         |          |  |
|                                  |                                                               |                                    | Pulse unit      | 10kWh/p             | 0.1kWh/p            | 1kWh/p              | 1kWh/p     | 0.1kWh/p |  |
|                                  | Output 2                                                      | Factor                             | Wh              |                     | Wh                  | Wh                  |            |          |  |
|                                  |                                                               | Pulse unit                         | 10kWh/p         | 0.1kWh/p            | 1kWh/p              | 1kWh/p              | 0.1kWh/p   |          |  |
| 11                               | External operation<br>input ( <sup>3</sup> )                  | Input 1 function                   |                 | Alarm reset         |                     | Alarm reset         |            |          |  |
|                                  |                                                               | Input 2 function                   |                 | Max./Min. reset     |                     | Max./Min. reset     |            |          |  |
| 12                               | Measurement display<br>ON/OFF                                 | Voltage                            |                 | ON                  |                     | ON                  |            |          |  |
|                                  |                                                               | Current                            |                 | ON                  |                     | ON                  |            |          |  |
|                                  |                                                               | Active power                       |                 | ON                  |                     | ON                  |            |          |  |
|                                  |                                                               | Reactive power                     |                 | ON                  |                     | ON                  |            |          |  |
|                                  |                                                               | Power-factor                       |                 | ON                  |                     | ON                  |            |          |  |
|                                  |                                                               | Frequency                          |                 | ON                  |                     | ON                  |            |          |  |
|                                  |                                                               | Watt-hour of power receiving       |                 | ON                  |                     | ON                  |            |          |  |
|                                  |                                                               | Watt-hour of power transmission    |                 | ON                  |                     | ON                  |            |          |  |
|                                  |                                                               | var-hour of power receiving        |                 | ON                  |                     | ON                  |            |          |  |
|                                  |                                                               | var-hour of power transmission     |                 | ON                  |                     | ON                  |            |          |  |
|                                  |                                                               | Harmonic current                   |                 | ON                  |                     | ON                  |            |          |  |
|                                  |                                                               | Harmonic voltage                   |                 | ON                  |                     | ON                  |            |          |  |
| Current leakage ( <sup>3</sup> ) |                                                               | ON                                 |                 | ON                  |                     | ON                  |            |          |  |
| 13                               | Input circuit                                                 | Phase line change ( <sup>5</sup> ) |                 | 3 $\phi$ 3W         |                     | 1 $\phi$ 3W (R-W-B) |            |          |  |
|                                  |                                                               | Input voltage ( <sup>6</sup> )     |                 | 110V                | 220V                | 300V                | 110V       | 220V     |  |
| 14                               | Measurement                                                   | Dead band                          |                 | 0.0%                |                     | 0.0%                |            |          |  |
|                                  |                                                               | Tidal current measurement          |                 | General measurement |                     | General measurement |            |          |  |
| 15                               | Analog output specification ( <sup>3</sup> ) ( <sup>4</sup> ) |                                    | 1~5V            |                     | 1~5V                |                     | 1~5V       |          |  |
| 16                               | Analog output<br>adjustment<br>( <sup>3</sup> )               | Output 1                           | Bias adjustment | 0.0%                |                     | 0.0%                |            | 0.0%     |  |
|                                  |                                                               |                                    | Span adjustment | 100.0%              |                     | 100.0%              |            | 100.0%   |  |
|                                  |                                                               | Output 2                           | Bias adjustment | 0.0%                |                     | 0.0%                |            | 0.0%     |  |
|                                  |                                                               |                                    | Span adjustment | 100.0%              |                     | 100.0%              |            | 100.0%   |  |
|                                  |                                                               | Output 3                           | Bias adjustment | 0.0%                |                     | 0.0%                |            | 0.0%     |  |
|                                  |                                                               |                                    | Span adjustment | 100.0%              |                     | 100.0%              |            | 100.0%   |  |
|                                  |                                                               | Output 4                           | Bias adjustment | 0.0%                |                     | 0.0%                |            | 0.0%     |  |
|                                  |                                                               |                                    | Span adjustment | 100.0%              |                     | 100.0%              |            | 100.0%   |  |

Note(<sup>3</sup>) A setting item is not displayed in case there is no corresponding option.

The external operation input constitutes default value with an alarm-output option.

It becomes the next function in case there is no alarm-output option.

Input 1 function: Max. / Min. reset, Input 2 function: Measurement factor change.

Note(<sup>4</sup>) A setting item is not displayed if analog output is except DC0-5V (or DC1-5V) specification,

And analog output insulation product does not display a setting item.

Note(<sup>5</sup>) When the setting of phase line change of an input circuit is changed, it will return to the default value of phase line which all set value changed.

Note(<sup>6</sup>) When phase line change setting of an input circuit is set as 3 $\phi$ 3W (or 1 $\phi$ 2W) and the input voltage setting is changed, the voltage range returns to the default value of the phase line.

(For example: In case of 3 $\phi$ 3W, 6600V at the case of 110V setting, 300V at the case of 220V setting.)

## ② Current input

| No. | Setting item                       |                                          | 3-phase 3-wire                          | Single-phase 3-wire     | Single-phase            |          |     |
|-----|------------------------------------|------------------------------------------|-----------------------------------------|-------------------------|-------------------------|----------|-----|
| 1   | Display combination                | Pattern                                  | Pattern 15                              | Pattern 15              | Pattern 15              |          |     |
|     |                                    | Main monitor                             | A (Y)                                   | A (R)                   | A                       |          |     |
|     |                                    | Sub-monitor (Left)                       | A (R)                                   | A (B)                   | —                       |          |     |
|     |                                    | Sub-monitor (Center)                     | A (B)                                   | A (W)                   | —                       |          |     |
|     |                                    | Sub-monitor (Right)                      | —                                       | —                       | —                       |          |     |
|     |                                    | Bar graph                                | A (Y)                                   | A (R)                   | A                       |          |     |
| 2   | Alarm output (7)                   | Alarm 1                                  | Factor                                  | DA                      | DA                      | DA       |     |
|     |                                    |                                          | Reset form                              | AUTO                    | AUTO                    | AUTO     |     |
|     |                                    |                                          | Contact delay time                      | 0 second                | 0 second                | 0 second |     |
|     |                                    |                                          | Test                                    | —                       | —                       | —        |     |
|     |                                    | Alarm 2                                  | Factor                                  | DA                      | DA                      | DA       |     |
|     |                                    |                                          | Reset form                              | AUTO                    | AUTO                    | AUTO     |     |
|     |                                    |                                          | Contact delay time                      | 0 second                | 0 second                | 0 second |     |
|     |                                    |                                          | Test                                    | —                       | —                       | —        |     |
| 3   | Demand detection                   | Demand current                           | Upper limit value                       | 80.0A                   | 400A                    | 40.0A    |     |
|     |                                    |                                          | Interval                                | 0 second                | 0 second                | 0 second |     |
| 4   | Harmonic detection                 | Current                                  | Distortion-factor upper limit           | OFF                     | OFF                     | OFF      |     |
|     |                                    |                                          | 5th conversion content rate upper limit | OFF                     | OFF                     | OFF      |     |
|     |                                    |                                          | n-th content rate                       | Factor                  | 5th                     | 5th      | 5th |
|     |                                    |                                          |                                         | Upper limit             | OFF                     | OFF      | OFF |
|     |                                    | 5th conversion detection characteristics | Inverse-time-delay mode                 | Inverse-time-delay mode | Inverse-time-delay mode |          |     |
|     |                                    | Average value time limit                 | 0 minute                                | 0 minute                | 0 minute                |          |     |
| 5   | Leakage detection (7)              | Rated sensitivity current                | 0.1A                                    | 0.1A                    | 0.1A                    |          |     |
|     |                                    | Factor switching                         | Io                                      | Io                      | Io                      |          |     |
|     |                                    | Circuit switching                        | 1 phase earthing                        | 1 phase earthing        | 1 phase earthing        |          |     |
|     |                                    | Use ZCF selection                        | Type 0                                  | Type 0                  | Type 0                  |          |     |
| 6   | Backlight                          | Action                                   | AUTO                                    | AUTO                    | AUTO                    |          |     |
|     |                                    | Brightness (10)                          | 3 (Middle)                              | 3 (Middle)              | 3 (Middle)              |          |     |
| 7   | Measurement range                  | Current range                            | 100.0A                                  | 500A                    | 50.0A                   |          |     |
|     |                                    | Current display peculiar sensitivity     | 100.0A                                  | 500A                    | 50.0A                   |          |     |
| 8   | Analog output (7)                  | Output factor 1                          | A (Y)                                   | A (R)                   | A                       |          |     |
|     |                                    | Output factor 2                          | A (R)                                   | A (B)                   | —                       |          |     |
|     |                                    | Output factor 3                          | A (B)                                   | A (W)                   | —                       |          |     |
|     |                                    | Output factor 4                          | —                                       | —                       | —                       |          |     |
|     |                                    | Output peculiar sensitivity              | Current                                 | 100.0%                  | 100.0%                  | 100.0%   |     |
|     |                                    | Low input cut                            | OFF                                     | OFF                     | OFF                     |          |     |
| 9   | External operation input (7)       | Input 1 function                         | Alarm reset                             | Alarm reset             | Alarm reset             |          |     |
|     |                                    | Input 2 function                         | Max./Min. reset                         | Max./Min. reset         | Max./Min. reset         |          |     |
| 10  | Measurement display ON/OFF         | Current                                  | ON                                      | ON                      | ON                      |          |     |
|     |                                    | Harmonic current                         | ON                                      | ON                      | ON                      |          |     |
|     |                                    | Current leakage (7)                      | ON                                      | ON                      | ON                      |          |     |
| 11  | Input circuit                      | Phase line change (9)                    | 3 $\phi$ 3W                             | 1 $\phi$ 3W(R-W-B)      | 1 $\phi$ 2W             |          |     |
| 12  | Measurement                        | Dead band                                | 0.0%                                    | 0.0%                    | 0.0%                    |          |     |
|     |                                    | Tidal current measurement                | General measurement                     | General measurement     | General measurement     |          |     |
| 13  | Analog output specification (7)(8) |                                          | 1~5V                                    | 1~5V                    | 1~5V                    |          |     |
| 14  | Analog output adjustment (7)       | Output 1                                 | Bias adjustment                         | 0.0%                    | 0.0%                    | 0.0%     |     |
|     |                                    |                                          | Span adjustment                         | 100.0%                  | 100.0%                  | 100.0%   |     |
|     |                                    | Output 2                                 | Bias adjustment                         | 0.0%                    | 0.0%                    | 0.0%     |     |
|     |                                    |                                          | Span adjustment                         | 100.0%                  | 100.0%                  | 100.0%   |     |
|     |                                    | Output 3                                 | Bias adjustment                         | 0.0%                    | 0.0%                    | 0.0%     |     |
|     |                                    |                                          | Span adjustment                         | 100.0%                  | 100.0%                  | 100.0%   |     |
|     |                                    | Output 4                                 | Bias adjustment                         | 0.0%                    | 0.0%                    | 0.0%     |     |
|     |                                    |                                          | Span adjustment                         | 100.0%                  | 100.0%                  | 100.0%   |     |

Note(7) A setting item is not displayed in case there is no corresponding option.

The external operation input constitutes default value with an alarm-output option.

It becomes the next function in case there is no alarm-output option.

Input 1 function: Max. / Min. reset, Input 2 function: Measurement factor change.

Note(8) A setting item is not displayed if analog output is except DC0-5V (or DC1-5V) specification,

And analog output insulation product does not display a setting item.

Note(9) When the setting of phase line change of an input circuit is changed, it will return to the default value of phase line which all set value changed.

Note(10) In the case of green backlight, it does not indicate the setting item of brightness.

## ③ Voltage input

| No.                      | Setting item                                                |                                          | 3-phase 3-wire                          |                         | Single-phase 3-wire | Single-phase            |                         |  |
|--------------------------|-------------------------------------------------------------|------------------------------------------|-----------------------------------------|-------------------------|---------------------|-------------------------|-------------------------|--|
|                          |                                                             |                                          | 110V input                              | 220V input              |                     | 110V input              | 220V input              |  |
| 1                        | Display combination                                         | Pattern                                  |                                         | Pattern 16              |                     | Pattern 16              |                         |  |
|                          |                                                             | Main monitor                             |                                         | V (RY)                  |                     | V (RW)                  | V                       |  |
|                          |                                                             | Sub-monitor (Left)                       |                                         | V (YB)                  |                     | V (BW)                  | —                       |  |
|                          |                                                             | Sub-monitor (Center)                     |                                         | V (BR)                  |                     | V (RB)                  | —                       |  |
|                          |                                                             | Sub-monitor (Right)                      |                                         | Hz                      |                     | Hz                      | Hz                      |  |
| Bar graph                |                                                             | V (RY)                                   |                                         | V (RW)                  | V                   |                         |                         |  |
| 2                        | Alarm output <sup>(11)</sup>                                | Alarm 1                                  | Factor                                  |                         | V                   | V                       | V                       |  |
|                          |                                                             |                                          | Reset form                              |                         | AUTO                | AUTO                    | AUTO                    |  |
|                          |                                                             |                                          | Contact delay time                      |                         | 0 second            | 0 second                | 0 second                |  |
|                          |                                                             |                                          | Test                                    |                         | —                   | —                       | —                       |  |
|                          |                                                             | Alarm 2                                  | Factor                                  |                         | V                   | V                       | V                       |  |
|                          |                                                             |                                          | Reset form                              |                         | AUTO                | AUTO                    | AUTO                    |  |
|                          |                                                             |                                          | Contact delay time                      |                         | 0 second            | 0 second                | 0 second                |  |
|                          |                                                             |                                          | Test                                    |                         | —                   | —                       | —                       |  |
| 3                        | Harmonic detection                                          | Voltage                                  | Distortion-factor upper limit           |                         | OFF                 | OFF                     | OFF                     |  |
|                          |                                                             |                                          | 5th conversion content rate upper limit |                         | OFF                 | OFF                     | OFF                     |  |
|                          |                                                             |                                          | n-th content rate                       | Factor                  | 5th                 | 5th                     | 5th                     |  |
|                          |                                                             |                                          | Upper limit                             | OFF                     | OFF                 | OFF                     |                         |  |
|                          |                                                             | 5th conversion detection characteristics |                                         | Inverse-time-delay mode |                     | Inverse-time-delay mode | Inverse-time-delay mode |  |
| Average value time limit |                                                             | 0 minute                                 |                                         | 0 minute                | 0 minute            |                         |                         |  |
| 4                        | Instant measurement detection                               | Voltage upper limit value                |                                         | OFF                     | OFF                 | OFF                     |                         |  |
|                          |                                                             | Voltage lower limit value                |                                         | OFF                     | OFF                 | OFF                     |                         |  |
| 5                        | Leakage detection <sup>(11)</sup>                           | Rated sensitivity current                |                                         | 0.1A                    | 0.1A                | 0.1A                    |                         |  |
|                          |                                                             | Factor switching                         |                                         | Io                      | Io                  | Io                      |                         |  |
|                          |                                                             | Circuit switching                        |                                         | 1 phase earthing        | 1 phase earthing    | 1 phase earthing        |                         |  |
|                          |                                                             | Use ZCT selection                        |                                         | Type 0                  | Type 0              | Type 0                  |                         |  |
| 6                        | Backlight                                                   | Action                                   |                                         | AUTO                    | AUTO                | AUTO                    |                         |  |
|                          |                                                             | Brightness <sup>(15)</sup>               |                                         | 3 (Middle)              | 3 (Middle)          | 3 (Middle)              |                         |  |
| 7                        | Measurement range                                           | Voltage range                            |                                         | 6600V   220V            | 110.0V              | 3300V   220V            |                         |  |
|                          |                                                             | Frequency range                          |                                         | 45.0~65.0Hz             | 45.0~65.0Hz         | 45.0~65.0Hz             |                         |  |
| 8                        | Analog output <sup>(11)</sup>                               | Output factor 1                          |                                         | V (RY)                  | V (RW)              | V                       |                         |  |
|                          |                                                             | Output factor 2                          |                                         | V (YB)                  | V (BW)              | —                       |                         |  |
|                          |                                                             | Output factor 3                          |                                         | V (BR)                  | V (RB)              | —                       |                         |  |
|                          |                                                             | Output factor 4                          |                                         | Hz                      | Hz                  | Hz                      |                         |  |
|                          |                                                             | Low input cut                            |                                         | OFF                     | OFF                 | OFF                     |                         |  |
| 9                        | External operation input <sup>(11)</sup>                    | Input 1 function                         |                                         | Alarm reset             | Alarm reset         | Alarm reset             |                         |  |
|                          |                                                             | Input 2 function                         |                                         | Max./Min. reset         | Max./Min. reset     | Max./Min. reset         |                         |  |
| 10                       | Measurement display ON/OFF                                  | Voltage                                  |                                         | ON                      | ON                  | ON                      |                         |  |
|                          |                                                             | Frequency                                |                                         | ON                      | ON                  | ON                      |                         |  |
|                          |                                                             | Harmonic voltage                         |                                         | ON                      | ON                  | ON                      |                         |  |
|                          |                                                             | Current leakage <sup>(11)</sup>          |                                         | ON                      | ON                  | ON                      |                         |  |
| 11                       | Input circuit                                               | Phase line change <sup>(13)</sup>        |                                         | 3 $\phi$ 3W             | 1 $\phi$ 3W (R-W-B) | 1 $\phi$ 2W             |                         |  |
|                          |                                                             | Input voltage <sup>(14)</sup>            |                                         | 110V   220V             | 300V                | 110V   220V             |                         |  |
| 12                       | Measurement                                                 | Dead band                                |                                         | 0.0%                    | 0.0%                | 0.0%                    |                         |  |
|                          |                                                             | Tidal current measurement                |                                         | General measurement     | General measurement | General measurement     |                         |  |
| 15                       | Analog output specification <sup>(11)</sup> <sup>(12)</sup> |                                          | 1~5V                                    | 1~5V                    | 1~5V                |                         |                         |  |
| 16                       | Analog output adjustment <sup>(11)</sup>                    | Output 1                                 | Bias adjustment                         |                         | 0.0%                | 0.0%                    | 0.0%                    |  |
|                          |                                                             |                                          | Span adjustment                         |                         | 100.0%              | 100.0%                  | 100.0%                  |  |
|                          |                                                             | Output 2                                 | Bias adjustment                         |                         | 0.0%                | 0.0%                    | 0.0%                    |  |
|                          |                                                             |                                          | Span adjustment                         |                         | 100.0%              | 100.0%                  | 100.0%                  |  |
|                          |                                                             | Output 3                                 | Bias adjustment                         |                         | 0.0%                | 0.0%                    | 0.0%                    |  |
|                          |                                                             |                                          | Span adjustment                         |                         | 100.0%              | 100.0%                  | 100.0%                  |  |
|                          |                                                             | Output 4                                 | Bias adjustment                         |                         | 0.0%                | 0.0%                    | 0.0%                    |  |
|                          |                                                             |                                          | Span adjustment                         |                         | 100.0%              | 100.0%                  | 100.0%                  |  |

Note<sup>(11)</sup> A setting item is not displayed in case there is no corresponding option.

The external operation input constitutes default value with an alarm-output option.

It becomes the next function in case there is no alarm-output option. Input 1 function: Max. / Min. reset, Input 2 function: Measurement factor change.

Note<sup>(12)</sup> A setting item is not displayed if analog output is except DC0-5V (or DC1-5V) specification,

And analog output insulation product does not display a setting item.

Note<sup>(13)</sup> When the setting of phase line change of an input circuit is changed, it will return to the default value of phase line which all set value changed.

Note<sup>(14)</sup> When phase line change setting of an input circuit is set as 3 $\phi$ 3W (or 1 $\phi$ 2W) and the input voltage setting is changed, the voltage range returns to the default value of the phase line.

(For example: In case of 3 $\phi$ 3W, 6600V at the case of 110V setting, 300V at the case of 220V setting.)

Note<sup>(15)</sup> In the case of green backlight, it does not indicate the setting item of brightness.

## 6. Operation

Be careful with the following cautions during use.

- Use the input within the rated range. Be careful since negligence of this caution may cause troubles of the unit.
- There is a function to hold the maximum value and the minimum value with a measurement factor in this product. A blackout is guaranteed and this value isn't also cleared by a power supply reset. However, the minimum value may be updated in case input is not applied to a power up. For this reason, in order to make the past minimum value hold by powering on, please apply input within 1 second after switching on a power supply.

- The maximum value, a minimum value measurement factor

| Measurement factor                                                                                           | Maximum value measurement | Minimum value measurement |
|--------------------------------------------------------------------------------------------------------------|---------------------------|---------------------------|
| Voltage, Current, Demand current, Active power, Demand active power, Reactive power, Power factor, Frequency | ○                         | ○                         |
| Current leakage, Harmonic (Distortion factor, Effective value, Content)                                      | ○                         | ×                         |

|                                                                                                     |                                                                                                                                                                                                                                                                                                                                                                                                                  |
|-----------------------------------------------------------------------------------------------------|------------------------------------------------------------------------------------------------------------------------------------------------------------------------------------------------------------------------------------------------------------------------------------------------------------------------------------------------------------------------------------------------------------------|
| <br><b>CAUTION</b> | <ul style="list-style-type: none"> <li>● Be careful not to touch any terminal when power is applied to the unit.</li> <li>● Don't disassemble or modify this unit without any previous permission of our company, otherwise the warranty does not apply to the unit any more. Also, modifications may cause troubles, a fire, or other accidents. For specifications change, etc., please contact us.</li> </ul> |
|-----------------------------------------------------------------------------------------------------|------------------------------------------------------------------------------------------------------------------------------------------------------------------------------------------------------------------------------------------------------------------------------------------------------------------------------------------------------------------------------------------------------------------|

## 7. Maintenance and check

- ① Wipe off the surface of the unit with a dry soft cloth. The liquid crystal display (LCD) may light during cleaning on the LCD face. However, this phenomenon is caused by the static electricity that may be produced in the filter, and it does not show any trouble. Leave the unit as it is for a while, and the display goes out due to natural discharge. Don't press the LCD face strongly, otherwise it may be broken.  
When the filter has been pressed, it may touch the LCD face to stain the LCD face. However, this phenomenon does not show any trouble, but it is caused by a change of the ambient environment or the like.  
The LCD face may be restored to its original condition after a while during the use as it is.
- ② Check the following items.
  - ◎ Check the unit for damage in appearance.
  - ◎ Check if indications conform to the inputs.
  - ◎ Check if the unit is mounted normally without any loose connections of the terminal board after turning off the power supply.

If a question has arisen or if the unit seems to be defective, please contact us.

## 8. Other precautions

- Wipe off dirt on the surface with dry cloth softly. Keep in mind that strong rubbing of nameplate leads to character disappearance. Organic solvent is not appropriate for cleaning.
- Neither mercury parts nor the nickel-cadmium battery is being used for this product.
- This product is disposed as an industrial waste (non-inflammable).

## 9. Warranty

- Warranty period

It is for one year after product delivery.

- Warranty scope

In the state of the normal use of product-specification within the range according to this instruction manual, the trouble within the warranty period performs exchange or repair gratuitously.

However, the shipping expenses and the packing cost in the case of shipping obtain as payment on a customer.

And, if it corresponds to the next, it does not warrant.

- (1) If it breaks down when converted or repaired except our company.
- (2) If it breaks down by use outside the specification range.
- (3) If the cause of trouble is based on cause other than this product.
- (4) Transportation, movement, damage by falling, and trouble.
- (5) A natural disaster, disaster, etc., if it is the trouble which is irresponsible for a payment side (our company or distributing agent).

Only a product simplex is applied with a warranty. We cannot bear the responsibility such as the damage and the loss that occurred by the use of this product and trouble or the loss of profits.

And, a warranty is effective only in Japan.



## Content

|                                                              |    |
|--------------------------------------------------------------|----|
| 1. Product outline .....                                     | 9  |
| 1.1 Usage of product .....                                   | 9  |
| 1.2 Features of product .....                                | 9  |
| 2. The name and function of each part .....                  | 10 |
| 3. Preparation                                               |    |
| 3.1 Installation .....                                       | 10 |
| 3.2 Connections .....                                        | 12 |
| 4. Operation .....                                           | 17 |
| 4.1 The screen change and function by switch operation ..... | 18 |
| 4.2 The kind of display .....                                | 19 |
| 4.2.1 Measurement display .....                              | 19 |
| 4.2.2 Alarm detection display .....                          | 22 |
| 4.2.3 Setting display .....                                  | 24 |
| 4.3 Operation .....                                          | 25 |
| 4.3.1 The main monitor display-element change .....          | 25 |
| 4.3.2 Phase (line) display change .....                      | 25 |
| 4.3.3 Harmonic measurement display change .....              | 26 |
| 4.3.4 Watt-hour enlarged display .....                       | 26 |
| 4.3.5 Setting value check .....                              | 27 |
| 4.3.6 Setting mode .....                                     | 28 |
| 4.3.7 Reset .....                                            | 29 |
| 5. Setting                                                   |    |
| 5.1 Function table .....                                     | 32 |
| 5.2 Setting table .....                                      | 37 |
| 5.3 Setting in detail explanation .....                      | 46 |
| 5.3.1 Setting mode 1 .....                                   | 46 |
| 5.3.2 Setting mode 2 .....                                   | 58 |
| 5.3.3 Setting mode 3 .....                                   | 65 |
| 6. Specification                                             |    |
| 6.1 Specification and intrinsic error .....                  | 69 |
| 6.2 Specification, Performance. ....                         | 73 |
| 6.3 Option .....                                             | 75 |
| 7. Maintenance and check                                     |    |
| 7.1 Trouble shooting .....                                   | 77 |
| 7.2 Check .....                                              | 77 |
| 7.3 Maintenance .....                                        | 77 |
| 7.4 Test .....                                               | 78 |
| 7.5 Storage .....                                            | 78 |
| 7.6 Countermeasures against troubles .....                   | 78 |

Appendix table 1 to 3

## 1. Product outline

### 1.1 Usage of product

This single unit can measure and monitor demand-current  $\times 3$ , voltage  $\times 3$ , current  $\times 3$ , demand active power, active-power, reactive-power, power-factor, frequency, watt-hour, var-hour, harmonic(voltage, current) and current leakage.

From a low tension circuit to a high tension circuit, it is adapted for various usages, such as a measurement monitor of a power-receiving circuit, an energy conservation power monitor, a demand current measurement monitor, and a harmonic monitor, a leakage monitor.

The intensive monitor united with the system is made in an addendum of analog output and a pulse output.

### 1.2 Features of product

- High-performance products which collected the function of the power line multi-meter (QLC-110L, DLC-110L, HLC-110L, LLC-110L) of our company.
- A 3-phase 3-wire, single-phase, and single-phase 3-wire common type can be prepared. It's possible to share stock.
- Bar graph 1 measurement and digital 4 measurement are displayed simultaneously.
- Analog output 4 circuit and contact-output 2 circuit can be taken out. (Option)  
A contact output can be selected from a pulse output, an alarm output, and a CPU error output. (Please designate it at an order.) And, An output factor can be selected by setting.
- Two external operation inputs are possible. (Option) And, selection of reset input and a display change input is possible at setting.
- Power supply is AC85~264V, DC80~143V (for both AC and DC uses).
- The mounting method of this unit is compatible with the mounting method of conventional 110 square mechanical meter. This unit is mounted at 2 diagonal points.
- Integrated value of Wh and varh can indicate expansion to 3rd digit below the decimal point.
- Analog output is with a lower limit limiter.
- A tidal current measurement (output 2 quadrant) change is possible for var and  $\cos\phi$ .
- Current-leakage measurement corresponds to both  $I_o$  and  $I_{gr}$ .
- A backlight function is equipped. Selection of backlight-on, backlight-off, and auto backlight-off and setting of brightness (only white backlight) are possible. Automatic turning off the lights at the time of non-operation can be established. LED: Green or White (appoints by order).
- LCD can be chosen from 2 kinds, the type to see from the top and the type to see from the bottom. (Please designate it at an order.)
- The product with analog output can be selected from between analog output insulation type and the analog output non-insulation type. (Please specify at the time of an order.)

2. The name and function of each part

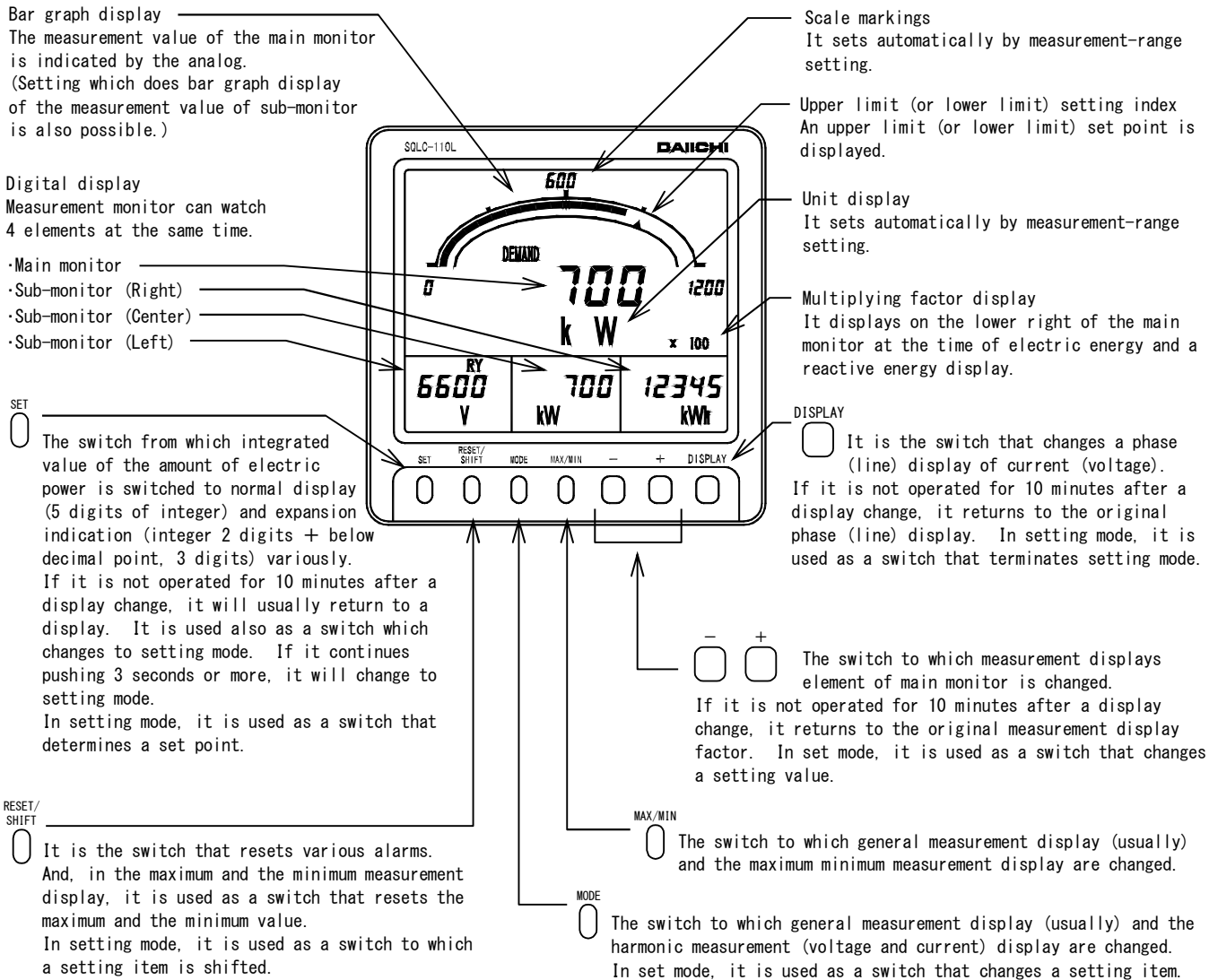

3. Preparation

3.1 Installation

Mount the unit by the attached M5 nuts to a panel of thinner than 10mm, referring to the following external dimensions drawing and panel cutout. Fasten these nuts with tightening torque 2.75~3.82N·m.

● Dimension diagram

(1) Multi-meter

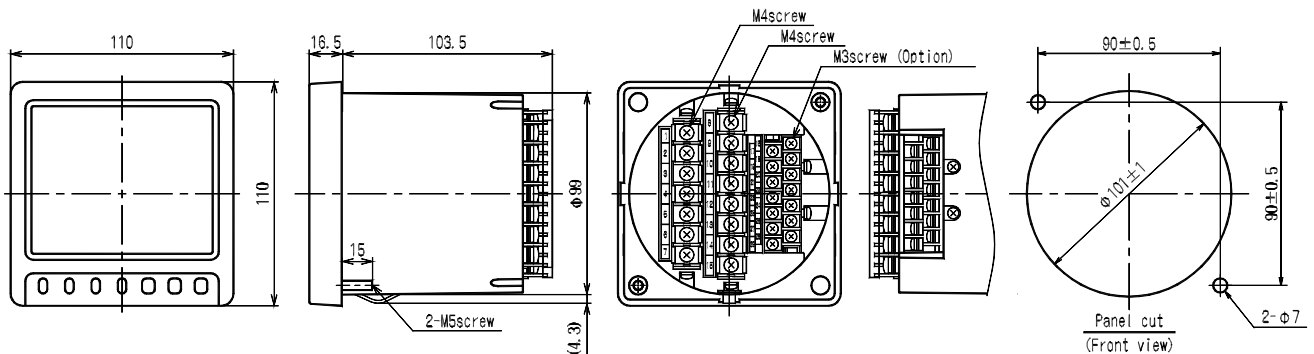

(2) Correspondence ZCT (Our company recommendation) ZCT is not attached with leakage measurement.

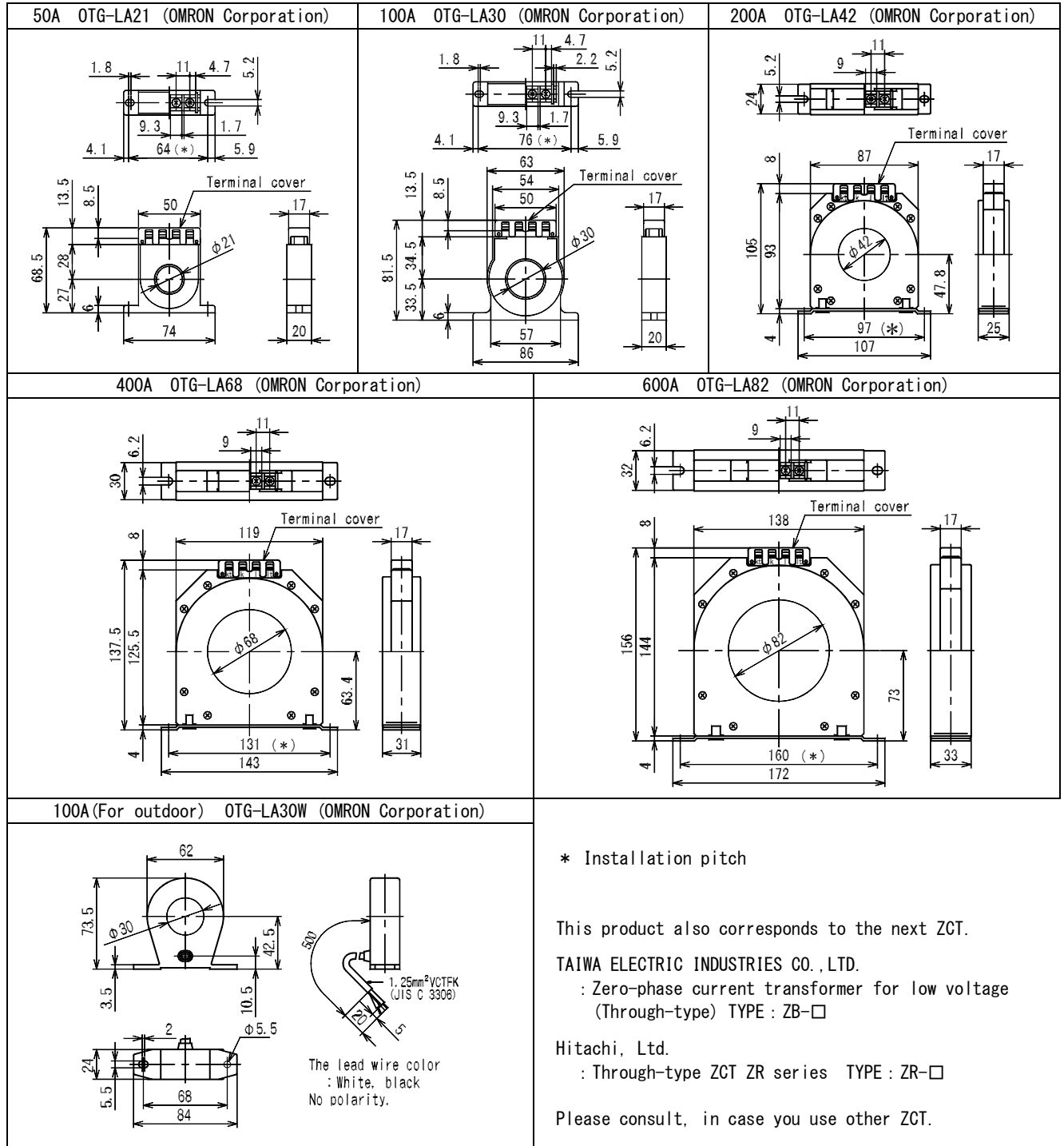

● Caution on handling  
Mount the LCD to obtain an optimum angle, since the contrast changes according to the monitoring angle.

(1) For upper case installation

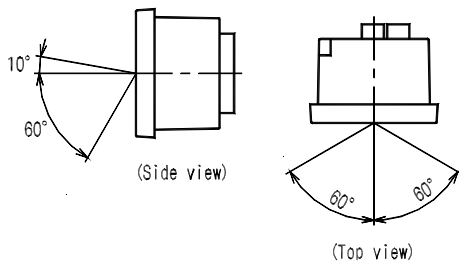

(2) For lower case installation

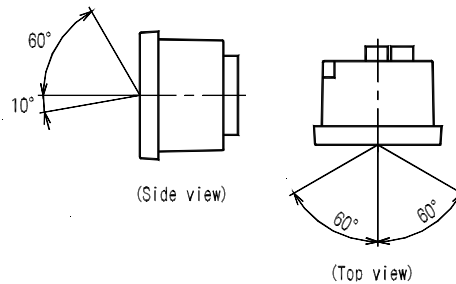

● Installation

- (1) A product is put in a cut hole of a panel from a front. A body is inserted until it exceeds retaining stopper of the lower base.
- (2) Please fix a product certainly with attached M5 flange nut for installation. Please give a tightening torque as 2.75 to 3.82N·m.

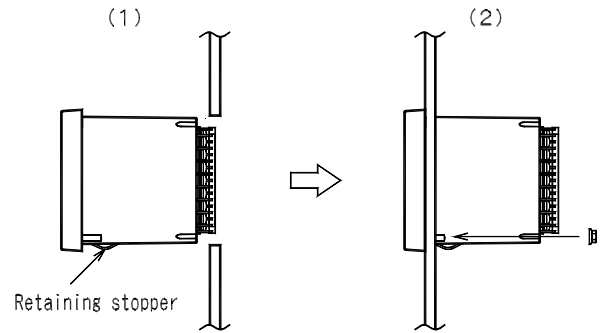

3.2 Connections

Please perform connection after referring to the following wiring diagram.

● Connection drawing (19)

(1) 1φ2W

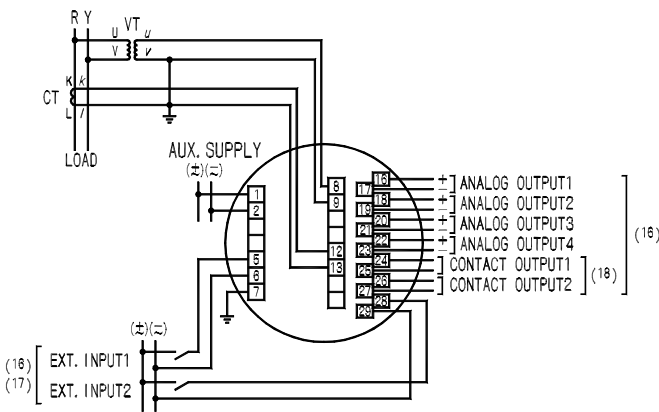

(2) 1φ3W

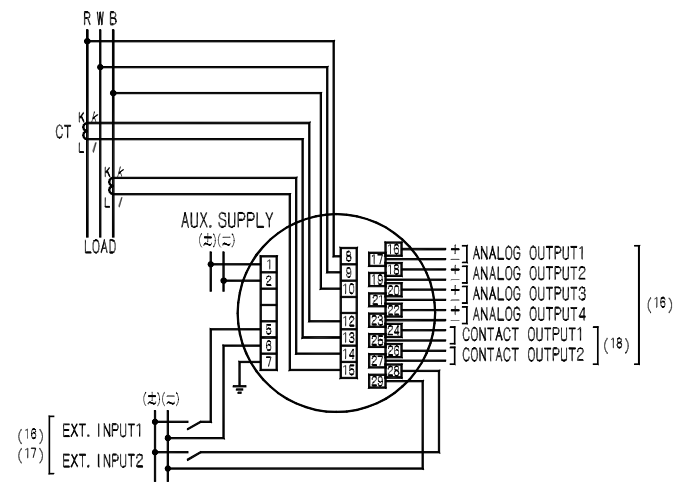

(3) 3φ3W(2VT, 2CT)

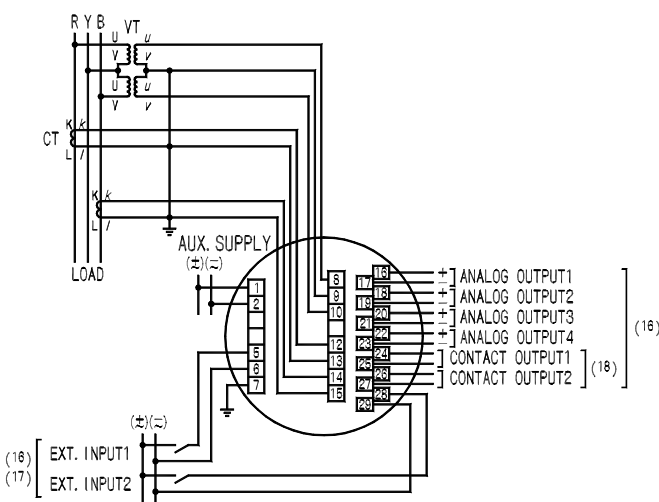

(4) 3φ3W(2VT, 3CT)

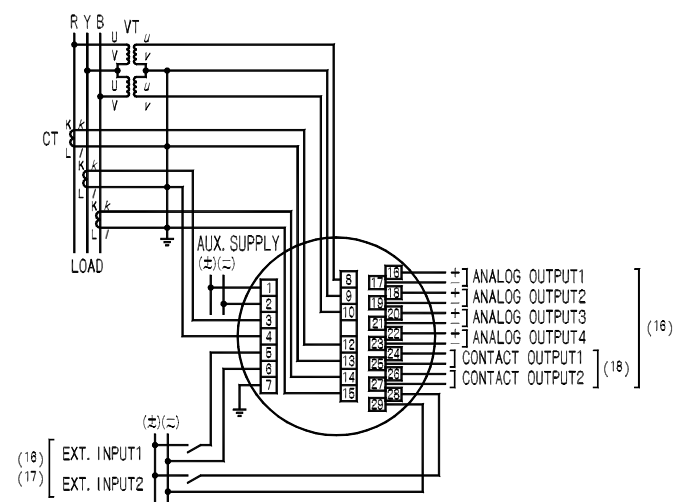

(5) Current input 3φ3W(2CT)

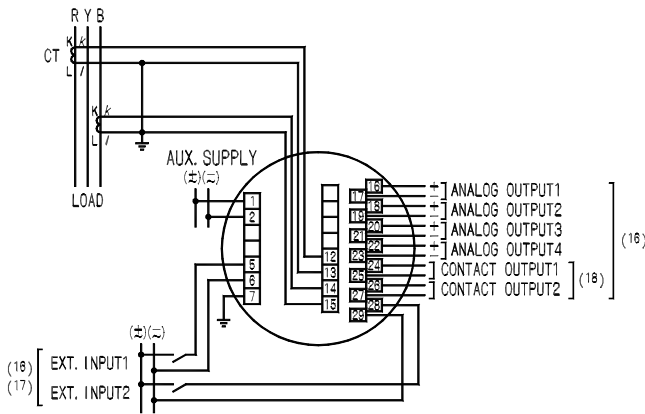

(6) Current input 3φ3W(3CT)

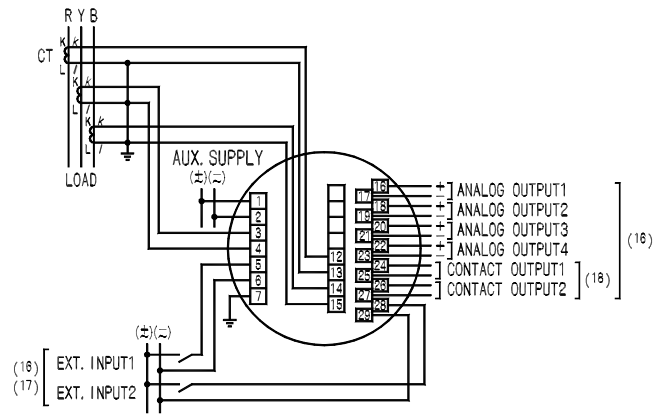

(7) Current input 1φ3W

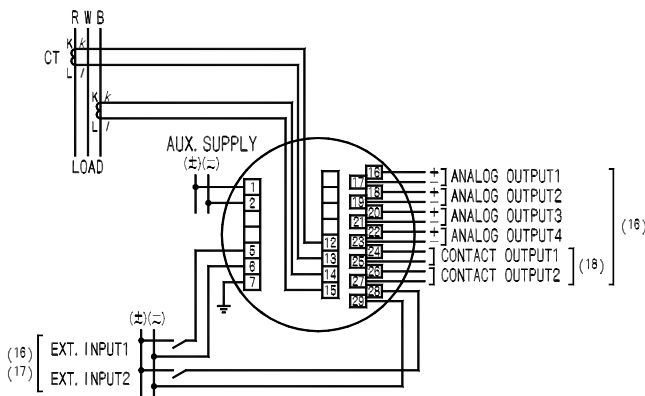

(8) Current input 1φ2W

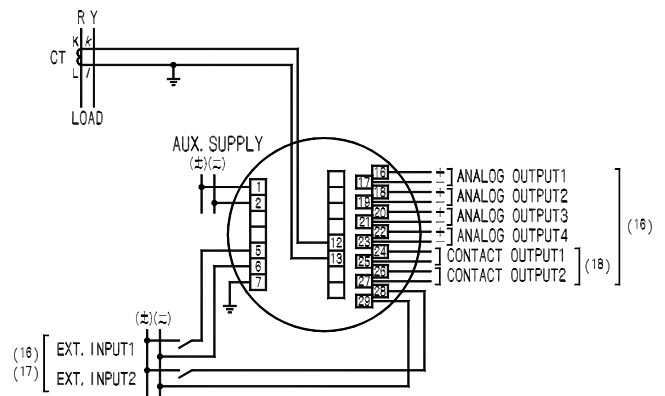

(9) Voltage input 3φ3W

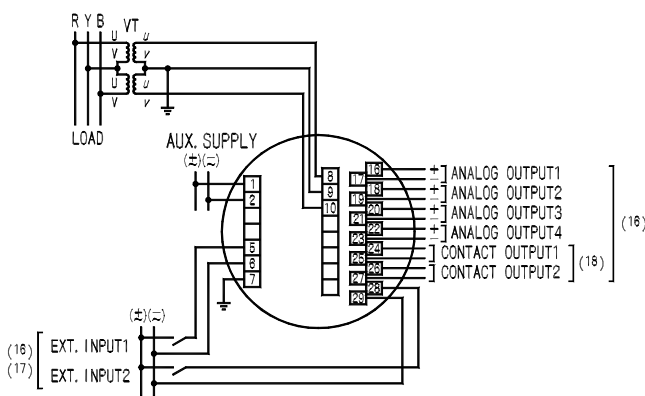

(10) Voltage input 1φ3W

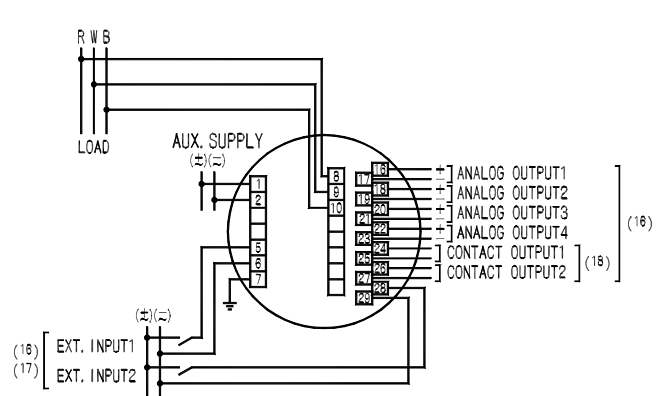

(11) Voltage input 1φ2W

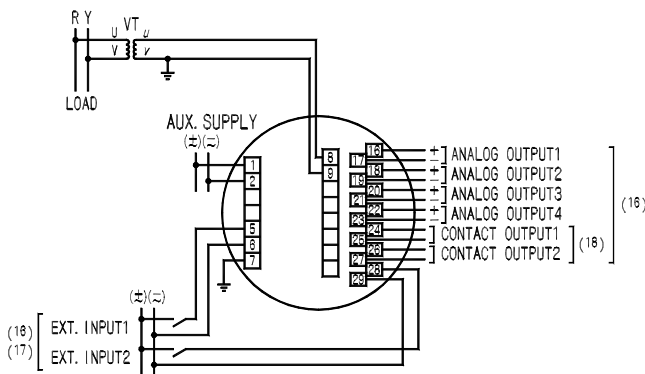

Note<sup>(16)</sup> Analog output, contact output, external operation input is an option.

Note<sup>(17)</sup> Can change to external reset function or external display change function by setting.

Note<sup>(18)</sup> Can choose the contact output among the pulse output, the alarm output, the CPU error output. (Designation)

- Combination of contact output

|                 | Contact output 1 | Contact output 2 |
|-----------------|------------------|------------------|
| Pulse+Alarm     | Pulse output     | Alarm output     |
| Alarm×2         | Alarm output 1   | Alarm output 2   |
| Pulse×2         | Pulse output 1   | Pulse output 2   |
| Pulse+CPU error | Pulse output     | CPU error output |
| Alarm+CPU error | Alarm output     | CPU error output |

Note<sup>(19)</sup> In case of low-voltage circuit, secondary side earthing of VT and CT is unnecessary. And, VT is unnecessary in case it used 110V or direct 220V.

● Schematics in the leakage monitor of low-voltage circuit (23) (25)

(1) 1φ2W (W-phase earth)

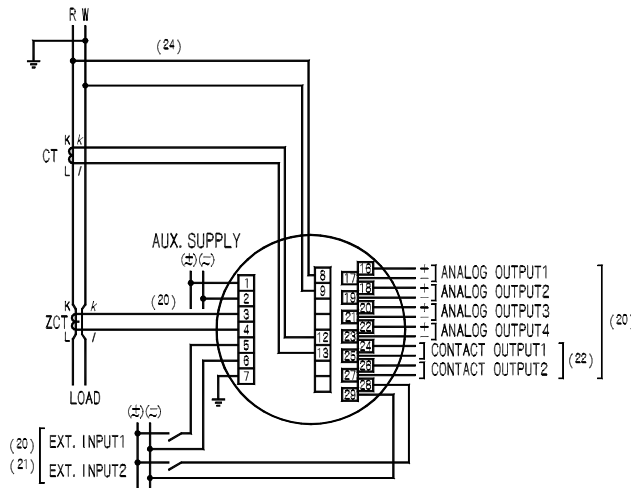

(2) 1φ3W (W-phase earth)

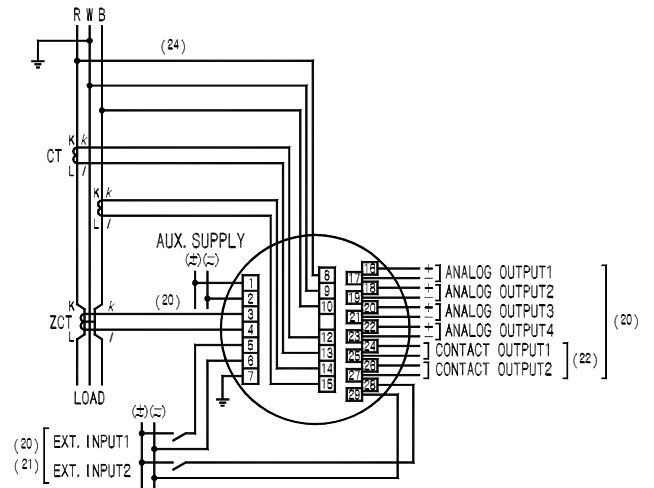

(3) 3φ3W (Y-phase earth)

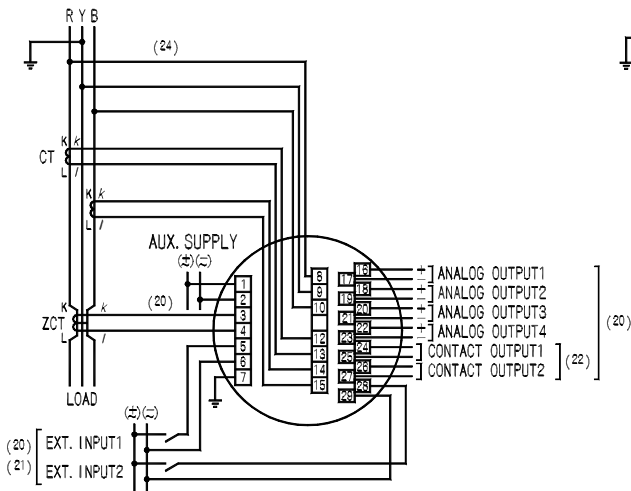

(4) 3φ3W (No earth)

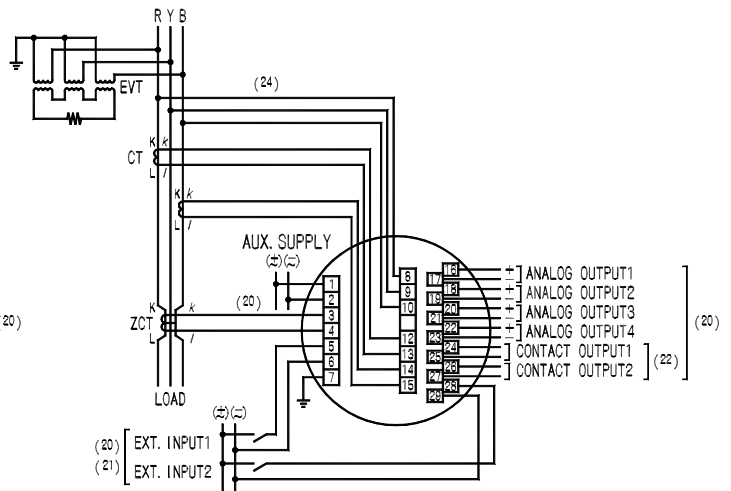

Note<sup>(20)</sup> Analog output, contact output, external operation input is an option. Zero-phase current input product will be only with leakage current measurement.

Note<sup>(21)</sup> Can change to external reset function or external display change function by setting.

Note<sup>(22)</sup> Can choose the contact output among the pulse output, the alarm output, the CPU error output. (Designation)  
 • Combination of contact output

|                 | Contact output 1 | Contact output 2 |
|-----------------|------------------|------------------|
| Pulse+Alarm     | Pulse output     | Alarm output     |
| Alarm×2         | Alarm output 1   | Alarm output 2   |
| Pulse×2         | Pulse output 1   | Pulse output 2   |
| Pulse+CPU error | Pulse output     | CPU error output |
| Alarm+CPU error | Alarm output     | CPU error output |

Note<sup>(23)</sup> In case of low-voltage circuit, secondary side earthing of VT and CT is unnecessary. And, VT is unnecessary in case it used 110V or direct 220V.

Note<sup>(24)</sup> Voltage input is needed at the time of Igr measurement in a short circuit electric current.

Note<sup>(25)</sup> A voltage input and a leakage input are not insulated. Please use it combining ZCT.

- In case of installing ZCT to ground wire by leakage monitor.

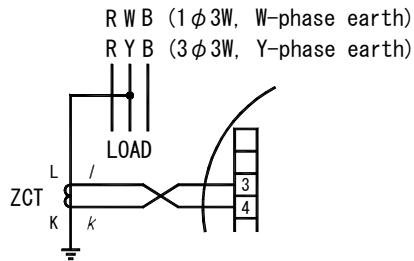

<Caution> When doing  $I_{gr}$  measurement by a leakage monitor, please be careful about polarity of ZCT.

- Caution on connection

- (1) Mount the terminal cover without fail for safety after the end of connections.
- (2) Separate the input wiring and output wiring from each other without fail, and take a preventive measure against malfunction due to external noises.
- (3) Connect the grounding terminal E (No. 7 terminal) to the ground without fail for enhancing the shield effect. Keep the grounding resistance between the grounding terminal and the ground to be lower than  $100\Omega$ .
- (4) Keep a distance of more than 30cm between this unit and the circuit breaker as well as between this unit and the relay contact signal line.
- (5) No protection is necessary for this unit even if the transmission line may be affected by an induced lightning surge or the like when transmitting an analog output to the receiver. Mount an about 500V arrester or the like between the line surge protector and the ground as well as between the transmission line and the ground on the receiver side for the purpose of protecting the devices on the receiver side.
- (6) It is recommended to mount a surge killer outside when connecting an inductive load to the pulse output and alarm output. If no surge killer is mounted, the contact life may shorten.
- (7) Please do not earth the output terminal of ZCT.
- (8) Please shorten wiring for this product from secondary of ZCT as much as possible. And, in case secondary wiring becomes close to other large current circuits, please use shielding wire.
- (9) In case it measures a leakage current  $I_{gr}$ , it is necessary to measure correctly the phase angle of a voltage input and a zero phase-current input. Wiring of ZCT (primary, secondary) and wiring for this product should check schematics.



● The distinction method of the primary side polarity of ZCT

(1) Product of OMRON Corporation

The direction (near side) which can read correctly the character of the name plate currently stuck on ZCT is "K".

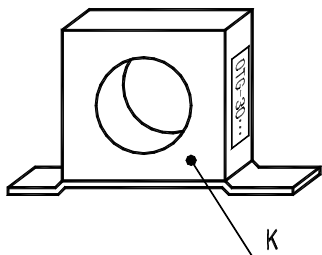

(2) Product of TAIWA ELECTRIC INDUSTRIES CO.,LTD.

① ZB-30M, ZB-58M

A side with "k" and "l" of the terminal for secondary wiring connection is "L".

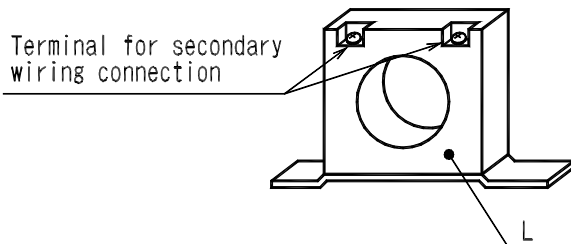

② ZB-70M

The "検" mark side of ZCT is "L".

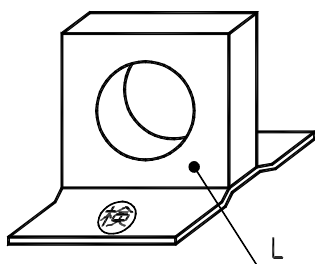

③ ZB-90M

It is printed by ZCT.

(3) Product of Hitachi, Ltd.

① ZR-30B, ZR-58B

A side with "k" and "l" of the terminal for secondary wiring connection is "L".

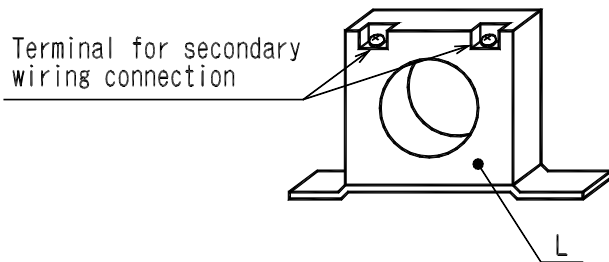

② ZR-65, ZR-80

The name plate side of ZCT is "K".

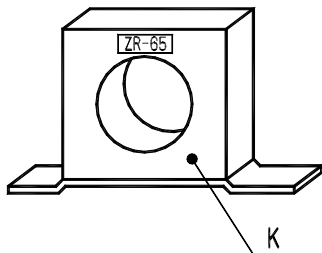

4. Operation

● The function of switch

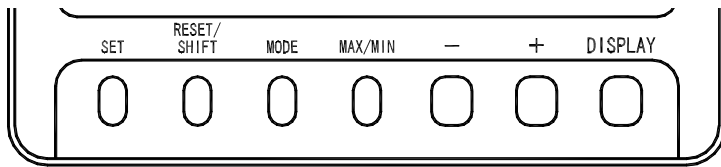

| Switch      | Function                                                                                                                                                                                                                                      |
|-------------|-----------------------------------------------------------------------------------------------------------------------------------------------------------------------------------------------------------------------------------------------|
| SET         | The integrated value of electric energy is changed to the usual display and an enlarged display. If it continues pushing 3 seconds or more, it will change to setting mode. In setting mode, it is used for the determination of a set point. |
| RESET/SHIFT | Various kinds of alarms are reset. The maximum value and the minimum value are reset in the maximum minimum measurement display. In setting mode, it is used for movement of a setting item.                                                  |
| MODE        | The usual general measurement display and harmonic measurement (voltage, current) display are changed. In setting mode, it is used for the change of a setting item.                                                                          |
| MAX/MIN     | The usual measurement display and maximum value or minimum value display are changed.                                                                                                                                                         |
| +, -        | The measurement display element of the main monitor is changed. In setting mode, it is used for change of a set point.                                                                                                                        |
| DISPLAY     | A phase (between lines) display of current (voltage) is changed. It is used in case it terminates setting mode. And, it is used in case it returns the display combination of a measurement factor.                                           |

● Convenient functions

- (1) In case a measurement change or a phase change is performed and the original screen composition is not clear anymore, **DISPLAY** is pushed for more than 3 seconds or it's no-operation for 10 minutes and returns to original screen structure.
- (2) Even if it stops operation with setting mode, it returns to the display mode in 10 minutes.

● 7 segment displays

This product shows the guidance in various setting using 7 segment displays besides a display of a measurement value. A digital readout and 7 segment displays corresponding to each alphabet are shown in the following.

| A    | B(b) | C | D(d) | E    | F | G    | H    | I | J               | K               | L    | M |
|------|------|---|------|------|---|------|------|---|-----------------|-----------------|------|---|
| A    | b    | C | d    | E    | F | G    | H    | I | Non-dis<br>play | Non-dis<br>play | L    | M |
| N(n) | O(o) | P | Q(q) | R(r) | S | T(t) | U(u) | V | W               | X               | Y(y) | Z |
| n    | o    | P | q    | r    | S | t    | u    | v | w               | Non-dis<br>play | y    | z |
| 0    | 1    | 2 | 3    | 4    | 5 | 6    | 7    | 8 | 9               |                 |      |   |
| 0    | 1    | 2 | 3    | 4    | 5 | 6    | 7    | 8 | 9               |                 |      |   |

4.1 The screen change and function by switch operation

This product changes various screens by switch operation. Here, the change step of the screen by switch operation is explained.

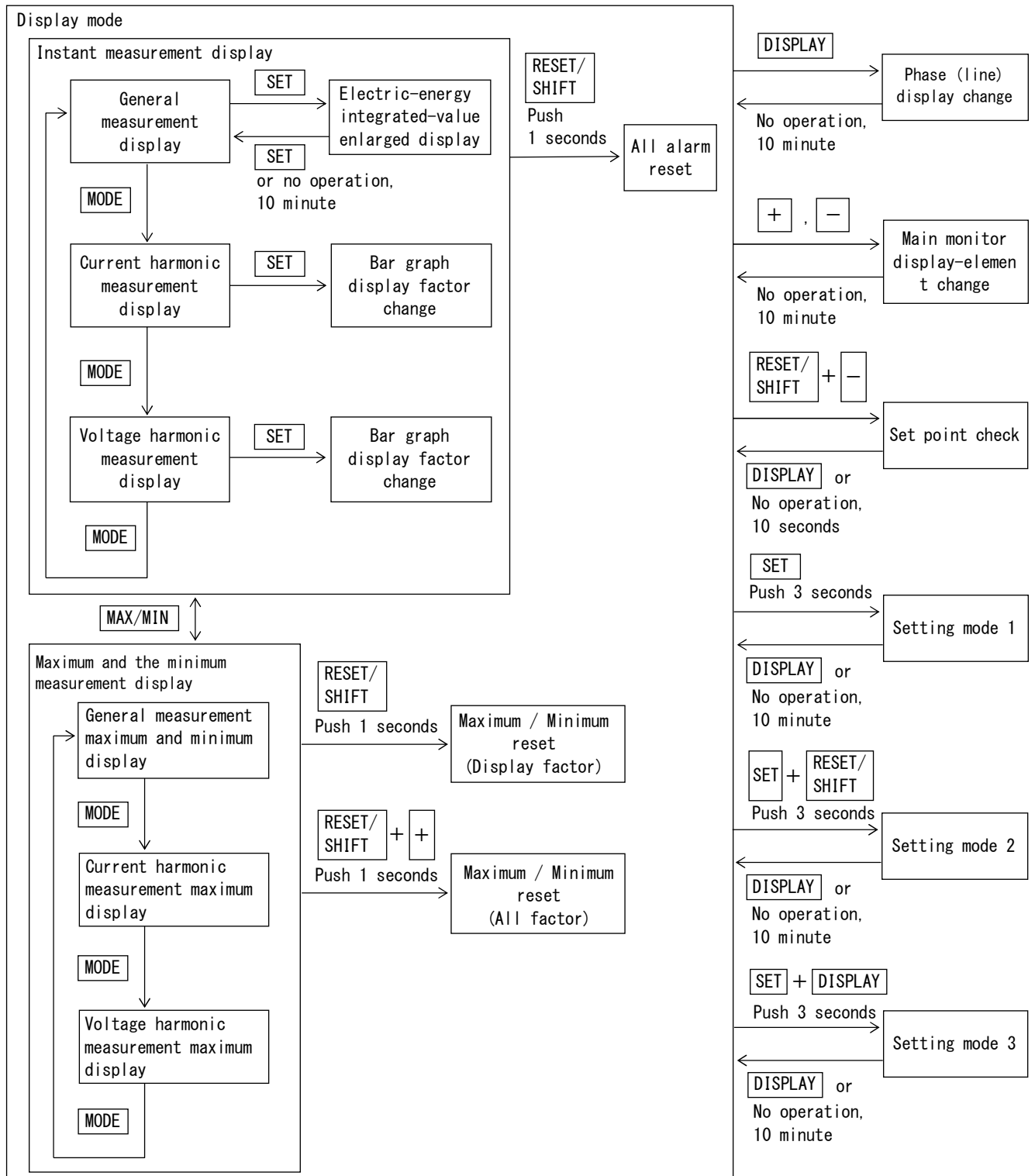

4.2 The kind of display

4.2.1 Measurement display

A measurement value display has the three following types of displays.

The change of the measurement display element of the main monitor by switch operation and the change of the phase / line display of current / voltage is possible (temporarily).

In a general measurement display, if switch operation is not performed for 10 minutes after changing a display element, it returns to the original measurement display element automatically.

① General measurement display

Measurement factors, such as current, voltage, and active power, are displayed.

The measurement value of four factors is displayed at the maximum.

Setting which always displays a measurement factor is possible. And, it is possible to change to a display of the maximum value and the minimum value, about the measurement factor which performs holding of the maximum value and the minimum value by switch operation.

These maximum values and the minimum value are reset by switch operation (it updates to the instantaneous value at the time).

In addition, as for the maximum value and the minimum value, power-supply reset is not cleared either. And, this display is held by even after 10 minutes of switch non-operation.

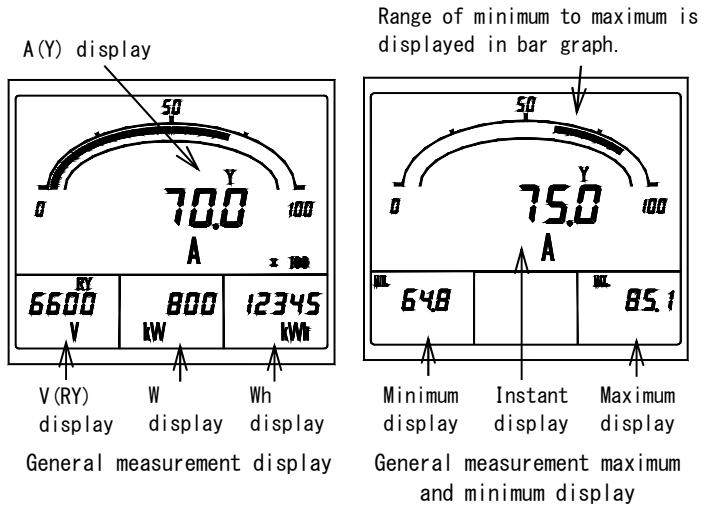

• The example of a measurement display of each measurement factor (Main monitor) ... Harmonic measurement is excluded.

| Measurement factor          | Example of display | Note              | Measurement factor             | Example of display | Note                |
|-----------------------------|--------------------|-------------------|--------------------------------|--------------------|---------------------|
| Voltage                     |                    |                   | Current                        |                    |                     |
| Current leakage             |                    | "LEAK" is display | Demand current                 |                    | "DEMAND" is display |
| Watt-hour (Power receiving) |                    |                   | Watt-hour (Power transmission) |                    | "-" is display      |
| Active power                |                    |                   | Demand active power            |                    | "DEMAND" is display |

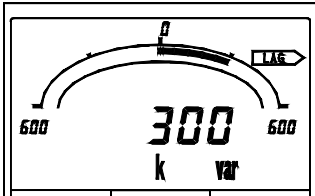
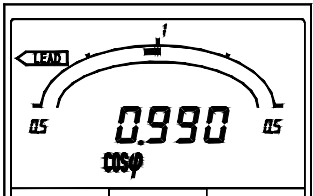
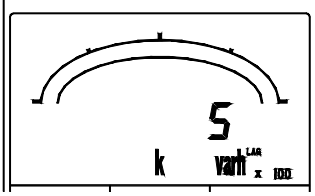
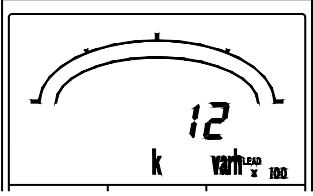
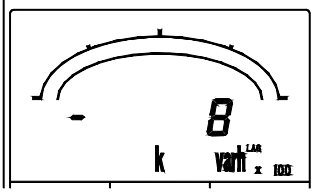
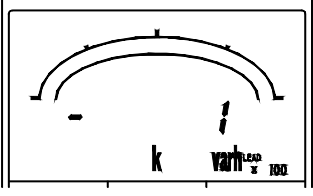
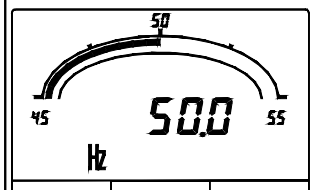
| Measurement factor                    | Example of display                                                                 | Note                         | Measurement factor                     | Example of display                                                                  | Note                         |
|---------------------------------------|------------------------------------------------------------------------------------|------------------------------|----------------------------------------|-------------------------------------------------------------------------------------|------------------------------|
| Reactive power                        |   | LAG<br>or<br>LEAD<br>display | Power factor                           |  | LAG<br>or<br>LEAD<br>display |
| var-hour<br>(Power receiving, LAG)    |   | “LAG” display                | var-hour<br>(Power receiving, LEAD)    |  | “LEAD” display               |
| var-hour<br>(Power transmission, LAG) |   | “LAG” and “-” display        | var-hour<br>(Power transmission, LEAD) |  | “LEAD” and “-” display       |
| Frequency                             |  |                              |                                        |                                                                                     |                              |

• About a current-leakage measurement display

The current leakage of this product can select a factor from the next two types.

① The system by which  $I_0$  where an electric current for the capacity by a earth capacitance ( $I_c$ ) and an electric current for the resistance by insulation degradation ( $I_{gr}$ ) are synthesis is measured.

② The method which measures only the resistance part current ( $I_{gr}$ ) by insulation degradation etc.

By the  $I_{gr}$  method, a current leakage is calculated from a voltage input and a zero phase-current input. In case of 3-phase 3-wire (1-phase earthing), in the range whose phase angle (leading-phase angle of the zero-phase current by reference voltage) of these inputs is  $150\sim 350^\circ$ , it will become the outside of a measuring range and a measurement display of a zero-phase current will be “----”.

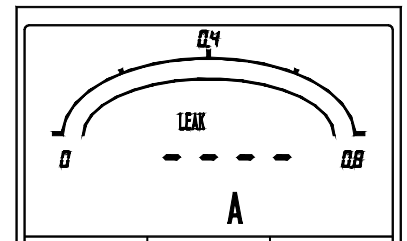

The measurement display besides an  $I_{gr}$  measuring range

② Current harmonic measurement display

It is a measurement factor display of the distortion factor of current, relative harmonic content, harmonic effective value, etc. The measurement value of three factors is displayed at the maximum.

About sub-monitor (center) and sub-monitor (right), it is possible to change to the factor that always indicates by measurement. And, it is possible to change to a display of the maximum value by switch operation.

These maximum values can be reset by switch operation (it updates to the instantaneous value at the time).

In addition, as for the maximum value, even power-supply reset is not cleared. And, a display is held, even after elapsing for 10 minutes without operating a switch.

Measurement display element)

Main monitor : Distortion factor

Sub-monitor (Left) : 5th conversion or harmonic order (n)

Sub-monitor (Center) : Harmonic 5th conversion content or harmonic nth content (n=3, 4, 5, 7, 9, 11, 13, 15)

Sub-monitor (Right) : Fundamental-wave effective value, 5th harmonic conversion effective value or harmonic nth effective value (n=3, 4, 5, 7, 9, 11, 13, 15)

③ Voltage harmonic measurement display

It is a measurement factor display of the distortion factor of voltage, relative harmonic content, harmonic effective value, etc. About a function, it is the same as a current harmonic measurement display.

Distortion-factor display      Effective-value display

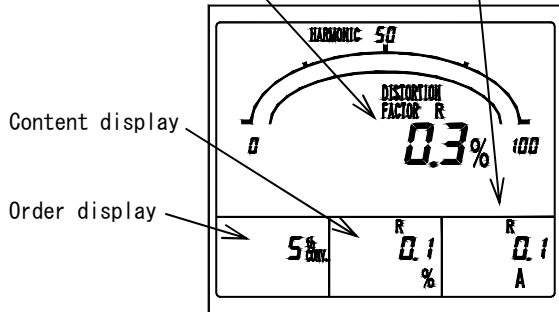

Current harmonic measurement display.

Distortion-factor maximum display      Effective-value maximum display

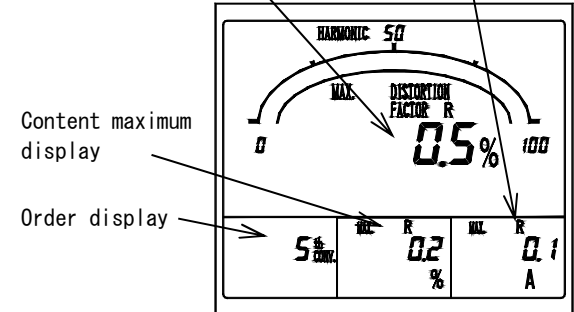

Current harmonic measurement maximum display.

Distortion-factor display      Effective-value display

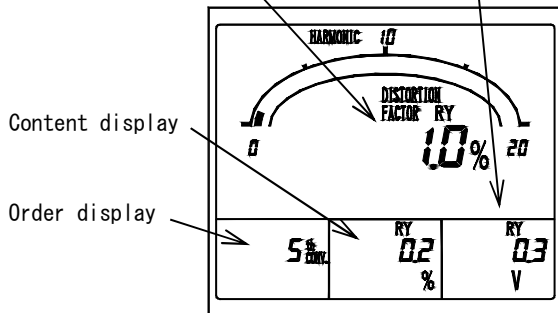

Voltage harmonic measurement display.

Distortion-factor maximum display      Effective-value maximum display

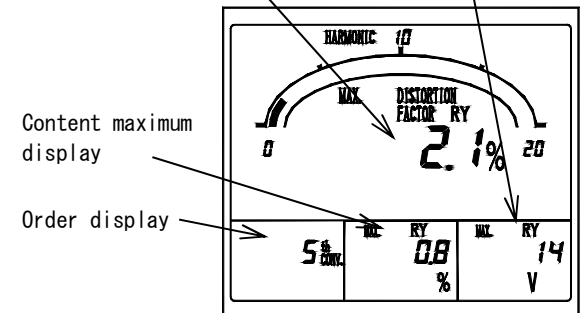

Voltage harmonic measurement maximum display.

4.2.2 Alarm detection display

The alarm value setting is a possible measurement factor (demand current and harmonic, etc.), it displays in case an input exceeds a set point.

Besides the usual measurement display, the detected factor is displayed on a screen upper case.

In addition, in case setting OFF (not use) as measurement factor, it does not detect.

And in the case of with an alarm-output option, it is possible to do an alarm output (relay make contact) to the outside simultaneously with a screen display.

Alarm display possible factor) Demand current, Demand, Harmonic distortion factor (current, voltage), Harmonic 5th conversion content (current, voltage), Harmonic nth content (current, voltage n=3, 4, 5, 7, 9, 11, 13, 15), Voltage, Current leakage

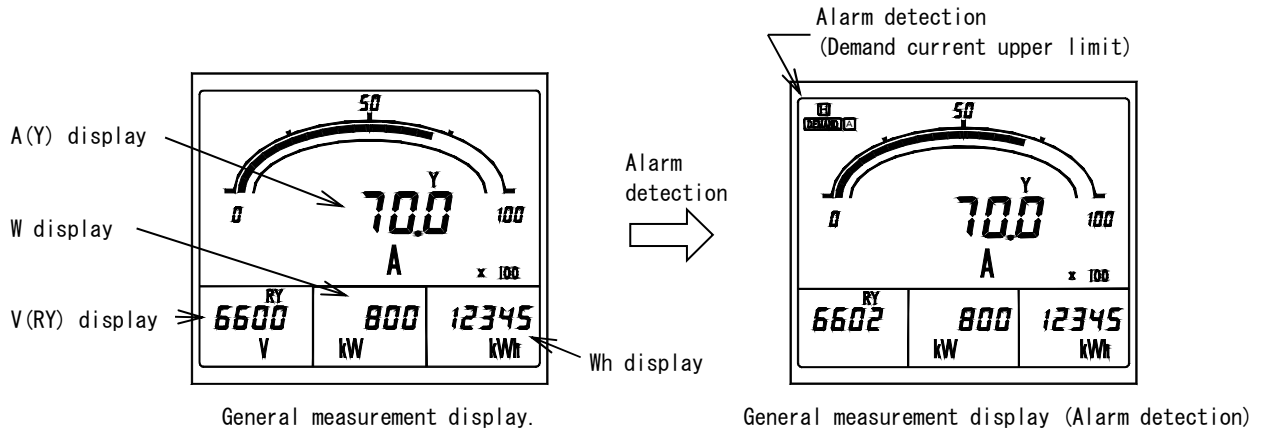

The example of a display at the case of the detection in each alarm factor.

In case the alarm factor is indicating by measurement at the main monitor or the sub-monitor, a measurement value constitutes a blinking display.

The displays after an alarm return.

In case a return method is automatic reset setting: It returns to the usual measurement display.

In case a return method is manual reset setting

: A detection display and an alarm output hold (in case setting as an alarm output of applicable factor).

The return in this case needs alarm reset operation. Please refer to "4.3.7 Reset" about alarm reset.

| Alarm factor   |                 | Example of a display                                                             | Alarm factor                            |                 | Example of a display |
|----------------|-----------------|----------------------------------------------------------------------------------|-----------------------------------------|-----------------|----------------------|
| Demand current | Upper limit (H) |                                                                                  | Voltage harmonic 5th conversion content | Upper limit (H) |                      |
|                |                 | Setting as 5th conversion content of bar graph (It distinguishes in an underbar) |                                         |                 |                      |

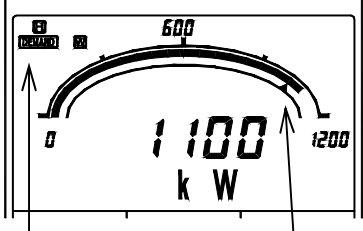
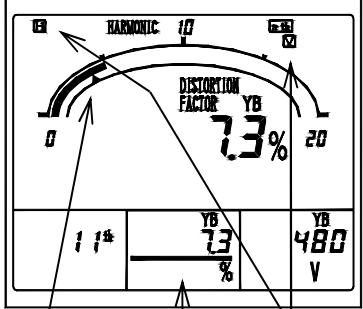
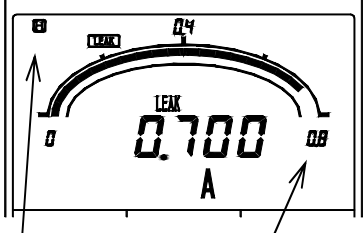
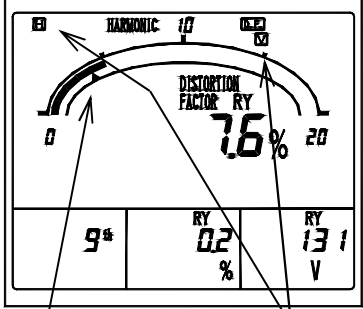
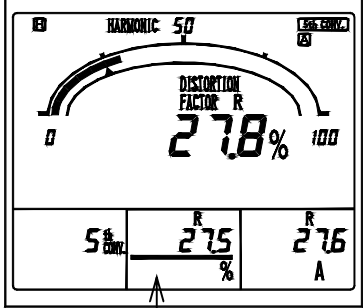
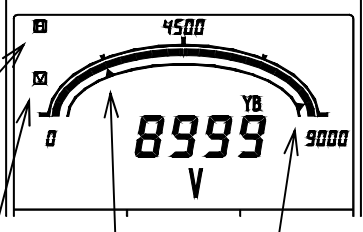
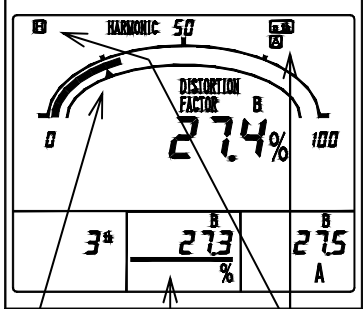
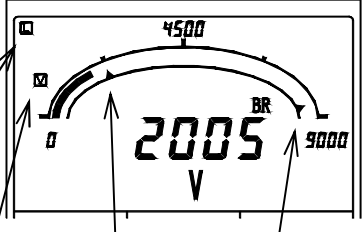
| Alarm factor                            | Example of a display                                                                                                                                                                                                 | Alarm factor                 | Example of a display                                                                                                                                                                                                  |
|-----------------------------------------|----------------------------------------------------------------------------------------------------------------------------------------------------------------------------------------------------------------------|------------------------------|-----------------------------------------------------------------------------------------------------------------------------------------------------------------------------------------------------------------------|
| Demand                                  |  <p>Detection display</p> <p>Alarm setting value</p>                                                                                | Voltage harmonic nth content |  <p>Alarm setting Value</p> <p>Detection display</p> <p>Setting as 11th content of bar graph (It distinguishes in an underbar)</p> |
| Current leakage                         |  <p>Detection display</p> <p>Rated sensitivity current value</p>                                                                    | Voltage distortion factor    |  <p>Alarm setting Value</p> <p>Detection display</p>                                                                               |
| Current harmonic 5th conversion content |  <p>Setting as 5th conversion content of bar graph (It distinguishes in an underbar)</p>                                          | Voltage                      |  <p>Detection Display</p> <p>Upper limit (H) alarm set point</p> <p>Lower limit (L) alarm set point</p>                          |
| Current harmonic nth content            |  <p>Alarm setting value</p> <p>Detection display</p> <p>Setting as 3th content of bar graph (It distinguishes in an underbar)</p> | Voltage                      |  <p>Detection Display</p> <p>Upper limit (H) alarm set point</p> <p>Lower limit (L) alarm set point</p>                          |



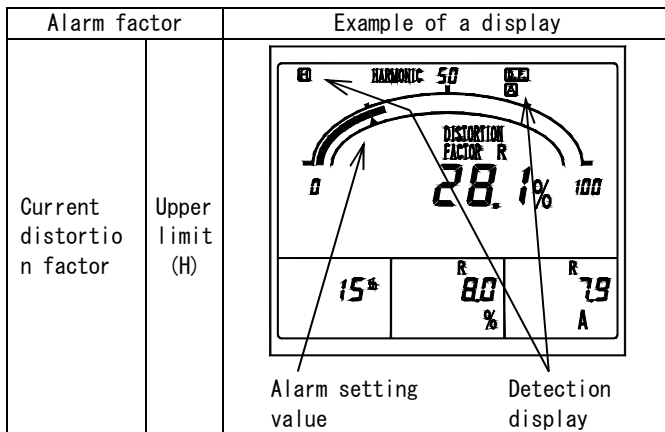

4.2.3 Setting display

It is the display at the case of various setting. There are three types of setting modes according to the contents of a setting.

Refer to "5. Setting" for the operation in setting mode, and the detailed contents of a setting.

① Setting mode 1

Setting of a measurement display element, an alarm output, and an alarm value is mainly performed. And, an alarm output can be tested in this setting mode.

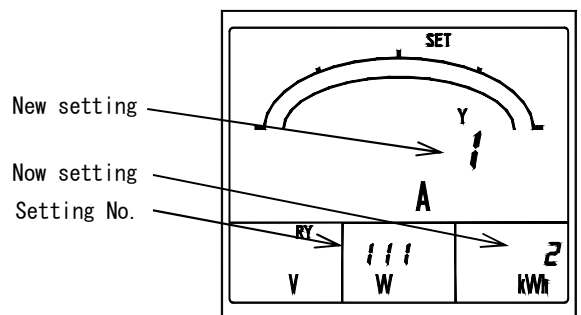

Setting mode 1 (No.111 Display pattern)

② Setting mode 2

Setting of measurement range, analog output, pulse output, and measurement display ON/OFF is mainly performed. And, initialization of a setting value and reset of watt-hour integrated value can be performed in this setting mode.

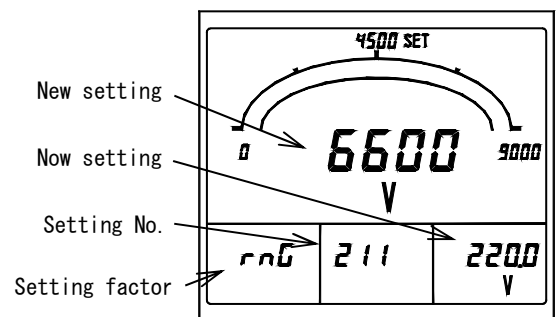

Setting mode 2 (No.211 Voltage range)

③ Setting mode 3

Setting of an input circuit and tidal current measurement is mainly performed. And, analog output can be adjusted in this setting mode.

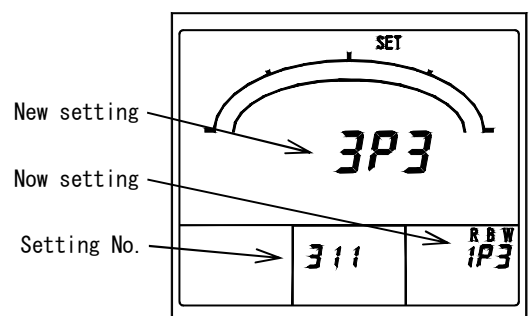

Setting mode 3 (No.311 Input circuit phase line change)

4.3 Operation

4.3.1 The main monitor display-element change

The measurement display element of the main monitor is changed. A change is performed by  $\boxed{+}$   $\boxed{-}$ . This operation can be performed also except a general measurement display (harmonic measurement display, maximum display and minimum display). However, in a harmonic measurement display, a sub-monitor changes with a harmonic order. (The main monitor is distortion-factor fixation.)

After changing a measurement display element, if a switch is not operated for 10 minutes, it will return to the original measurement display element automatically.

In a harmonic measurement display and maximum display and minimum display, even if a switch is not operated for 10 minutes, it does not return to the original display.

Setting can perform same operation in external operation input. Please refer to "5.3.2 Setting mode 2, (4) external operation input setting" about the setting method. Please refer to "6.3 Option specification" about external operation input.

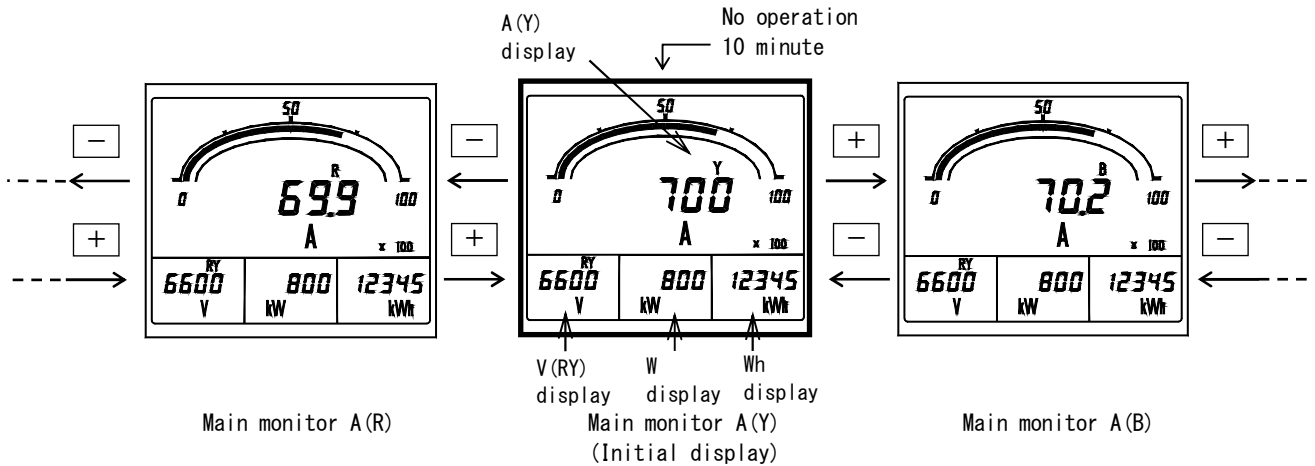

4.3.2 Phase (line) display change

A phase (line) display of current or voltage is changed. (Everything which is being indicated)

A change is performed by  $\boxed{\text{DISPLAY}}$ . This operation can be performed also except a general measurement display (harmonic measurement display, maximum display and minimum display).

In addition, after changing a phase (line) display, if a switch is not operated for 10 minutes, it will return to the original phase (line) display automatically.

In a harmonic measurement display and maximum display and minimum display, even if a switch is not operated for 10 minutes, it does not return to the original display.

Setting can perform same operation in external operation input. Please refer to "5.3.2 Setting mode 2, (4) external operation input setting" about the setting method. Please refer to "6.3 Option specification" about external operation input.

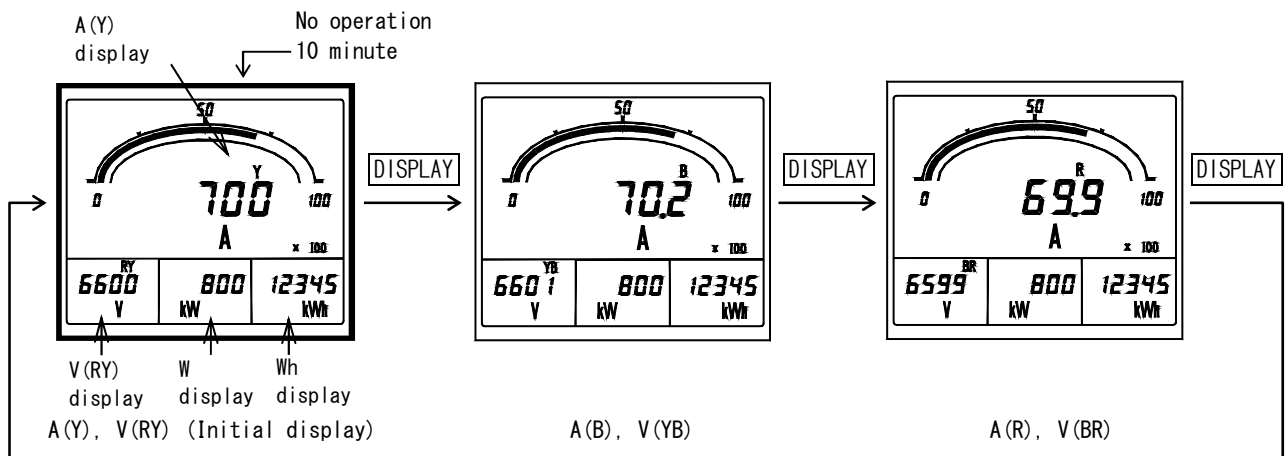

4.3.3 Harmonic measurement display change

A general measurement display and a harmonic measurement display are changed. A change is performed by **MODE**. Whenever it pushes a switch, it changes as follows. General measurement display → Current harmonic measurement display → Voltage harmonic measurement display → General measurement display ... This operation can also perform the maximum display and minimum display. In that case, it changes in order of a next. General measurement maximum and the minimum display → Current harmonic measurement maximum display → Voltage harmonic measurement maximum display → General measurement maximum and the minimum display ... In addition, about this operation, even if it does not do switch operation for 10 minutes, it does not return to the original display.

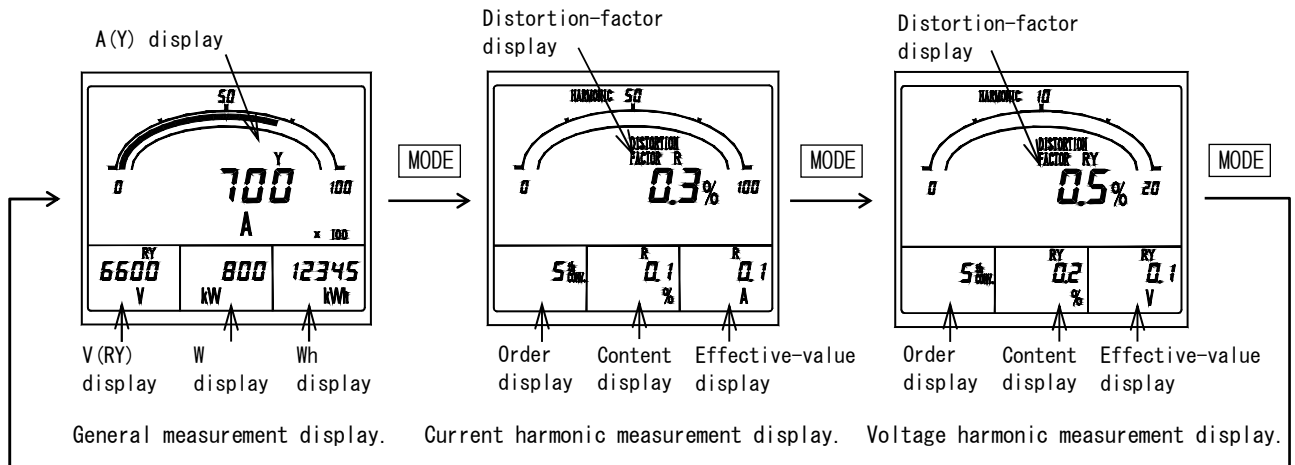

4.3.4 Watt-hour enlarged display

In case electric energy is being displayed by the general measurement display, an electric-energy display is usually changed to a display (5 digits of integers), and an enlarged display (2 digits integer + below decimal point, 3 digits). A change is performed by **SET**. After an enlarged display, if a switch is not operated for 10 minutes, it returns to the usual display automatically.

<Caution > If it continues pushing **SET** 3 seconds or more, it will become the setting mode 1. (An electric-energy display does not change)

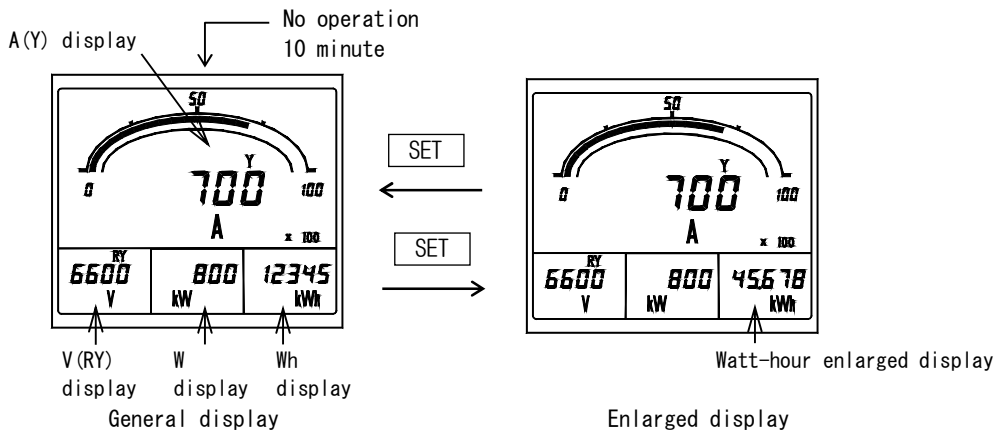

4.3.5 Setting value check

A voltage range (VT ratio), a current range (CT ratio), and an alarm-output set point are checked.

Check is **RESET/SHIFT** and **-** are pushed simultaneously and performed.

The change of a set point is carried out by **+** and **-**.

This operation can be performed also except a general measurement display (harmonic measurement display, maximum display and minimum display). **DISPLAY** is pushed in case it returns to the original measurement display.

And, if a switch is not operated for 10 seconds after a set point check, it will return to the original measurement display automatically.

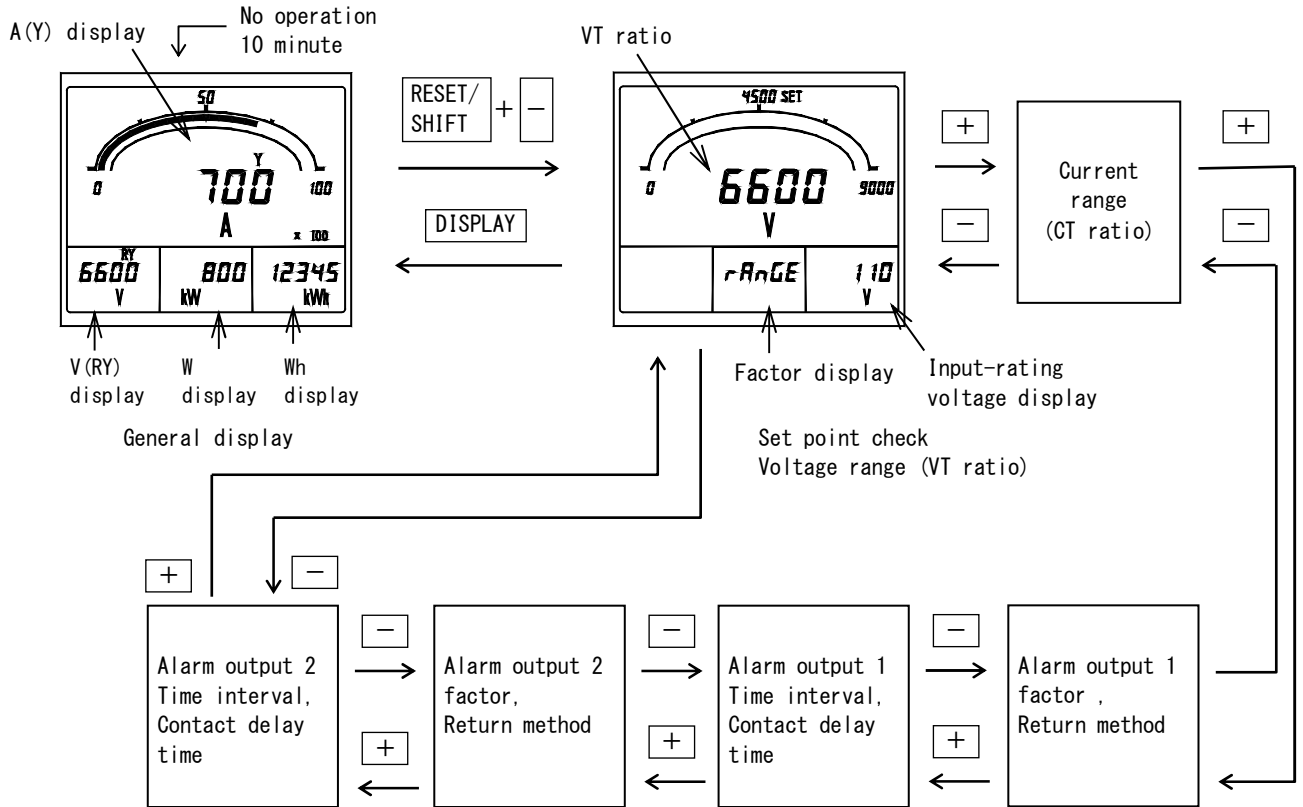

4.3.6 Setting mode

Various kinds of setting are performed. Setting mode is three types, and operations are different.

**DISPLAY** is pushed in case it returns to the original measurement display. And, if a switch is not operated for 10 minute after a set point check, it will return to the original measurement display automatically.

Operation and the contents of setting (detail) in setting mode, please refer to "5 Setting".

- Setting mode 1 : Press **SET** for longer than 3 seconds.
- Setting mode 2 : Press **SET** and **RESET/SHIFT** together for longer than 3 seconds.
- Setting mode 3 : Press **SET** and **DISPLAY** together for longer than 3 seconds.

<Reference> This operation can be performed also except a general measurement display (harmonic measurement display, maximum display and minimum display).

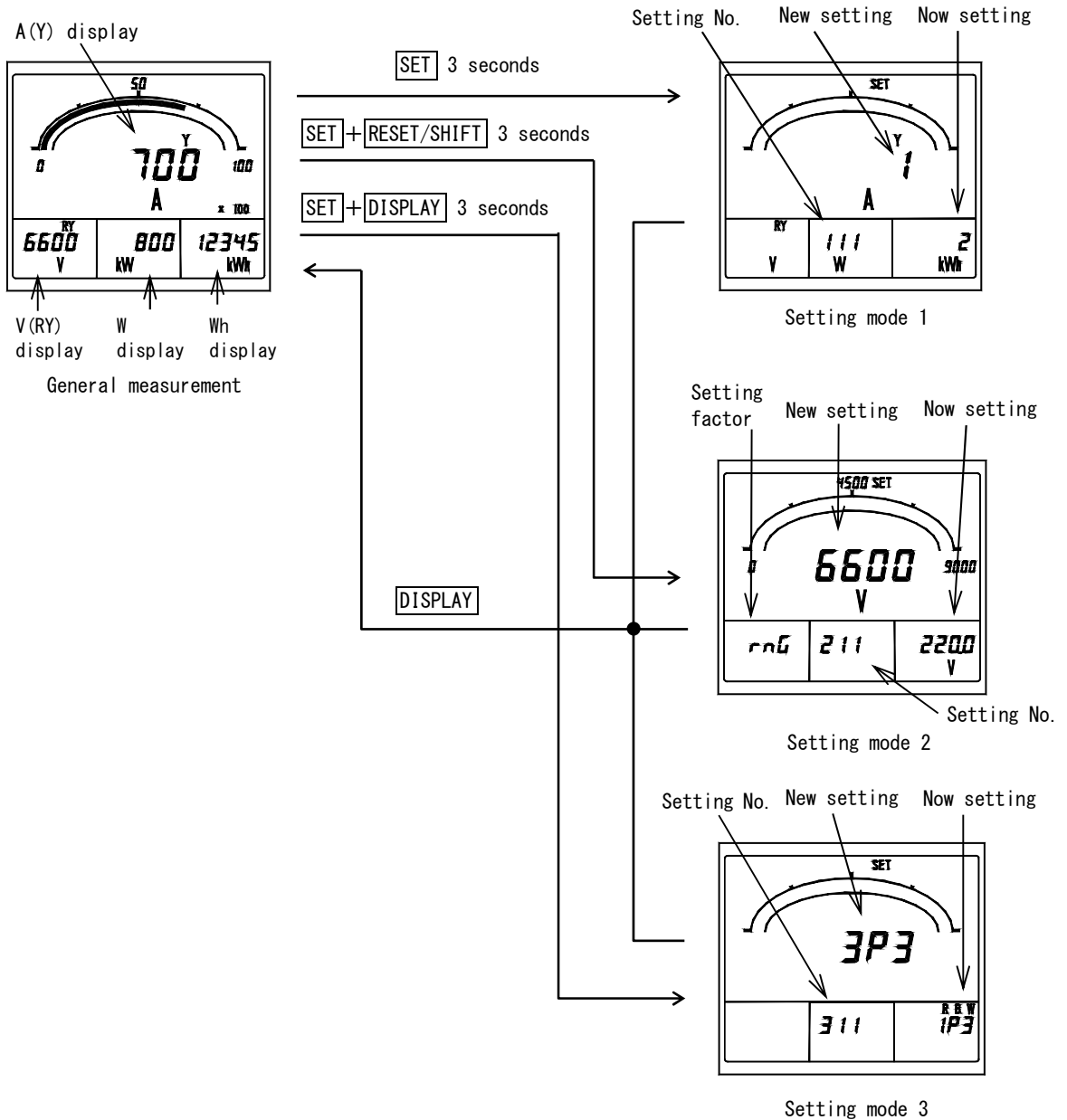

4.3.7 Reset

Various kinds of reset are performed. The kind of reset is as follows and operations are different, respectively.  
 Reset of watt-hour integrated value (zero clear),  
 Reset of maximum value and minimum value (it updates to the instantaneous value at the time),  
 Alarm-output reset (OFF of an alarm output (at the case of manual reset setting)).  
 And, the operation from each measurement display constitutes conditions at each reset.

(1) Watt-hour integrated-value reset

It resets by package about the integrated value of various watt-hour. Watt-hour reset is performed in the setting mode 2. In detail explanation in the setting mode 2, please refer to "5.3.2 Setting mode 2".

- ① Press **SET** and **RESET/SHIFT** together for longer than 3 seconds. It goes into the setting mode 2.
- ② **MODE** is pushed until setting is set to No.271. Further **RESET/SHIFT** is pushed once and it is made a watt-hour-reset display.
- ③ Press **SET** for longer than 3 seconds.
- ④ **DISPLAY** is pushed and it returns to a measurement display.

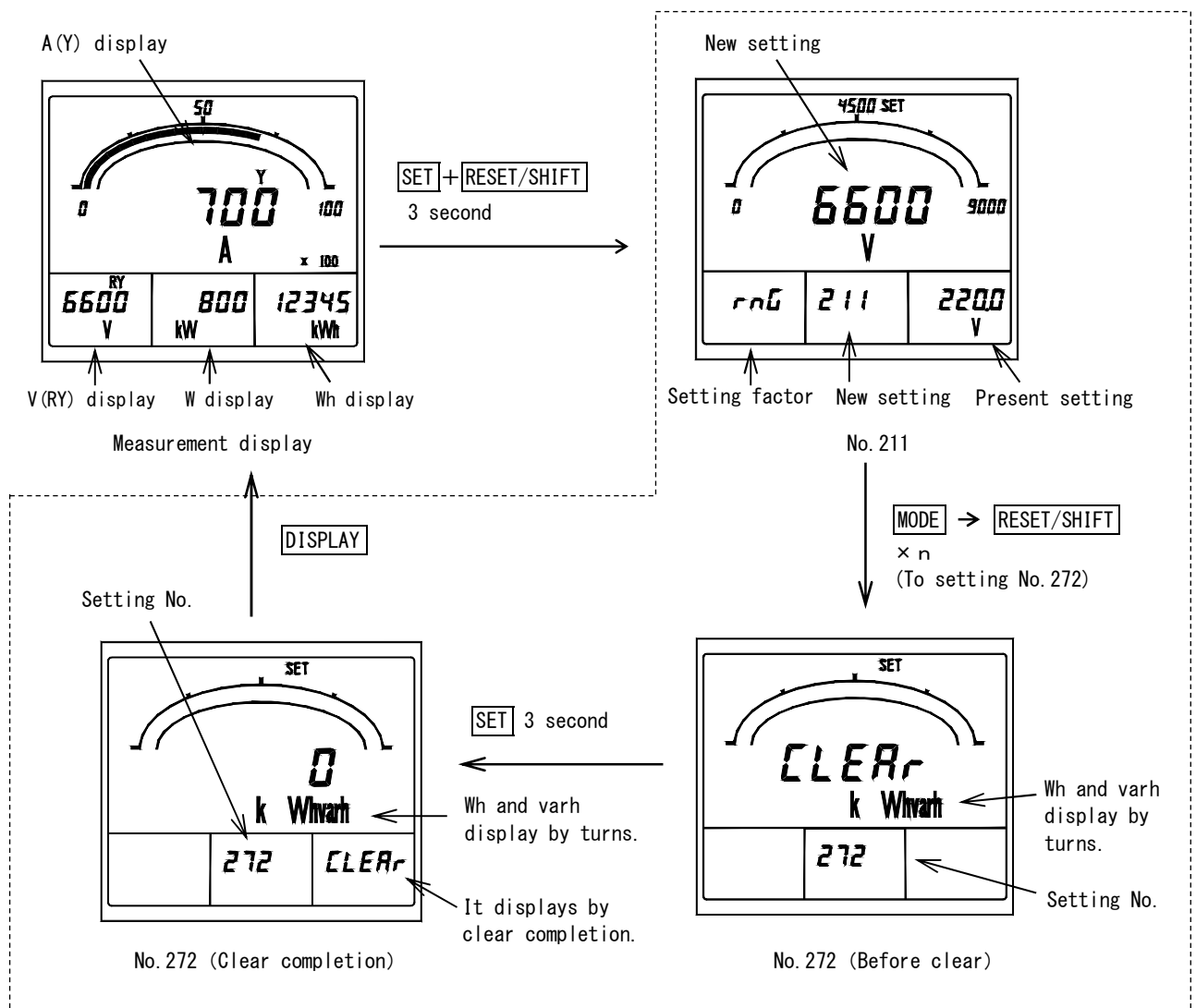

Setting mode 2

(2) Reset of maximum value and minimum value

Reset of the various measurement values of maximum value and minimum value is performed.

This reset has two types of methods. (How to perform according to a measurement factor individual. How to reset all maximum values and minimum values by package.)

a) Individual reset

Reset of only a certain differential maximum value or the minimum value is performed. Other maximum values and minimum values are not reset by this operation.

- ① A measurement factor to reset is displayed. (General measurement maximum value, minimum value, or Current, voltage harmonic measurement maximum display)
- ② Press **RESET/SHIFT** for longer than 1 seconds.

<Caution> An alarm output will be reset if this operation is performed by instant measurement display. Please be sure to perform this operation after displaying the maximum value and a minimum value measurement factor to make it reset.

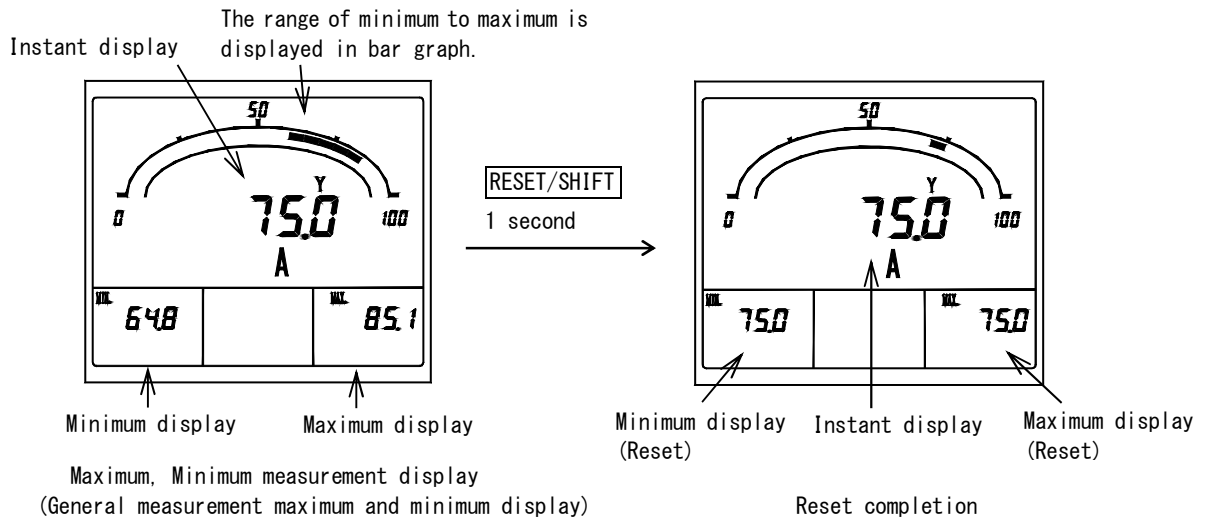

b) Package reset

Reset of all the maximum values and minimum value is performed.

In addition, setting can perform same operation in external operation input.

Please refer to "5.3.2 Setting mode 2 (4) external operation input setting" for the setting method,

Please refer to "6.3 Option" for the external operation input,

- ① Press **RESET/SHIFT** and **+** together for longer than 1 seconds. By the maximum and the minimum measurement display (The general measurement maximum and minimum display or current, voltage harmonic measurement maximum display).

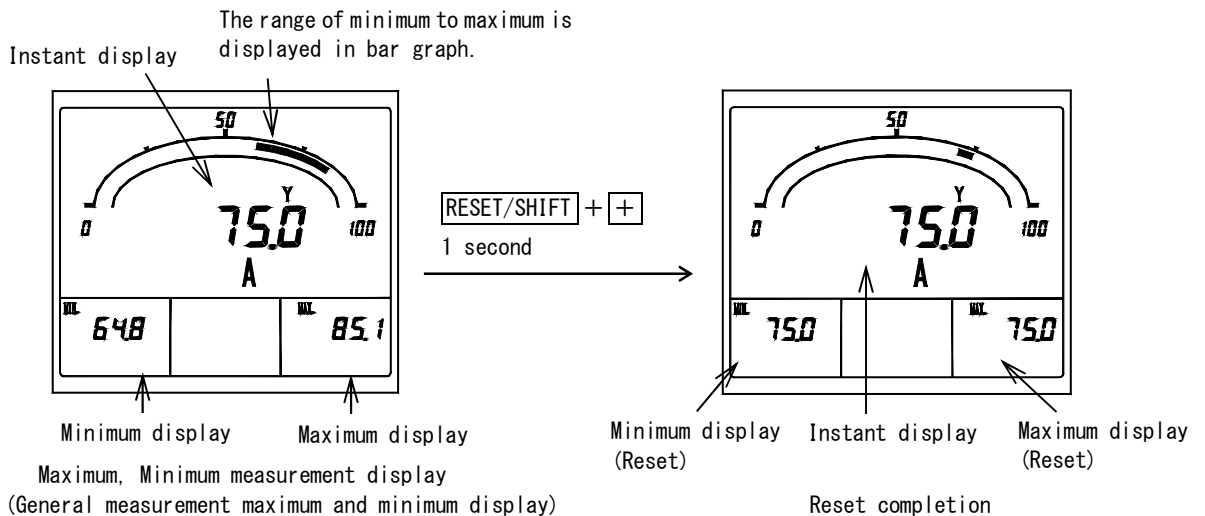

<Caution> In the general measurement maximum and minimum value reset, all the factors of general measurement are reset by package. (The harmonic measurement maximum value is not reset.) By harmonic measurement maximum value reset, a current factor and a voltage factor are reset by package. (The general measurement maximum value and the minimum value are not reset.)

(3) Alarm reset

In case an alarm return method is set to "HOLD (manual return)", an alarm output is reset (output OFF).

(With an alarm-output option)

However, an output is not turned off by this operation, in case an alarm continues and it has caused.

And, this operation is unnecessary in case setting as "AUTO (automatic return)" in alarm return method. (By which an output is also OFF according to an alarm return.)

In case the number of alarm outputs is two, both outputs are reset (output OFF) by this operation. (Return operation that comes out individually cannot be performed.)

In addition, setting can perform same operation in external operation input.

Please refer to "5.3.2 Setting mode 2 (4) external operation input setting" for the setting method,

Please refer to "6.3 Option" for the external operation input.

- ① By instant measurement display (a general measurement display or current, voltage harmonic measurement display), RESET/SHIFT is pushed 1 second or more.

<Caution> If this operation is performed by the maximum and the minimum measurement display, the maximum value and minimum value of the measurement factor currently displayed will be reset.

Please be sure to perform this operation in the state of an instant measurement display.

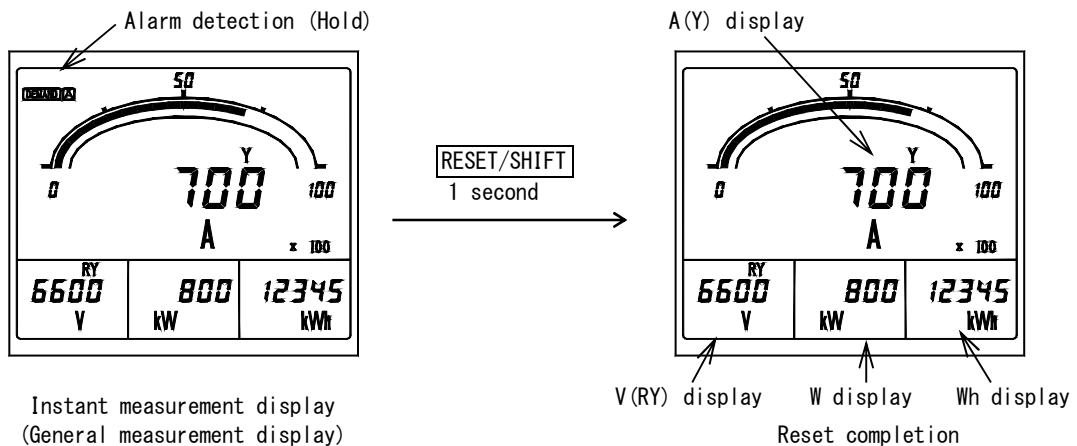



## 5. Setting

## &lt; Caution &gt;

When changing the input circuit setting, please be sure to perform a setup from an input circuit setting in the setting mode 3. After changing the other setting, when the input circuit setting is changed the set value returns to default value (default value of a changed input circuit).

## 5.1 Function table

This product has each function setting with a front switch.

<Caution> In case the input circuit is not designated at the case of an order, it is shipping in the default value of 3-phase 3-wire.

Setting mode 1. Function table (1)

| Set No.               | Function                               | Functional description                                                               | Current input | Voltage input | Default setting       | Important setting | Page   |
|-----------------------|----------------------------------------|--------------------------------------------------------------------------------------|---------------|---------------|-----------------------|-------------------|--------|
| 111                   | Display pattern                        | Set the display combination pattern of the digital 4 displays and bar graph display. | ○             | ○             | Pattern 1             | ○                 | 47~51  |
| 112                   | Main monitor                           | Set the display factor of digital main monitor.                                      | ○             | ○             | 3 φ 3W A (Y)          | ○                 | 47~51  |
|                       |                                        |                                                                                      |               |               | 1 φ 3W A (R)          |                   |        |
|                       |                                        |                                                                                      |               |               | 1 φ 2W A              |                   |        |
| 113                   | sub-monitor (left)                     | Set the display factor of digital sub-monitor (left).                                | ○             | ○             | 3 φ 3W V (RY)         | ○                 | 47~51  |
|                       |                                        |                                                                                      |               |               | 1 φ 3W V (RW)         |                   |        |
|                       |                                        |                                                                                      |               |               | 1 φ 2W V              |                   |        |
| 114                   | sub-monitor (center)                   | Set the display factor of digital sub-monitor (center).                              | ○             | ○             | W                     | ○                 | 47~51  |
| 115                   | sub-monitor (right)                    | Set the display factor of digital sub-monitor (right).                               | ○             | ○             | Wh                    | ○                 | 47~51  |
| 116                   | Bar graph                              | Set the display factor of bar graph.                                                 | ○             | ○             | 3 φ 3W A (Y)          | ○                 | 47~51  |
|                       |                                        |                                                                                      |               |               | 1 φ 3W A (R)          |                   |        |
|                       |                                        |                                                                                      |               |               | 1 φ 2W A              |                   |        |
| 121AL <sup>(26)</sup> | Alarm 1 factor                         | Set the output factor of alarm 1.                                                    | ○             | ○             | DA                    | ○                 | 52     |
| 122AL <sup>(26)</sup> | Alarm 1 return method                  | Set the output action at the case of reset of alarm 1.                               | ○             | ○             | Automatic reset       |                   | 52     |
| 123AL <sup>(26)</sup> | Alarm 1 mask time (Contact delay time) | Set the contact delay time of alarm 1.                                               | ○             | ○             | 0 second              |                   | 52     |
| 124AL <sup>(26)</sup> | Alarm 1 test                           | Output test of alarm 1 is performed.                                                 | ○             | ○             | —                     |                   | 52     |
| 125AL <sup>(26)</sup> | Alarm 2 factor                         | Set the output factor of alarm 2.                                                    | ○             | ○             | DA                    | ○                 | 52     |
| 126AL <sup>(26)</sup> | Alarm 2 return method                  | Set the output action at the case of reset of alarm 2.                               | ○             | ○             | Automatic reset       |                   | 52     |
| 127AL <sup>(26)</sup> | Alarm 2 mask time (Contact delay time) | Set the contact delay time of alarm 2.                                               | ○             | ○             | 0 second              |                   | 52     |
| 128AL <sup>(26)</sup> | Alarm 2 test                           | Output test of alarm 2 is performed.                                                 | ○             | ○             | —                     |                   | 52     |
| 131H                  | Demand current upper limit             | Sets the high-alarm value of demand current.                                         | ○             |               | 80% (Full scale=100%) |                   | 53, 54 |
| 132                   | Demand current time interval           | Set time interval of demand current.                                                 | ○             |               | 0 second              | ○                 | 53, 54 |
| 133H                  | Demand active power upper limit        | Set the high-alarm value of demand active power.                                     |               |               | OFF (No operation)    |                   | 53, 54 |
| 134                   | Demand active power time interval      | Set the time interval of demand active power.                                        |               |               | 0 second              | ○                 | 53, 54 |

Note<sup>(26)</sup> A setting item is not displayed in case there is no corresponding option.

Setting mode 1. Function table (2)

| Set No.                             | Function                                          | Functional description                                                                    | Current input | Voltage input | Default setting                                  | Important setting | Page   |
|-------------------------------------|---------------------------------------------------|-------------------------------------------------------------------------------------------|---------------|---------------|--------------------------------------------------|-------------------|--------|
| 135                                 | Demand active power operating method              | Set the operating method of demand active power.                                          |               |               | Operating system according with bimetallic type. | ○                 | 53, 54 |
| 136                                 | Power-factor operating method                     | Set the operating method of power-factor measurement.                                     |               |               | Instant measurement                              |                   | 53, 54 |
| 141H                                | Current distortion-factor upper limit             | Set the high-alarm value of current distortion factor.                                    | ○             |               | OFF (No operation)                               |                   | 54, 55 |
| 142H                                | Current 5th conversion content upper limit        | Set the high-alarm value of current 5th conversion content.                               | ○             |               | OFF (No operation)                               |                   | 54, 55 |
| 143                                 | Current n-th content factor                       | Set the order of n-th current content.                                                    | ○             |               | 5th                                              |                   | 54, 55 |
| 144H                                | Current n-th content upper limit                  | Set the high-alarm value of current n-th content.                                         | ○             |               | OFF (No operation)                               |                   | 54, 55 |
| 145H                                | Voltage distortion-factor upper limit             | Set this high-alarm value of voltage distortion factor.                                   |               | ○             | OFF (No operation)                               |                   | 54, 55 |
| 146H                                | Voltage 5th conversion content upper limit        | Set the high-alarm value of voltage 5th conversion content.                               |               | ○             | OFF (No operation)                               |                   | 54, 55 |
| 147                                 | Voltage n-th content factor                       | Set the order of n-th voltage content.                                                    |               | ○             | 5th                                              |                   | 54, 55 |
| 148H                                | Voltage n-th content upper limit                  | Set the high-alarm value of voltage n-th content.                                         |               | ○             | OFF (No operation)                               |                   | 54, 55 |
| 149                                 | 5th conversion detection characteristics          | Set the detection characteristic of 5th conversion content.                               | ○             | ○             | Inverse-time-delay mode                          |                   | 54, 55 |
| 14A                                 | Average value time interval                       | Set the average value detection time interval of harmonic.                                | ○             | ○             | 0 minute                                         |                   | 54, 55 |
| 151H                                | Instant measurement voltage upper limit           | Set the high-alarm value of instant voltage.                                              |               | ○             | OFF (No operation)                               |                   | 55     |
| 152L                                | Instant measurement voltage lower limit           | Set the low-alarm value of instant voltage.                                               |               | ○             | OFF (No operation)                               |                   | 55     |
| 161 <sup>(27)</sup>                 | Leakage detection rated sensitivity current value | Set the rated sensitivity current value of current leakage.                               | ○             | ○             | 0.1A                                             |                   | 56     |
| 162 <sup>(27)</sup> <sup>(28)</sup> | Leakage detection factor change                   | Set the factor of the current leakage that performs leakage detection.                    | ○             | ○             | I <sub>o</sub>                                   |                   | 56     |
| 163 <sup>(27)</sup>                 | Leakage detect-circuitry change                   | Set the circuit configuration at the time that 3-phase 3-wire performs leakage detection. | ○             | ○             | One phase earth                                  |                   | 56     |
| 164 <sup>(27)</sup>                 | Selection of ZCT used                             | Sets the ZCT used by current-leakage measurement.                                         | ○             | ○             | TYPE 0                                           |                   | 56     |
| 171                                 | Backlight action                                  | Set the ON/OFF of backlight.                                                              | ○             | ○             | AUTO OFF                                         |                   | 57     |
| 172 <sup>(29)</sup>                 | Backlight brightness                              | Set the brightness of backlight.                                                          | ○             | ○             | 3 (Middle)                                       |                   | 57     |

Note<sup>(27)</sup> A setting item is not displayed in case there is no corresponding option.

Note<sup>(28)</sup> Current input product are only I<sub>o</sub> detection. I<sub>gr</sub> detection cannot be performed.

Note<sup>(29)</sup> In the case of green backlight, it does not indicate the setting item of brightness.

Setting mode 2. Function table (1)

| Set No.              | Function                                   | Functional description                                                                                                           | Current input | Voltage input | Default setting    |                          | Important setting | Page   |
|----------------------|--------------------------------------------|----------------------------------------------------------------------------------------------------------------------------------|---------------|---------------|--------------------|--------------------------|-------------------|--------|
|                      |                                            |                                                                                                                                  |               |               |                    |                          |                   |        |
| 211                  | Voltage range                              | Set the voltage-measurement range (VT ratio).                                                                                    |               | ○             | 3 $\phi$ 3W        | 6600V <sup>(31)</sup>    | ○                 | 58~60  |
|                      |                                            |                                                                                                                                  |               |               | 1 $\phi$ 3W        | 110.0V                   |                   |        |
|                      |                                            |                                                                                                                                  |               |               | 1 $\phi$ 2W        | 3300V <sup>(31)</sup>    |                   |        |
| 212                  | Current range                              | Set the current-measurement range (CT ratio).                                                                                    | ○             |               | 3 $\phi$ 3W        | 100.0A                   | ○                 | 58~60  |
|                      |                                            |                                                                                                                                  |               |               | 1 $\phi$ 3W        | 500A                     |                   |        |
|                      |                                            |                                                                                                                                  |               |               | 1 $\phi$ 2W        | 50.0A                    |                   |        |
| 213                  | Current display peculiar sensitivity       | Set the full scale of current meter.                                                                                             | ○             |               | 3 $\phi$ 3W        | 100.0A                   |                   | 58~60  |
|                      |                                            |                                                                                                                                  |               |               | 1 $\phi$ 3W        | 500A                     |                   |        |
|                      |                                            |                                                                                                                                  |               |               | 1 $\phi$ 2W        | 50.0A                    |                   |        |
| 214                  | Active power polarity                      | Set the swing display of active power meter.                                                                                     |               |               | One-side swing     |                          |                   | 58~60  |
| 215                  | Active power range                         | Set the full scale of active power meter.                                                                                        |               |               | 3 $\phi$ 3W        | 1200kW <sup>(32)</sup>   |                   | 58~60  |
|                      |                                            |                                                                                                                                  |               |               | 1 $\phi$ 3W        | 100.0kW                  |                   |        |
|                      |                                            |                                                                                                                                  |               |               | 1 $\phi$ 2W        | 150.0kW <sup>(32)</sup>  |                   |        |
| 216                  | Reactive power range                       | Set the full scale of reactive power meter.                                                                                      |               |               | 3 $\phi$ 3W        | 600kvar <sup>(32)</sup>  |                   | 58~60  |
|                      |                                            |                                                                                                                                  |               |               | 1 $\phi$ 3W        | 50.0kvar                 |                   |        |
|                      |                                            |                                                                                                                                  |               |               | 1 $\phi$ 2W        | 75.0kvar <sup>(32)</sup> |                   |        |
| 217                  | Power-factor range                         | Set the full scale of power-factor meter. And, set this output range of analog output.                                           |               |               | 0.500~1.000~0.500  |                          |                   | 58~60  |
| 218                  | Frequency range                            | Set the full scale of frequency meter. And, set this output range of analog output.                                              |               | ○             | 45.0~65.0Hz        |                          |                   | 58~60  |
| 221A <sup>(30)</sup> | A01 output factor                          | Set the output factor of A01 (analog output 1).                                                                                  | ○             | ○             | 3 $\phi$ 3W        | A (Y)                    | ○                 | 61, 62 |
|                      |                                            |                                                                                                                                  |               |               | 1 $\phi$ 3W        | A (R)                    |                   |        |
|                      |                                            |                                                                                                                                  |               |               | 1 $\phi$ 2W        | A                        |                   |        |
| 222A <sup>(30)</sup> | A02 output factor                          | Set the output factor of A02 (analog output 2).                                                                                  | ○             | ○             | 3 $\phi$ 3W        | V (RY)                   | ○                 | 61, 62 |
|                      |                                            |                                                                                                                                  |               |               | 1 $\phi$ 3W        | V (RW)                   |                   |        |
|                      |                                            |                                                                                                                                  |               |               | 1 $\phi$ 2W        | V                        |                   |        |
| 223A <sup>(30)</sup> | A03 output factor                          | Set the output factor of A03 (analog output 3).                                                                                  | ○             | ○             | W                  |                          | ○                 | 61, 62 |
| 224A <sup>(30)</sup> | A04 output factor                          | Set the output factor of A04 (analog output 4).                                                                                  | ○             | ○             | cos $\phi$         |                          | ○                 | 61, 62 |
| 225A <sup>(30)</sup> | Current output peculiar sensitivity        | Set the analog output sensitivity (% of output for input) of current.                                                            | ○             |               | 100.0%             |                          |                   | 61, 62 |
| 226A <sup>(30)</sup> | Active power-output peculiar sensitivity   | Set the analog output sensitivity (% of output for input) of active power.                                                       |               |               | 100.0%             |                          |                   | 61, 62 |
| 227A <sup>(30)</sup> | Reactive power output peculiar sensitivity | Set the analog output sensitivity (% of output for input) of reactive power.                                                     |               |               | 50.0%              |                          |                   | 61, 62 |
| 228A <sup>(30)</sup> | Low input cut                              | Set the function which makes a lower limit the output at the case of a minute input (adequate to 0.5% or less) in analog output. | ○             | ○             | OFF (No operation) |                          |                   | 61, 62 |

Note<sup>(30)</sup> A setting item is not displayed in case there is no corresponding option.

Note<sup>(31)</sup> In 220V input, it becomes "220V".

Note<sup>(32)</sup> In 220V input, It becomes "40.0kW" and "20.00kvar" (3  $\phi$  3W).

In 220V input, It becomes "10.00kW" and "5.00kvar" (1  $\phi$  2W).

Setting mode 2. Function table (2)

| Set No.                              | Function                                       | Functional description                                                         | Current input | Voltage input | Default setting                                              | Important setting | Page |
|--------------------------------------|------------------------------------------------|--------------------------------------------------------------------------------|---------------|---------------|--------------------------------------------------------------|-------------------|------|
| 241P <sup>(33)</sup>                 | P01 factor                                     | Set the output factor of P01 (pulse output 1).                                 |               |               | Wh                                                           | ○                 | 62   |
| 242P <sup>(33)</sup> <sup>(34)</sup> | P01 pulse unit                                 | Set the output pulse unit of P01 (pulse output 1).                             |               |               | 3 $\phi$ 3W   10kWh/p<br>1 $\phi$ 3W   1kWh/p<br>1 $\phi$ 2W |                   | 62   |
| 243P <sup>(33)</sup>                 | P02 factor                                     | Set the output factor of P02 (pulse output 2).                                 |               |               | Wh                                                           | ○                 | 62   |
| 244P <sup>(33)</sup> <sup>(34)</sup> | P02 pulse unit                                 | Set the output pulse unit of P02 (pulse output 2).                             |               |               | 3 $\phi$ 3W   10kWh/p<br>1 $\phi$ 3W   1kWh/p<br>1 $\phi$ 2W |                   | 62   |
| 251 <sup>(33)</sup>                  | External operation input 1 function            | Set the function of the external operation input 1.                            | ○             | ○             | Alarm reset                                                  | ○                 | 63   |
| 252 <sup>(33)</sup>                  | External operation input 2 function            | Set the function of the external operation input 2.                            | ○             | ○             | Maximum / Minimum reset                                      | ○                 | 63   |
| 261                                  | Voltage ON/OFF                                 | Set the ON/OFF of voltage measurement display.                                 |               | ○             | ON                                                           |                   | 64   |
| 262                                  | Current ON/OFF                                 | Set the ON/OFF of current measurement display.                                 | ○             |               | ON                                                           |                   | 64   |
| 263                                  | Active power ON/OFF                            | Set the ON/OFF of active power measurement display.                            |               |               | ON                                                           |                   | 64   |
| 264                                  | Reactive power ON/OFF                          | Set the ON/OFF of reactive power measurement display.                          |               |               | ON                                                           |                   | 64   |
| 265                                  | Power-factor ON/OFF                            | Set the ON/OFF of power-factor measurement display.                            |               |               | ON                                                           |                   | 64   |
| 266                                  | Frequency ON/OFF                               | Set the ON/OFF of frequency measurement display.                               |               | ○             | ON                                                           |                   | 64   |
| 267                                  | Power-receiving watt-hour ON/OFF               | Set the ON/OFF of power-receiving watt-hour measurement display.               |               |               | ON                                                           |                   | 64   |
| 268                                  | Power transmission watt-hour ON/OFF            | Set the ON/OFF of power transmission watt-hour measurement display.            |               |               | ON                                                           |                   | 64   |
| 269                                  | Power-receiving var-hour (LAG, LEAD) ON/OFF    | Set the ON/OFF of power-receiving var-hour (LAG, LEAD) measurement display.    |               |               | ON                                                           |                   | 64   |
| 26A                                  | Power transmission var-hour (LAG, LEAD) ON/OFF | Set the ON/OFF of power transmission var-hour (LAG, LEAD) measurement display. |               |               | ON                                                           |                   | 64   |
| 26B                                  | Harmonic current ON/OFF                        | Set the ON/OFF of harmonic current measurement display.                        | ○             |               | ON                                                           |                   | 64   |
| 26C                                  | Harmonic voltage ON/OFF                        | Set the ON/OFF of harmonic voltage measurement display.                        |               | ○             | ON                                                           |                   | 64   |
| 26D <sup>(33)</sup>                  | Current leakage ON/OFF                         | Set the ON/OFF of current-leakage measurement display.                         | ○             | ○             | ON                                                           |                   | 64   |
| 271                                  | set value initialization                       | All set values are initialized. (Return to default setting)                    | ○             | ○             | —                                                            |                   | 64   |
| 272                                  | Watt-hour reset                                | Integrated value is cleared by package about each electric energy.             |               |               | —                                                            |                   | 64   |

Note<sup>(33)</sup> A setting item is not displayed in case there is no corresponding option.

Note<sup>(34)</sup> In 220V input, it becomes "0.1kWh/p". (3 $\phi$  3W, 1 $\phi$  2W)

Setting mode 3. Function table

| Set No.                                    | Function                        | Functional description                                                                                                                                                   | Current input | Voltage input | Default setting                |                     | Important setting | Page |
|--------------------------------------------|---------------------------------|--------------------------------------------------------------------------------------------------------------------------------------------------------------------------|---------------|---------------|--------------------------------|---------------------|-------------------|------|
|                                            |                                 |                                                                                                                                                                          |               |               |                                |                     |                   |      |
| 311                                        | Input circuit phase line change | Set the input circuit or phase line.                                                                                                                                     | ○             | ○             | 3 $\phi$ 3W                    | 3 $\phi$ 3W         | ○                 | 66   |
|                                            |                                 |                                                                                                                                                                          |               |               | 1 $\phi$ 3W                    | 1 $\phi$ 3W (R-W-B) |                   |      |
|                                            |                                 |                                                                                                                                                                          |               |               | 1 $\phi$ 2W                    | 1 $\phi$ 2W         |                   |      |
| 312                                        | Input voltage                   | Set the input voltage or phase-voltage full scale.                                                                                                                       |               | ○             | 3 $\phi$ 3W                    | 110V                | ○                 | 66   |
|                                            |                                 |                                                                                                                                                                          |               |               | 1 $\phi$ 3W                    | 300V                |                   |      |
|                                            |                                 |                                                                                                                                                                          |               |               | 1 $\phi$ 2W                    | 110V                |                   |      |
| 321                                        | Measurement dead band           | Set the dead band of measurement display.                                                                                                                                | ○             | ○             | 0.0%                           |                     |                   | 67   |
| 322                                        | Tidal current measurement       | Set the general measurement or tidal current measurement which was conscious of power transmission / power receiving, in measurement of reactive power and power-factor. |               |               | General measurement            |                     |                   | 67   |
| 331<br>( <sup>35</sup> ) ( <sup>36</sup> ) | Analog output specification     | Set the analog output specification.                                                                                                                                     | ○             | ○             | DC1~5V or DC0~5V (Designation) |                     |                   | 68   |
| 341<br>( <sup>35</sup> )                   | A01 BIAS adjustment             | Set the BIAS value of A01 (Analog output 1).                                                                                                                             | ○             | ○             | 0.0%                           |                     |                   | 68   |
| 342<br>( <sup>35</sup> )                   | A01 SPAN adjustment             | Set the SPAN value of A01 (Analog output 1).                                                                                                                             | ○             | ○             | 100.0%                         |                     |                   | 68   |
| 343<br>( <sup>35</sup> )                   | A02 BIAS adjustment             | Set the BIAS value of A02 (Analog output 2).                                                                                                                             | ○             | ○             | 0.0%                           |                     |                   | 68   |
| 344<br>( <sup>35</sup> )                   | A02 SPAN adjustment             | Set the SPAN value of A02 (Analog output 2).                                                                                                                             | ○             | ○             | 100.0%                         |                     |                   | 68   |
| 345<br>( <sup>35</sup> )                   | A03 BIAS adjustment             | Set the BIAS value of A03 (Analog output 3).                                                                                                                             | ○             | ○             | 0.0%                           |                     |                   | 68   |
| 346<br>( <sup>35</sup> )                   | A03 SPAN adjustment             | Set the SPAN value of A03 (Analog output 3).                                                                                                                             | ○             | ○             | 100.0%                         |                     |                   | 68   |
| 347<br>( <sup>35</sup> )                   | A04 BIAS adjustment             | Set the BIAS value of A04 (Analog output 4).                                                                                                                             | ○             | ○             | 0.0%                           |                     |                   | 68   |
| 348<br>( <sup>35</sup> )                   | A04 SPAN adjustment             | Set the SPAN value of A04 (Analog output 4).                                                                                                                             | ○             | ○             | 100.0%                         |                     |                   | 68   |

Note<sup>(35)</sup> A setting item is not displayed in case there is no corresponding option.

Note<sup>(36)</sup> A setting item is not displayed if analog output is except DC0-5V (or DC1-5V) specification, And analog output insulation product does not display a setting item.

## 5.2 Setting table

A setting item changes by the specification of a product, or the existence of an option.

## (1) Important setting

Each parenthesized number shows a setting number and this number is displayed on the setting screen.

| Items                                                  | Setting and operation procedures                                                                                                                                                                                                                                                                                                                                                       | Page   |
|--------------------------------------------------------|----------------------------------------------------------------------------------------------------------------------------------------------------------------------------------------------------------------------------------------------------------------------------------------------------------------------------------------------------------------------------------------|--------|
| Set the measurement range of voltmeter (211)           | Press <b>SET</b> and <b>RESET/SHIFT</b> together for longer than 3 seconds ➡ (211)<br>Select a measurement range by <b>+</b> and <b>-</b> ➡ Press <b>SET</b> ➡<br>Selected measurement range is entered ➡ Press <b>DISPLAY</b> ➡ Returns to display mode.                                                                                                                              | 58~60  |
| Set the measurement range of ammeter (212)             | Press <b>SET</b> and <b>RESET/SHIFT</b> together for longer than 3 seconds ➡ Press <b>RESET/SHIFT</b> ➡ (211) (212)<br>Select a measuring range by <b>+</b> and <b>-</b> ➡ Press <b>SET</b> ➡<br>Selected measuring range is entered ➡ Press <b>DISPLAY</b> ➡ Returns to display mode.                                                                                                 | 58~60  |
| Set the display combination (111)                      | Press <b>SET</b> for longer than 3 seconds ➡ Select the display combination by <b>+</b> and <b>-</b> ➡ (111)<br>Press <b>SET</b> ➡ Selected display combination is entered ➡ Press <b>DISPLAY</b> ➡<br>Returns to display mode.                                                                                                                                                        | 47~51  |
| Set the output factor of analog output 1 (A01). (221A) | Press <b>SET</b> and <b>RESET/SHIFT</b> together for longer than 3 seconds ➡ Press <b>MODE</b> ➡ (211) (221A)<br>Select an output factor by <b>+</b> and <b>-</b> ➡ Press <b>SET</b> ➡<br>Selected output factor is entered ➡ Press <b>DISPLAY</b> ➡ Returns to display mode.                                                                                                          | 61, 62 |
| Set the output factor of analog output 2 (A02). (222A) | Press <b>SET</b> and <b>RESET/SHIFT</b> together for longer than 3 seconds ➡ Press <b>MODE</b> ➡ (211) (221A)<br>Press <b>RESET/SHIFT</b> ➡ Select an output factor by <b>+</b> and <b>-</b> ➡ Press <b>SET</b> ➡ (222A)<br>Selected output factor is entered ➡ Press <b>DISPLAY</b> ➡ Returns to display mode.                                                                        | 61, 62 |
| Set the output factor of analog output 3 (A03). (223A) | Press <b>SET</b> and <b>RESET/SHIFT</b> together for longer than 3 seconds ➡ Press <b>MODE</b> ➡ (211) (221A)<br>Press <b>RESET/SHIFT</b> ➡ Press <b>RESET/SHIFT</b> ➡ Select an output factor by <b>+</b> and <b>-</b> ➡ (222A) (223A)<br>Press <b>SET</b> ➡ Selected output factor is entered ➡ Press <b>DISPLAY</b> ➡ Returns to display mode.                                      | 61, 62 |
| Set the output factor of analog output 4 (A04). (224A) | Press <b>SET</b> and <b>RESET/SHIFT</b> together for longer than 3 seconds ➡ Press <b>MODE</b> ➡ (211) (221A)<br>Press <b>RESET/SHIFT</b> ➡ Press <b>RESET/SHIFT</b> ➡ Press <b>RESET/SHIFT</b> ➡ (222A) (223A) (224A)<br>Select an output factor by <b>+</b> and <b>-</b> ➡ Press <b>SET</b> ➡ Selected output factor is entered<br>➡ Press <b>DISPLAY</b> ➡ Returns to display mode. | 61, 62 |
| Set the output factor of pulse output 1 (P01). (241P)  | Press <b>SET</b> and <b>RESET/SHIFT</b> together for longer than 3 seconds ➡ Press <b>MODE</b> ➡ (211) (221A)<br>Press <b>MODE</b> ➡ Select an output factor by <b>+</b> and <b>-</b> ➡ Press <b>SET</b> ➡ (241P)<br>Selected output factor is entered ➡ Press <b>DISPLAY</b> ➡ Returns to display mode.                                                                               | 62     |
| Set the output factor of pulse output 2 (P02). (243P)  | Press <b>SET</b> and <b>RESET/SHIFT</b> together for longer than 3 seconds ➡ Press <b>MODE</b> ➡ (211) (221A)<br>Press <b>MODE</b> ➡ Press <b>RESET/SHIFT</b> ➡ Press <b>RESET/SHIFT</b> ➡ (241P) (242P) (243P)<br>Select an output factor by <b>+</b> and <b>-</b> ➡ Press <b>SET</b> ➡<br>Selected output factor is entered ➡ Press <b>DISPLAY</b> ➡ Returns to display mode.        | 62     |

| Items                                                   | Setting and operation procedures                                                                                                                                                                                                                                                                                                                                                                                                                                                                                                                            | Page   |
|---------------------------------------------------------|-------------------------------------------------------------------------------------------------------------------------------------------------------------------------------------------------------------------------------------------------------------------------------------------------------------------------------------------------------------------------------------------------------------------------------------------------------------------------------------------------------------------------------------------------------------|--------|
| Set the factor of alarm output 1. (121AL)               | Press <b>SET</b> for longer than 3 seconds $\Rightarrow$ Press <b>MODE</b> $\Rightarrow$ (111) (121AL)<br>Select an output factor by <b>+</b> and <b>-</b> $\Rightarrow$ Press <b>SET</b> $\Rightarrow$ Selected factor is entered $\Rightarrow$<br>Press <b>DISPLAY</b> $\Rightarrow$ Returns to display mode.                                                                                                                                                                                                                                             | 52     |
| Set the factor of alarm output 2. (125AL)               | Press <b>SET</b> for longer than 3 seconds $\Rightarrow$ Press <b>MODE</b> $\Rightarrow$ Press <b>RESET/SHIFT</b> $\Rightarrow$ (111) (121AL) (122AL)<br>Press <b>RESET/SHIFT</b> $\Rightarrow$ Press <b>RESET/SHIFT</b> $\Rightarrow$ Press <b>RESET/SHIFT</b> $\Rightarrow$ (123AL) (124AL) (125AL)<br>Select an factor by <b>+</b> and <b>-</b> $\Rightarrow$ Press <b>SET</b> $\Rightarrow$ Selected factor is entered $\Rightarrow$<br>Press <b>DISPLAY</b> $\Rightarrow$ Returns to display mode.                                                     | 52     |
| Set the external operation input 1 function. (251)      | Press <b>SET</b> and <b>RESET/SHIFT</b> together for longer than 3 seconds $\Rightarrow$ Press <b>MODE</b> $\Rightarrow$ (211) (221A)<br>Press <b>MODE</b> $\Rightarrow$ Press <b>MODE</b> $\Rightarrow$ Select an function by <b>+</b> and <b>-</b> $\Rightarrow$ Press <b>SET</b> $\Rightarrow$ (241P) (251)<br>Selected function is entered $\Rightarrow$ Press <b>DISPLAY</b> $\Rightarrow$ Returns to display mode.                                                                                                                                    | 63     |
| Set the external operation input 2 function. (252)      | Press <b>SET</b> and <b>RESET/SHIFT</b> together for longer than 3 seconds $\Rightarrow$ Press <b>MODE</b> $\Rightarrow$ (211) (221A)<br>Press <b>MODE</b> $\Rightarrow$ Press <b>MODE</b> $\Rightarrow$ Press <b>RESET/SHIFT</b> $\Rightarrow$ Select an function by <b>+</b> and <b>-</b> (241P) (251) (252)<br>$\Rightarrow$ Press <b>SET</b> $\Rightarrow$ Selected function is entered $\Rightarrow$ Press <b>DISPLAY</b> $\Rightarrow$ Returns to display mode.                                                                                       | 63     |
| Set the time interval of demand current. (132)          | Press <b>SET</b> for longer than 3 seconds $\Rightarrow$ Press <b>MODE</b> $\Rightarrow$ Press <b>MODE</b> $\Rightarrow$ Press <b>RESET/SHIFT</b> (111) (121AL) (131H)<br>$\Rightarrow$ Select an time interval by <b>+</b> and <b>-</b> $\Rightarrow$ Press <b>SET</b> $\Rightarrow$ (132)<br>Selected time interval is entered $\Rightarrow$ Press <b>DISPLAY</b> $\Rightarrow$ Returns to display mode.                                                                                                                                                  | 53, 54 |
| Set the time interval of demand active power. (134)     | Press <b>SET</b> for longer than 3 seconds $\Rightarrow$ Press <b>MODE</b> $\Rightarrow$ Press <b>MODE</b> $\Rightarrow$ Press <b>RESET/SHIFT</b> (111) (121AL) (131H)<br>$\Rightarrow$ Press <b>RESET/SHIFT</b> $\Rightarrow$ Press <b>RESET/SHIFT</b> $\Rightarrow$ Select an time interval by <b>+</b> and <b>-</b> (132) (133H) (134)<br>$\Rightarrow$ Press <b>SET</b> $\Rightarrow$ Selected time interval is entered $\Rightarrow$ Press <b>DISPLAY</b> $\Rightarrow$ Returns to display mode.                                                       | 53, 54 |
| Set the operation method of demand active power. (135)  | Press <b>SET</b> for longer than 3 seconds $\Rightarrow$ Press <b>MODE</b> $\Rightarrow$ Press <b>MODE</b> $\Rightarrow$ Press <b>RESET/SHIFT</b> (111) (121AL) (131H)<br>$\Rightarrow$ Press <b>RESET/SHIFT</b> $\Rightarrow$ Press <b>RESET/SHIFT</b> $\Rightarrow$ Press <b>RESET/SHIFT</b> $\Rightarrow$ (132) (133H) (134) (135)<br>Select an operation method by <b>+</b> and <b>-</b> $\Rightarrow$ Press <b>SET</b> $\Rightarrow$<br>Selected operation method is entered $\Rightarrow$ Press <b>DISPLAY</b> $\Rightarrow$ Returns to display mode. | 53, 54 |
| Set the phase wire of input circuit. (311)              | Press <b>SET</b> and <b>DISPLAY</b> together for longer than 3 seconds $\Rightarrow$ (311)<br>Select an phase wire by <b>+</b> and <b>-</b> $\Rightarrow$ Press <b>SET</b> $\Rightarrow$ Selected phase wire is entered $\Rightarrow$<br>Press <b>DISPLAY</b> $\Rightarrow$ Returns to display mode.                                                                                                                                                                                                                                                        | 66     |
| Set the input voltage (phase-voltage full scale). (312) | Press <b>SET</b> and <b>DISPLAY</b> together for longer than 3 seconds $\Rightarrow$ Press <b>RESET/SHIFT</b> $\Rightarrow$ (311) (312)<br>Select an input voltage (In case of 1 $\phi$ 3W, it is phase-voltage full scale) by <b>+</b> and <b>-</b><br>$\Rightarrow$ Press <b>SET</b> $\Rightarrow$ Selected input voltage is entered $\Rightarrow$ Press <b>DISPLAY</b> $\Rightarrow$ Returns to display mode.                                                                                                                                            | 66     |

(2) A combination except a display pattern.

Each parenthesized number shows a setting number and this number is displayed on the setting screen.

| Items                                                    | Setting and operation procedures                                                                                                                                                                                                                                                                                                                                                                                                                                                                     | Page  |
|----------------------------------------------------------|------------------------------------------------------------------------------------------------------------------------------------------------------------------------------------------------------------------------------------------------------------------------------------------------------------------------------------------------------------------------------------------------------------------------------------------------------------------------------------------------------|-------|
| Set the display factor of main monitor.<br>(112)         | Press <b>SET</b> for longer than 3 seconds → Press <b>RESET/SHIFT</b> →<br>(111) (112)<br>Select an display factor by <b>+</b> and <b>-</b> → Press <b>SET</b> →<br>Selected display factor is entered → Press <b>DISPLAY</b> → Returns to display mode.                                                                                                                                                                                                                                             | 47~51 |
| Set the display factor of sub-monitor (left).<br>(113)   | Press <b>SET</b> for longer than 3 seconds → Press <b>RESET/SHIFT</b> → Press <b>RESET/SHIFT</b> →<br>(111) (112) (113)<br>Select an display factor by <b>+</b> and <b>-</b> → Press <b>SET</b> →<br>Selected display factor is entered → Press <b>DISPLAY</b> → Returns to display mode.                                                                                                                                                                                                            | 47~51 |
| Set the display factor of sub-monitor (center).<br>(114) | Press <b>SET</b> for longer than 3 seconds → Press <b>RESET/SHIFT</b> → Press <b>RESET/SHIFT</b> →<br>(111) (112) (113)<br>Press <b>RESET/SHIFT</b> → Select an display factor by <b>+</b> and <b>-</b> → Press <b>SET</b> →<br>(114)<br>Selected display factor is entered → Press <b>DISPLAY</b> → Returns to display mode.                                                                                                                                                                        | 47~51 |
| Set the display factor of sub-monitor (right).<br>(115)  | Press <b>SET</b> for longer than 3 seconds → Press <b>RESET/SHIFT</b> → Press <b>RESET/SHIFT</b> →<br>(111) (112) (113)<br>Press <b>RESET/SHIFT</b> → Press <b>RESET/SHIFT</b> → Select an display factor by <b>+</b> and <b>-</b> →<br>(114) (115)<br>Press <b>SET</b> → Selected display factor is entered → Press <b>DISPLAY</b> → Returns to display mode.                                                                                                                                       | 47~51 |
| Set the display factor of bar graph.<br>(116)            | Press <b>SET</b> for longer than 3 seconds → Press <b>RESET/SHIFT</b> → Press <b>RESET/SHIFT</b> →<br>(111) (112) (113)<br>Press <b>RESET/SHIFT</b> → Press <b>RESET/SHIFT</b> → Press <b>RESET/SHIFT</b> →<br>(114) (115) (116)<br>Select an display factor by <b>+</b> and <b>-</b> (If a sub-monitor is selected, an underbar will be displayed on the bottom of a digital display.) →<br>Press <b>SET</b> → Selected display factor is entered → Press <b>DISPLAY</b> → Returns to display mode. | 47~51 |

(3) Setting of active power polarity and measurement range.

Each parenthesized number shows a setting number and this number is displayed on the setting screen.

| Items                                                  | Setting and operation procedures                                                                                                                                                                                                                                                                                                                                                                                                                                                                                                         | Page  |
|--------------------------------------------------------|------------------------------------------------------------------------------------------------------------------------------------------------------------------------------------------------------------------------------------------------------------------------------------------------------------------------------------------------------------------------------------------------------------------------------------------------------------------------------------------------------------------------------------------|-------|
| Setting of measurement range of active power.<br>(215) | Press <b>SET</b> and <b>RESET/SHIFT</b> together for longer than 3 seconds → Press <b>RESET/SHIFT</b> →<br>(211) (212)<br>Press <b>RESET/SHIFT</b> → Press <b>RESET/SHIFT</b> →<br>(213) (214)<br>Select an one-side(P)/both-side(-) deflection by <b>+</b> and <b>-</b> → Press <b>SET</b> →<br>Selected deflection is entered → Press <b>RESET/SHIFT</b> →<br>(215)<br>Select a measuring range by <b>+</b> and <b>-</b> → Press <b>SET</b> →<br>Selected measuring range is entered → Press <b>DISPLAY</b> → Returns to display mode. | 58~60 |

(4) Setting of reactive power measurement range.

Each parenthesized number shows a setting number and this number is displayed on the setting screen.

| Items                                                    | Setting and operation procedures                                                                                                                                                                                                                                                                                                                                                                                                    | Page  |
|----------------------------------------------------------|-------------------------------------------------------------------------------------------------------------------------------------------------------------------------------------------------------------------------------------------------------------------------------------------------------------------------------------------------------------------------------------------------------------------------------------|-------|
| Setting of measurement range of reactive power.<br>(216) | Press <b>SET</b> and <b>RESET/SHIFT</b> together for longer than 3 seconds → Press <b>RESET/SHIFT</b> →<br>(211) (212)<br>Press <b>RESET/SHIFT</b> → Press <b>RESET/SHIFT</b> → Press <b>RESET/SHIFT</b> → Press <b>RESET/SHIFT</b> →<br>(213) (214) (215) (216)<br>Select a measuring range by <b>+</b> and <b>-</b> → Press <b>SET</b> →<br>Selected measuring range is entered → Press <b>DISPLAY</b> → Returns to display mode. | 58~60 |



(5) Setting of Wh (varh) output pulse unit.

Each parenthesized number shows a setting number and this number is displayed on the setting screen.

| Items                                              | Setting and operation procedures                                                                                                                                                                                                                                                                                                                                                                                         | Page |
|----------------------------------------------------|--------------------------------------------------------------------------------------------------------------------------------------------------------------------------------------------------------------------------------------------------------------------------------------------------------------------------------------------------------------------------------------------------------------------------|------|
| Set the pulse unit of pulse output 1 (Po1). (242P) | Press <b>SET</b> and <b>RESET/SHIFT</b> together for longer than 3 seconds → Press <b>MODE</b> → (211) (221A)<br>Press <b>MODE</b> → Press <b>RESET/SHIFT</b> → Select a output pulse unit by <b>+</b> and <b>-</b> → (241P) (242P)<br>Press <b>SET</b> → Selected output pulse unit is entered → Press <b>DISPLAY</b> → Returns to display mode.                                                                        | 62   |
| Set the pulse unit of pulse output 2 (Po2). (244P) | Press <b>SET</b> and <b>RESET/SHIFT</b> together for longer than 3 seconds → Press <b>MODE</b> → (211) (221A)<br>Press <b>MODE</b> → Press <b>RESET/SHIFT</b> → Press <b>RESET/SHIFT</b> → Press <b>RESET/SHIFT</b> → (241P) (242P) (243P) (244P)<br>Select a output pulse unit by <b>+</b> and <b>-</b> → Press <b>SET</b> →<br>Selected output pulse unit is entered → Press <b>DISPLAY</b> → Returns to display mode. | 62   |

(6) Setting of active power-factor and frequency measurement range

Each parenthesized number shows a setting number and this number is displayed on the setting screen.

| Items                                                   | Setting and operation procedures                                                                                                                                                                                                                                                                                                                                                                                                                                                                | Page  |
|---------------------------------------------------------|-------------------------------------------------------------------------------------------------------------------------------------------------------------------------------------------------------------------------------------------------------------------------------------------------------------------------------------------------------------------------------------------------------------------------------------------------------------------------------------------------|-------|
| Set the measurement range of active power-factor. (217) | Press <b>SET</b> and <b>RESET/SHIFT</b> together for longer than 3 seconds → Press <b>RESET/SHIFT</b> → (211) (212)<br>Press <b>RESET/SHIFT</b> → Press <b>RESET/SHIFT</b> → Press <b>RESET/SHIFT</b> → Press <b>RESET/SHIFT</b> → (213) (214) (215) (216)<br>Press <b>RESET/SHIFT</b> → Select a measuring range by <b>+</b> and <b>-</b> → Press <b>SET</b> → (217)<br>Selected measuring range is entered → Press <b>DISPLAY</b> → Returns to display mode.                                  | 58~60 |
| Set the measurement range of frequency. (218)           | Press <b>SET</b> and <b>RESET/SHIFT</b> together for longer than 3 seconds → Press <b>RESET/SHIFT</b> → (211) (212)<br>Press <b>RESET/SHIFT</b> → Press <b>RESET/SHIFT</b> → Press <b>RESET/SHIFT</b> → Press <b>RESET/SHIFT</b> → (213) (214) (215) (216)<br>Press <b>RESET/SHIFT</b> → Press <b>RESET/SHIFT</b> → Select a measuring range by <b>+</b> and <b>-</b> → (217) (218)<br>Press <b>SET</b> → Selected measuring range is entered → Press <b>DISPLAY</b> → Returns to display mode. | 58~60 |

(7) Setting of current display intrinsic sensitivity.

Each parenthesized number shows a setting number and this number is displayed on the setting screen.

| Items                                                                      | Setting and operation procedures                                                                                                                                                                                                                                                                                                | Page  |
|----------------------------------------------------------------------------|---------------------------------------------------------------------------------------------------------------------------------------------------------------------------------------------------------------------------------------------------------------------------------------------------------------------------------|-------|
| Set the display sensitivity (% of a display to an input) of current. (213) | Press <b>SET</b> and <b>RESET/SHIFT</b> together for longer than 3 seconds → Press <b>RESET/SHIFT</b> → (211) (212)<br>Press <b>RESET/SHIFT</b> → Select a display sensitivity by <b>+</b> and <b>-</b> → Press <b>SET</b> → (213)<br>Selected display sensitivity is entered → Press <b>DISPLAY</b> → Returns to display mode. | 58~60 |

(8) Setting of analog output.

Each parenthesized number shows a setting number and this number is displayed on the setting screen.

| Items                                                                                                                | Setting and operation procedures                                                                                                                                                                                                                                                                                                                                                                                                                                                                                                                        | Page          |
|----------------------------------------------------------------------------------------------------------------------|---------------------------------------------------------------------------------------------------------------------------------------------------------------------------------------------------------------------------------------------------------------------------------------------------------------------------------------------------------------------------------------------------------------------------------------------------------------------------------------------------------------------------------------------------------|---------------|
| <p>Set the analog output sensitivity (% of an output to an input) of current. (225A)</p>                             | <p>Press <b>SET</b> and <b>RESET/SHIFT</b> together for longer than 3 seconds ➡ Press <b>MODE</b> ➡ (211) (221A)</p> <p>Press <b>RESET/SHIFT</b> ➡ Press <b>RESET/SHIFT</b> ➡ Press <b>RESET/SHIFT</b> ➡ Press <b>RESET/SHIFT</b> ➡ (222A) (223A) (224A) (225A)</p> <p>Select a output sensitivity by <b>+</b> and <b>-</b> ➡ Press <b>SET</b> ➡</p> <p>Selected output sensitivity is entered ➡ Press <b>DISPLAY</b> ➡ Returns to display mode.</p>                                                                                                    | <p>61, 62</p> |
| <p>Set the analog output sensitivity (% of an output to an input) of active power. (226A)</p>                        | <p>Press <b>SET</b> and <b>RESET/SHIFT</b> together for longer than 3 seconds ➡ Press <b>MODE</b> ➡ (211) (221A)</p> <p>Press <b>RESET/SHIFT</b> ➡ Press <b>RESET/SHIFT</b> ➡ Press <b>RESET/SHIFT</b> ➡ Press <b>RESET/SHIFT</b> ➡ (222A) (223A) (224A) (225A)</p> <p>Press <b>RESET/SHIFT</b> ➡ Select a output sensitivity by <b>+</b> and <b>-</b> ➡ Press <b>SET</b> ➡ (226A)</p> <p>Selected output sensitivity is entered ➡ Press <b>DISPLAY</b> ➡ Returns to display mode.</p>                                                                  | <p>61, 62</p> |
| <p>Set the analog output sensitivity (% of an output to an input) of reactive power. (227A)</p>                      | <p>Press <b>SET</b> and <b>RESET/SHIFT</b> together for longer than 3 seconds ➡ Press <b>MODE</b> ➡ (211) (221A)</p> <p>Press <b>RESET/SHIFT</b> ➡ Press <b>RESET/SHIFT</b> ➡ Press <b>RESET/SHIFT</b> ➡ Press <b>RESET/SHIFT</b> ➡ (222A) (223A) (224A) (225A)</p> <p>Press <b>RESET/SHIFT</b> ➡ Press <b>RESET/SHIFT</b> ➡ Select a output sensitivity by <b>+</b> and <b>-</b> ➡ (226A) (227A)</p> <p>Press <b>SET</b> ➡ Selected output sensitivity is entered ➡ Press <b>DISPLAY</b> ➡ Returns to display mode.</p>                                | <p>61, 62</p> |
| <p>Set the output cut function at the case in minute input (0.5% or less). (At the case of analog output) (228A)</p> | <p>Press <b>SET</b> and <b>RESET/SHIFT</b> together for longer than 3 seconds ➡ Press <b>MODE</b> ➡ (211) (221A)</p> <p>Press <b>RESET/SHIFT</b> ➡ Press <b>RESET/SHIFT</b> ➡ Press <b>RESET/SHIFT</b> ➡ Press <b>RESET/SHIFT</b> ➡ (222A) (223A) (224A) (225A)</p> <p>Press <b>RESET/SHIFT</b> ➡ Press <b>RESET/SHIFT</b> ➡ Press <b>RESET/SHIFT</b> ➡ (226A) (227A) (228A)</p> <p>Select a low Input cut ON/OFF by <b>+</b> and <b>-</b> ➡ Press <b>SET</b> ➡</p> <p>Selected action is entered ➡ Press <b>DISPLAY</b> ➡ Returns to display mode.</p> | <p>61, 62</p> |

## (9) Setting of alarm output.

Each parenthesized number shows a setting number and this number is displayed on the setting screen.

| Items                                                 | Setting and operation procedures                                                                                                                                                                                                                                                                                                                                                                                                                                                                                                                 | Page |
|-------------------------------------------------------|--------------------------------------------------------------------------------------------------------------------------------------------------------------------------------------------------------------------------------------------------------------------------------------------------------------------------------------------------------------------------------------------------------------------------------------------------------------------------------------------------------------------------------------------------|------|
| Set the return method of alarm output 1. (122AL)      | <p>Press <b>SET</b> for longer than 3 seconds → Press <b>MODE</b> → Press <b>RESET/SHIFT</b> →<br/>           (111) (121AL) (122AL)</p> <p>Select a return method by <b>+</b> and <b>-</b> → Press <b>SET</b> →</p> <p>The selected return method is entered → Press <b>DISPLAY</b> → Returns to display mode.</p>                                                                                                                                                                                                                               | 52   |
| Set the contact delay time of alarm output 1. (123AL) | <p>Press <b>SET</b> for longer than 3 seconds → Press <b>MODE</b> → Press <b>RESET/SHIFT</b> →<br/>           (111) (121AL) (122AL)</p> <p>Press <b>RESET/SHIFT</b> → Select a contact delay time by <b>+</b> and <b>-</b> → Press <b>SET</b> →<br/>           (123AL)</p> <p>The selected contact delay time is entered → Press <b>DISPLAY</b> → Returns to display mode.</p>                                                                                                                                                                   | 52   |
| Set the return method of alarm output 2. (126AL)      | <p>Press <b>SET</b> for longer than 3 seconds → Press <b>MODE</b> → Press <b>RESET/SHIFT</b> →<br/>           (111) (121AL) (122AL)</p> <p>Press <b>RESET/SHIFT</b> → Press <b>RESET/SHIFT</b> → Press <b>RESET/SHIFT</b> → Press <b>RESET/SHIFT</b> →<br/>           (123AL) (124AL) (125AL) (126AL)</p> <p>Select a return method by <b>+</b> and <b>-</b> → Press <b>SET</b> → The selected return method is entered<br/>           → Press <b>DISPLAY</b> → Returns to display mode.</p>                                                     | 52   |
| Set the contact delay time of alarm output 2. (127AL) | <p>Press <b>SET</b> for longer than 3 seconds → Press <b>MODE</b> → Press <b>RESET/SHIFT</b> →<br/>           (111) (121AL) (122AL)</p> <p>Press <b>RESET/SHIFT</b> → Press <b>RESET/SHIFT</b> → Press <b>RESET/SHIFT</b> → Press <b>RESET/SHIFT</b> →<br/>           (123AL) (124AL) (125AL) (126AL)</p> <p>Press <b>RESET/SHIFT</b> → Select a contact delay time by <b>+</b> and <b>-</b> → Press <b>SET</b> →<br/>           (127AL)</p> <p>The selected contact delay time is entered → Press <b>DISPLAY</b> → Returns to display mode.</p> | 52   |

## (10) Demand measurement (current, active power) setting.

Each parenthesized number shows a setting number and this number is displayed on the setting screen.

| Items                                                       | Setting and operation procedures                                                                                                                                                                                                                                                                                                                                                                                                                                                                                            | Page   |
|-------------------------------------------------------------|-----------------------------------------------------------------------------------------------------------------------------------------------------------------------------------------------------------------------------------------------------------------------------------------------------------------------------------------------------------------------------------------------------------------------------------------------------------------------------------------------------------------------------|--------|
| Set the high-alarm value of demand current. (131H)          | <p>Press <b>SET</b> for longer than 3 seconds → Press <b>MODE</b> → Press <b>MODE</b> →<br/>           (111) (121AL) (131H)</p> <p>Select a high-alarm value by <b>+</b> and <b>-</b> → Press <b>SET</b> →</p> <p>Selected high-alarm value is entered → Press <b>DISPLAY</b> → Returns to display mode.</p>                                                                                                                                                                                                                | 53, 54 |
| Set the high-alarm value of demand active power. (133H)     | <p>Press <b>SET</b> for longer than 3 seconds → Press <b>MODE</b> → Press <b>MODE</b> → Press <b>RESET/SHIFT</b> →<br/>           (111) (121AL) (131H)</p> <p>→ Press <b>RESET/SHIFT</b> → Select a high-alarm value by <b>+</b> and <b>-</b> → Press <b>SET</b> →<br/>           (132) (133H)</p> <p>Selected high-alarm value is entered → Press <b>DISPLAY</b> → Returns to display mode.</p>                                                                                                                            | 53, 54 |
| Set the operation method of power-factor measurement. (136) | <p>Press <b>SET</b> for longer than 3 seconds → Press <b>MODE</b> → Press <b>MODE</b> → Press <b>RESET/SHIFT</b> →<br/>           (111) (121AL) (131H)</p> <p>→ Press <b>RESET/SHIFT</b> → Press <b>RESET/SHIFT</b> → Press <b>RESET/SHIFT</b> → Press <b>RESET/SHIFT</b> →<br/>           (132) (133H) (134) (135)</p> <p>→ Select a operation method by <b>+</b> and <b>-</b> → Press <b>SET</b> →<br/>           (136)</p> <p>Selected operation method is entered → Press <b>DISPLAY</b> → Returns to display mode.</p> | 53, 54 |

## (11) Harmonic measurement setting

Each parenthesized number shows a setting number and this number is displayed on the setting screen.

| Items                                                              | Setting and operation procedures                                                                                                                                                                                                                                                                                                                                                                                                                                                                                                                 | Page   |
|--------------------------------------------------------------------|--------------------------------------------------------------------------------------------------------------------------------------------------------------------------------------------------------------------------------------------------------------------------------------------------------------------------------------------------------------------------------------------------------------------------------------------------------------------------------------------------------------------------------------------------|--------|
| Set the high-alarm value of current distortion factor. (141H)      | Press <b>SET</b> for longer than 3 seconds → Press <b>MODE</b> → Press <b>MODE</b> → Press <b>MODE</b> →<br>(111) (121AL) (131H) (141H)<br>Select a high-alarm value by <b>+</b> and <b>-</b> → Press <b>SET</b> →<br>Selected high-alarm value is entered → Press <b>DISPLAY</b> → Returns to display mode.                                                                                                                                                                                                                                     | 54, 55 |
| Set the high-alarm value of 5th current conversion content. (142H) | Press <b>SET</b> for longer than 3 seconds → Press <b>MODE</b> → Press <b>MODE</b> → Press <b>MODE</b> →<br>(111) (121AL) (131H) (141H)<br>Press <b>RESET/SHIFT</b> → Select a high-alarm value by <b>+</b> and <b>-</b> → Press <b>SET</b> →<br>(142H)<br>Selected high-alarm value is entered → Press <b>DISPLAY</b> → Returns to display mode.                                                                                                                                                                                                | 54, 55 |
| Set the order of n-th current content. (143)                       | Press <b>SET</b> for longer than 3 seconds → Press <b>MODE</b> → Press <b>MODE</b> → Press <b>MODE</b> →<br>(111) (121AL) (131H) (141H)<br>Press <b>RESET/SHIFT</b> → Press <b>RESET/SHIFT</b> → Select a order by <b>+</b> and <b>-</b> → Press <b>SET</b> →<br>(142H) (143)<br>→ Selected order is entered → Press <b>DISPLAY</b> → Returns to display mode.                                                                                                                                                                                   | 54, 55 |
| Set the high-alarm value of n-th current content. (144H)           | Press <b>SET</b> for longer than 3 seconds → Press <b>MODE</b> → Press <b>MODE</b> → Press <b>MODE</b> →<br>(111) (121AL) (131H) (141H)<br>Press <b>RESET/SHIFT</b> → Press <b>RESET/SHIFT</b> → Press <b>RESET/SHIFT</b> →<br>(142H) (143) (144H)<br>Select a high-alarm value by <b>+</b> and <b>-</b> → Press <b>SET</b> →<br>Selected high-alarm value is entered → Press <b>DISPLAY</b> → Returns to display mode.                                                                                                                          | 54, 55 |
| Set the high-alarm value of voltage distortion factor. (145H)      | Press <b>SET</b> for longer than 3 seconds → Press <b>MODE</b> → Press <b>MODE</b> → Press <b>MODE</b> →<br>(111) (121AL) (131H) (141H)<br>Press <b>RESET/SHIFT</b> → Press <b>RESET/SHIFT</b> → Press <b>RESET/SHIFT</b> → Press <b>RESET/SHIFT</b> →<br>(142H) (143) (144H) (145H)<br>Select a high-alarm value by <b>+</b> and <b>-</b> → Press <b>SET</b> →<br>Selected high-alarm value is entered → Press <b>DISPLAY</b> → Returns to display mode.                                                                                        | 54, 55 |
| Set the high-alarm value of voltage 5th conversion content. (146H) | Press <b>SET</b> for longer than 3 seconds → Press <b>MODE</b> → Press <b>MODE</b> → Press <b>MODE</b> →<br>(111) (121AL) (131H) (141H)<br>Press <b>RESET/SHIFT</b> → Press <b>RESET/SHIFT</b> → Press <b>RESET/SHIFT</b> → Press <b>RESET/SHIFT</b> →<br>(142H) (143) (144H) (145H)<br>Press <b>RESET/SHIFT</b> → Select a high-alarm value by <b>+</b> and <b>-</b> → Press <b>SET</b> →<br>(146H)<br>Selected high-alarm value is entered → Press <b>DISPLAY</b> → Returns to display mode.                                                   | 54, 55 |
| Set the order of n-th voltage content. (147)                       | Press <b>SET</b> for longer than 3 seconds → Press <b>MODE</b> → Press <b>MODE</b> → Press <b>MODE</b> →<br>(111) (121AL) (131H) (141H)<br>Press <b>RESET/SHIFT</b> → Press <b>RESET/SHIFT</b> → Press <b>RESET/SHIFT</b> → Press <b>RESET/SHIFT</b> →<br>(142H) (143) (144H) (145H)<br>Press <b>RESET/SHIFT</b> → Press <b>RESET/SHIFT</b> → Select a order by <b>+</b> and <b>-</b> → Press <b>SET</b> →<br>(146H) (147)<br>→ Selected order is entered → Press <b>DISPLAY</b> → Returns to display mode.                                      | 54, 55 |
| Set the high-alarm value of n-th voltage content. (148H)           | Press <b>SET</b> for longer than 3 seconds → Press <b>MODE</b> → Press <b>MODE</b> → Press <b>MODE</b> →<br>(111) (121AL) (131H) (141H)<br>Press <b>RESET/SHIFT</b> → Press <b>RESET/SHIFT</b> → Press <b>RESET/SHIFT</b> → Press <b>RESET/SHIFT</b> →<br>(142H) (143) (144H) (145H)<br>Press <b>RESET/SHIFT</b> → Press <b>RESET/SHIFT</b> → Press <b>RESET/SHIFT</b> →<br>(146H) (147) (148H)<br>Select a factor by <b>+</b> and <b>-</b> → Press <b>SET</b> → Selected factor is entered →<br>Press <b>DISPLAY</b> → Returns to display mode. | 54, 55 |

| Items                                                             | Setting and operation procedures                                                                                                                                                                                                                                                                                                                                                                                                                                                                                                                                                                                                    | Page   |
|-------------------------------------------------------------------|-------------------------------------------------------------------------------------------------------------------------------------------------------------------------------------------------------------------------------------------------------------------------------------------------------------------------------------------------------------------------------------------------------------------------------------------------------------------------------------------------------------------------------------------------------------------------------------------------------------------------------------|--------|
| Set the detected characteristics of 5th conversion content. (149) | Press <b>SET</b> for longer than 3 seconds → Press <b>MODE</b> → Press <b>MODE</b> → Press <b>MODE</b> →<br>(111) (121AL) (131H) (141H)<br>Press <b>RESET/SHIFT</b> → Press <b>RESET/SHIFT</b> → Press <b>RESET/SHIFT</b> → Press <b>RESET/SHIFT</b> →<br>(142H) (143) (144H) (145H)<br>Press <b>RESET/SHIFT</b> → Press <b>RESET/SHIFT</b> → Press <b>RESET/SHIFT</b> → Press <b>RESET/SHIFT</b> →<br>(146H) (147) (148H) (149)<br>Select a detected characteristics by <b>+</b> and <b>-</b> → Press <b>SET</b> →<br>Selected detected characteristics is entered → Press <b>DISPLAY</b> → Returns to display mode.               | 54, 55 |
| Set the average time interval. (14A)                              | Press <b>SET</b> for longer than 3 seconds → Press <b>MODE</b> → Press <b>MODE</b> → Press <b>MODE</b> →<br>(111) (121AL) (131H) (141H)<br>Press <b>RESET/SHIFT</b> → Press <b>RESET/SHIFT</b> → Press <b>RESET/SHIFT</b> → Press <b>RESET/SHIFT</b> →<br>(142H) (143) (144H) (145H)<br>Press <b>RESET/SHIFT</b> → Press <b>RESET/SHIFT</b> → Press <b>RESET/SHIFT</b> → Press <b>RESET/SHIFT</b> →<br>(146H) (147) (148H) (149)<br>Press <b>RESET/SHIFT</b> → Select a time interval by <b>+</b> and <b>-</b> → Press <b>SET</b> →<br>(14A)<br>Selected time interval is entered → Press <b>DISPLAY</b> → Returns to display mode. | 54, 55 |

## (12) Instant measurement setting

Each parenthesized number shows a setting number and this number is displayed on the setting screen.

| Items                                               | Setting and operation procedures                                                                                                                                                                                                                                                                                                                                           | Page |
|-----------------------------------------------------|----------------------------------------------------------------------------------------------------------------------------------------------------------------------------------------------------------------------------------------------------------------------------------------------------------------------------------------------------------------------------|------|
| Set the high-alarm value of instant voltage. (151H) | Press <b>SET</b> for longer than 3 seconds → Press <b>MODE</b> → Press <b>MODE</b> → Press <b>MODE</b> →<br>(111) (121AL) (131H) (141H)<br>Press <b>MODE</b> → Select a high-alarm value by <b>+</b> and <b>-</b> → Press <b>SET</b> →<br>(151H)<br>Selected high-alarm value is entered → Press <b>DISPLAY</b> → Returns to display mode.                                 | 55   |
| Set the low-alarm value of instant voltage. (152L)  | Press <b>SET</b> for longer than 3 seconds → Press <b>MODE</b> → Press <b>MODE</b> → Press <b>MODE</b> →<br>(111) (121AL) (131H) (141H)<br>Press <b>MODE</b> → Press <b>RESET/SHIFT</b> → Select a low-alarm value by <b>+</b> and <b>-</b> →<br>(151H) (152L)<br>Press <b>SET</b> → Selected low-alarm value is entered → Press <b>DISPLAY</b> → Returns to display mode. | 55   |

## (13) Current-leakage measurement setting

Each parenthesized number shows a setting number and this number is displayed on the setting screen.

| Items                                                             | Setting and operation procedures                                                                                                                                                                                                                                                                                                                                                                       | Page |
|-------------------------------------------------------------------|--------------------------------------------------------------------------------------------------------------------------------------------------------------------------------------------------------------------------------------------------------------------------------------------------------------------------------------------------------------------------------------------------------|------|
| Set the rated sensitivity current value of current leakage. (161) | Press <b>SET</b> for longer than 3 seconds → Press <b>MODE</b> → Press <b>MODE</b> → Press <b>MODE</b> →<br>(111) (121AL) (131H) (141H)<br>Press <b>MODE</b> → Press <b>MODE</b> → Select a rated sensitivity current by <b>+</b> and <b>-</b> →<br>(151H) (161)<br>Press <b>SET</b> → Selected rated sensitivity current is entered → Press <b>DISPLAY</b> →<br>Returns to display mode.              | 56   |
| Set the detected factor of current leakage. (162)                 | Press <b>SET</b> for longer than 3 seconds → Press <b>MODE</b> → Press <b>MODE</b> → Press <b>MODE</b> →<br>(111) (121AL) (131H) (141H)<br>Press <b>MODE</b> → Press <b>MODE</b> → Press <b>RESET/SHIFT</b> →<br>(151H) (161) (162)<br>Select a detected factor by <b>+</b> and <b>-</b> → Press <b>SET</b> → Selected detected factor is entered<br>→ Press <b>DISPLAY</b> → Returns to display mode. | 56   |

| Items                                                                           | Setting and operation procedures                                                                                                                                                                                                                                                                                                                                                                                                                              | Page |
|---------------------------------------------------------------------------------|---------------------------------------------------------------------------------------------------------------------------------------------------------------------------------------------------------------------------------------------------------------------------------------------------------------------------------------------------------------------------------------------------------------------------------------------------------------|------|
| Set the leakage detected circuit configuration.<br>(by 3-phase 3-wire)<br>(163) | Press <b>SET</b> for longer than 3 seconds → Press <b>MODE</b> → Press <b>MODE</b> → Press <b>MODE</b> →<br>(111) (121AL) (131H) (141H)<br>Press <b>MODE</b> → Press <b>MODE</b> → Press <b>RESET/SHIFT</b> → Press <b>RESET/SHIFT</b> →<br>(151H) (161) (162) (163)<br>Select a circuit by <b>+</b> and <b>-</b> → Press <b>SET</b> → Selected circuit is entered →<br>Press <b>DISPLAY</b> → Returns to display mode.                                       | 56   |
| Set the ZCT used by current-leakage measurement.<br>(164)                       | Press <b>SET</b> for longer than 3 seconds → Press <b>MODE</b> → Press <b>MODE</b> → Press <b>MODE</b> →<br>(111) (121AL) (131H) (141H)<br>Press <b>MODE</b> → Press <b>MODE</b> → Press <b>RESET/SHIFT</b> → Press <b>RESET/SHIFT</b> →<br>(151H) (161) (162) (163)<br>Press <b>RESET/SHIFT</b> → Select a ZCT type by <b>+</b> and <b>-</b> → Press <b>SET</b> →<br>(164)<br>Selected ZCT type is entered → Press <b>DISPLAY</b> → Returns to display mode. | 56   |

(14) Backlight setting

Each parenthesized number shows a setting number and this number is displayed on the setting screen.

| Items                                     | Setting and operation procedures                                                                                                                                                                                                                                                                                                                                                                                                 | Page |
|-------------------------------------------|----------------------------------------------------------------------------------------------------------------------------------------------------------------------------------------------------------------------------------------------------------------------------------------------------------------------------------------------------------------------------------------------------------------------------------|------|
| Set the action of backlight.<br>(171)     | Press <b>SET</b> for longer than 3 seconds → Press <b>MODE</b> → Press <b>MODE</b> → Press <b>MODE</b> →<br>(111) (121AL) (131H) (141H)<br>Press <b>MODE</b> → Press <b>MODE</b> → Press <b>MODE</b> → Select a backlight action by <b>+</b> and <b>-</b> →<br>(151H) (161) (171)<br>Press <b>SET</b> → Selected backlight action is entered → Press <b>DISPLAY</b> → Returns to display mode.                                   | 57   |
| Set the brightness of backlight.<br>(172) | Press <b>SET</b> for longer than 3 seconds → Press <b>MODE</b> → Press <b>MODE</b> → Press <b>MODE</b> →<br>(111) (121AL) (131H) (141H)<br>Press <b>MODE</b> → Press <b>MODE</b> → Press <b>MODE</b> → Press <b>RESET/SHIFT</b> →<br>(151H) (161) (171) (172)<br>Select a brightness by <b>+</b> and <b>-</b> → Press <b>SET</b> →<br>Selected backlight brightness is entered → Press <b>DISPLAY</b> → Returns to display mode. | 57   |

(15) Other, measurement setting

Each parenthesized number shows a setting number and this number is displayed on the setting screen.

| Items                                                                          | Setting and operation procedures                                                                                                                                                                                                                                                                                           | Page |
|--------------------------------------------------------------------------------|----------------------------------------------------------------------------------------------------------------------------------------------------------------------------------------------------------------------------------------------------------------------------------------------------------------------------|------|
| Set the dead band of measurement display.<br>(321)                             | Press <b>SET</b> and <b>DISPLAY</b> together for longer than 3 seconds → Press <b>MODE</b> →<br>(311) (321)<br>Select of dead band value in measurement display by <b>+</b> and <b>-</b> → Press <b>SET</b> →<br>The value of dead band in display is entered → Press <b>DISPLAY</b> → Returns to display mode.            | 67   |
| Set the tidal current measurement of reactive power and power-factor.<br>(322) | Press <b>SET</b> and <b>DISPLAY</b> together for longer than 3 seconds → Press <b>MODE</b> →<br>(311) (321)<br>Press <b>RESET/SHIFT</b> → Select a tidal current measurement ON/OFF by <b>+</b> and <b>-</b> →<br>(322)<br>Press <b>SET</b> → Selected action is entered → Press <b>DISPLAY</b> → Returns to display mode. | 67   |

## 5.3 Setting in detail explanation

## 5.3.1 Setting mode 1

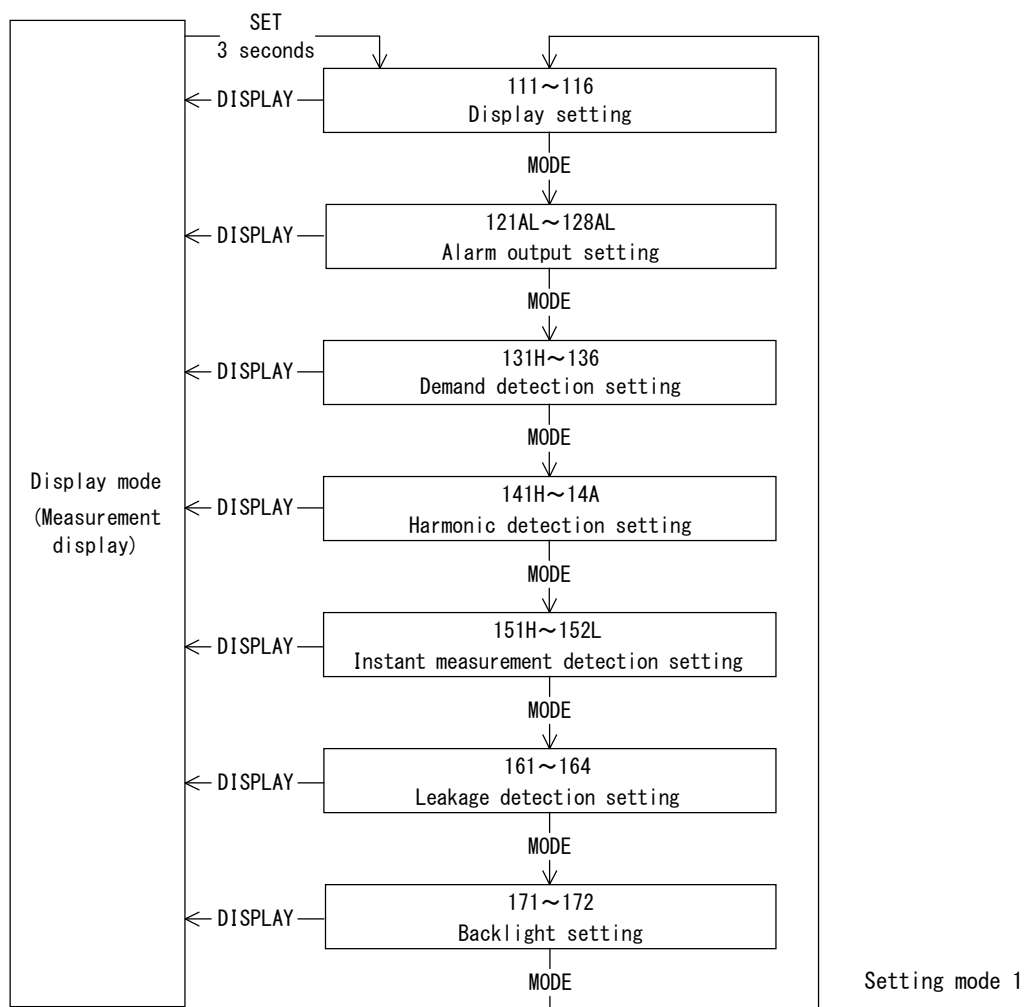

Setting mode 1 is selected by pressing **SET** switch for longer than 3 seconds.

Pushing **MODE** switch performs movement of setting item.

The present mode can be returned to the display mode by pressing **DISPLAY** switch.

< Caution >

If setting change should have been mistaken, an alarm output is not obtained correctly.

Therefore, users must not set. The setting item without the corresponding option is not displayed.

(1) 111~116 Display combination setting 【All models】

● 3-phase 3-wire (Voltage, current input) <sup>(37)</sup> <sup>(38)</sup>

| No. | Pattern No. | Main monitor | Sub-monitor (Left)     | Sub-monitor (Center) | Sub-monitor (Right) | Bar graph |
|-----|-------------|--------------|------------------------|----------------------|---------------------|-----------|
| 1   | Pattern 1   | A (Y)        | V (RY)                 | W                    | Wh                  | A (Y)     |
| 2   | Pattern 2   | A (Y)        | V (RY)                 | W                    | cos φ               | A (Y)     |
| 3   | Pattern 3   | A (Y)        | V (RY)                 | W                    | Hz                  | A (Y)     |
| 4   | Pattern 4   | DA (Y)       | A (Y)                  | V (RY)               | W                   | DA (Y)    |
| 5   | Pattern 5   | DA (Y)       | A (Y)                  | V (RY)               | Wh                  | DA (Y)    |
| 6   | Pattern 6   | DA (Y)       | V (RY)                 | W                    | cos φ               | DA (Y)    |
| 7   | Pattern 7   | W            | V (RY)                 | A (Y)                | Wh                  | W         |
| 8   | Pattern 8   | W            | V (RY)                 | A (Y)                | cos φ               | W         |
| 9   | Pattern 9   | W            | V (RY)                 | A (Y)                | Hz                  | W         |
| 10  | Pattern 10  | DW           | V (RY)                 | W                    | Wh                  | DW        |
| 11  | Pattern 11  | DW           | V (RY)                 | A (Y)                | cos φ               | DW        |
| 12  | Pattern 12  | A (Y)        | cos φ                  | W                    | Wh                  | A (Y)     |
| 13  | Pattern 13  | A (Y)        | var                    | W                    | Wh                  | A (Y)     |
| 14  | Pattern 14  | W            | cos φ                  | var                  | Wh                  | W         |
| 15  | Pattern 15  | A (Y)        | A (R)                  | A (B)                | Wh                  | A (Y)     |
| 16  | Pattern 16  | V (RY)       | V (YB)                 | V (BR)               | Hz                  | V (RY)    |
| 17  | Pattern 17  | A (R)        | Io/Igr <sup>(39)</sup> | V (RY)               | W                   | A (R)     |
| 18  | Pattern 18  | A (R)        | Io/Igr <sup>(39)</sup> | V (RY)               | Wh                  | A (R)     |

Note<sup>(37)</sup> Voltage input is pattern 16 only.

Note<sup>(38)</sup> Current input is pattern 15 only. (However, sub-monitor (right) is displayed blank.)

Note<sup>(39)</sup> Io/Igr is only with leakage measurement.

● Displays set factor (3-phase 3-wire)

|                      |                                                                                                                                                                                                                                                                                                                                 |
|----------------------|---------------------------------------------------------------------------------------------------------------------------------------------------------------------------------------------------------------------------------------------------------------------------------------------------------------------------------|
| Main monitor         | V (RY), V (YB), V (BR), A (R), A (Y), A (B), DA (R), DA (Y), DA (B), W, DW, var, cos φ, Hz, Io/Igr, Wh, -Wh, varh(LAG), varh(LEAD), -varh(LAG), -varh(LEAD), Distortion factor (A, V)                                                                                                                                           |
| Sub-monitor (Left)   | V (RY), V (YB), V (BR), A (R), A (Y), A (B), W, var, cos φ, Io/Igr                                                                                                                                                                                                                                                              |
| Sub-monitor (Center) | V (RY), V (YB), V (BR), A (R), A (Y), A (B), DA (R), DA (Y), DA (B), W, DW, var, varh(LAG), varh(LEAD), -varh(LAG), -varh(LEAD), Harmonic 5th conversion content (A, V), Harmonic nth content (A, V)                                                                                                                            |
| Sub-monitor (Right)  | V (RY), V (YB), V (BR), A (R), A (Y), A (B), DA (R), DA (Y), DA (B), W, DW, cos φ, Hz, Wh, -Wh, Fundamental-wave effective value (A, V), Harmonic 5th conversion effective value (A, V), Harmonic nth effective value (A, V)                                                                                                    |
| Bar graph            | V (RY), V (YB), V (BR), A (R), A (Y), A (B), DA (R), DA (Y), DA (B), W, DW, var, cos φ, Hz, Io/Igr, Distortion factor (A, V), Harmonic 5th conversion content (A, V), Harmonic nth content (A, V), Fundamental-wave effective value (A, V), Harmonic 5th conversion effective value (A, V), Harmonic nth effective value (A, V) |

● Phase (line) change (3-phase 3-wire) <sup>(40)</sup>

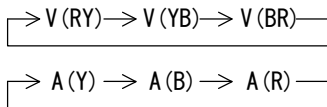

Note<sup>(40)</sup> Press **DISPLAY**, Voltage and current are replaced at the same time.

● Measurement factor change (3-phase 3-wire, Measurement display mode)

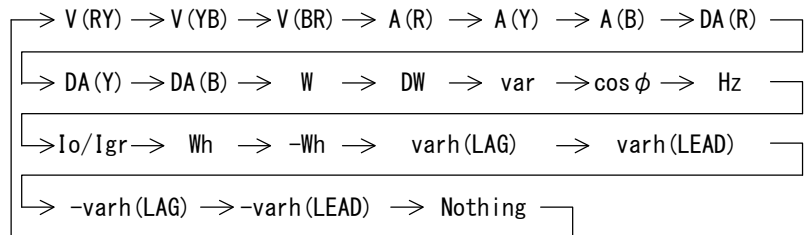

● Measurement factor change (3-phase 3-wire, Harmonic measurement display mode)

Main monitor : Distortion factor (Fixation)

Sub-monitor (Left) : Harmonic order n → 5th conversion → 1 → 3 → 4 → 5 → 7 → 9 → 11 → 13 → 15 →

Sub-monitor (Center) : Harmonic nth content (Fixation)

Sub-monitor (Right) : Harmonic nth effective value (Fixation)



● Single-phase 3-wire (Voltage, current input) <sup>(41)</sup> <sup>(42)</sup>

| No. | Pattern No. | Main monitor | Sub-monitor (Left)     | Sub-monitor (Center) | Sub-monitor (Right) | Bar graph |
|-----|-------------|--------------|------------------------|----------------------|---------------------|-----------|
| 1   | Pattern 1   | A (R)        | V (RW)                 | W                    | Wh                  | A (R)     |
| 2   | Pattern 2   | A (R)        | V (RW)                 | W                    | cos φ               | A (R)     |
| 3   | Pattern 3   | A (R)        | V (RW)                 | W                    | Hz                  | A (R)     |
| 4   | Pattern 4   | DA (R)       | A (R)                  | V (RW)               | W                   | DA (R)    |
| 5   | Pattern 5   | DA (R)       | A (R)                  | V (RW)               | Wh                  | DA (R)    |
| 6   | Pattern 6   | DA (R)       | V (RW)                 | W                    | cos φ               | DA (R)    |
| 7   | Pattern 7   | W            | V (RW)                 | A (R)                | Wh                  | W         |
| 8   | Pattern 8   | W            | V (RW)                 | A (R)                | cos φ               | W         |
| 9   | Pattern 9   | W            | V (RW)                 | A (R)                | Hz                  | W         |
| 10  | Pattern 10  | DW           | V (RW)                 | W                    | Wh                  | DW        |
| 11  | Pattern 11  | DW           | V (RW)                 | A (R)                | cos φ               | DW        |
| 12  | Pattern 12  | A (R)        | cos φ                  | W                    | Wh                  | A (R)     |
| 13  | Pattern 13  | A (R)        | var                    | W                    | Wh                  | A (R)     |
| 14  | Pattern 14  | W            | cos φ                  | var                  | Wh                  | W         |
| 15  | Pattern 15  | A (R)        | A (B)                  | A (W)                | Wh                  | A (R)     |
| 16  | Pattern 16  | V (RW)       | V (BW)                 | V (RB)               | Hz                  | V (RW)    |
| 17  | Pattern 17  | A (R)        | Io/Igr <sup>(43)</sup> | V (RW)               | W                   | A (R)     |
| 18  | Pattern 18  | A (R)        | Io/Igr <sup>(43)</sup> | V (RW)               | Wh                  | A (R)     |

Note<sup>(41)</sup> Voltage input is pattern 16 only.

Note<sup>(42)</sup> Current input is pattern 15 only. (However, sub-monitor (right) is displayed blank.)

Note<sup>(43)</sup> Io/Igr is only with leakage measurement.

● Displays set factor (Single-phase 3-wire)

|                      |                                                                                                                                                                                                                                                                                                                                 |
|----------------------|---------------------------------------------------------------------------------------------------------------------------------------------------------------------------------------------------------------------------------------------------------------------------------------------------------------------------------|
| Main monitor         | V (RW), V (BW), V (RB), A (R), A (B), A (W), DA (R), DA (B), DA (W), W, DW, var, cos φ, Hz, Io/Igr, Wh, -Wh, varh(LAG), varh(LEAD), -varh(LAG), -varh(LEAD), Distortion factor (A, V)                                                                                                                                           |
| Sub-monitor (Left)   | V (RW), V (BW), V (RB), A (R), A (B), A (W), W, var, cos φ, Io/Igr                                                                                                                                                                                                                                                              |
| Sub-monitor (Center) | V (RW), V (BW), V (RB), A (R), A (B), A (W), DA (R), DA (B), DA (W), W, DW, var, varh(LAG), varh(LEAD), -varh(LAG), -varh(LEAD), Harmonic 5th conversion content (A, V), Harmonic nth content (A, V)                                                                                                                            |
| Sub-monitor (Right)  | V (RW), V (BW), V (RB), A (R), A (B), A (W), DA (R), DA (B), DA (W), W, DW, cos φ, Hz, Wh, -Wh, Fundamental-wave effective value (A, V), Harmonic 5th conversion effective value (A, V), Harmonic nth effective value (A, V)                                                                                                    |
| Bar graph            | V (RW), V (BW), V (RB), A (R), A (B), A (W), DA (R), DA (B), DA (W), W, DW, var, cos φ, Hz, Io/Igr, Distortion factor (A, V), Harmonic 5th conversion content (A, V), Harmonic nth content (A, V), Fundamental-wave effective value (A, V), Harmonic 5th conversion effective value (A, V), Harmonic nth effective value (A, V) |

● Phase (line) change <sup>(44)</sup>  
(Single-phase 3-wire)

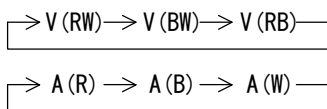

Note<sup>(44)</sup> Press **DISPLAY**. Voltage and current are replaced at the same time.

● Measurement factor change (Single-phase 3-wire, Measurement display mode)

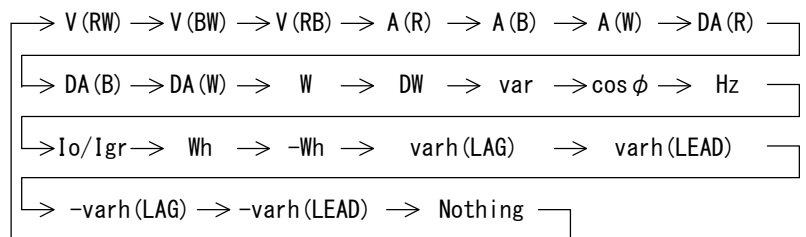

● Measurement factor change (Single-phase 3-wire, Harmonic measurement display mode)

Main monitor : Distortion factor (Fixation)

Sub-monitor (Left) : Harmonic order n → 5th conversion → 1 → 3 → 4 → 5 → 7 → 9 → 11 → 13 → 15

Sub-monitor (Center) : Harmonic nth content (Fixation)

Sub-monitor (Right) : Harmonic nth effective value (Fixation)

● Single-phase 2-wire (Voltage, current input) <sup>(45)</sup> <sup>(46)</sup>

| No. | Pattern No. | Main monitor | Sub-monitor (Left)     | Sub-monitor (Center) | Sub-monitor (Right) | Bar graph |
|-----|-------------|--------------|------------------------|----------------------|---------------------|-----------|
| 1   | Pattern 1   | A            | V                      | W                    | Wh                  | A         |
| 2   | Pattern 2   | A            | V                      | W                    | cos φ               | A         |
| 3   | Pattern 3   | A            | V                      | W                    | Hz                  | A         |
| 4   | Pattern 4   | DA           | A                      | V                    | W                   | DA        |
| 5   | Pattern 5   | DA           | A                      | V                    | Wh                  | DA        |
| 6   | Pattern 6   | DA           | V                      | W                    | cos φ               | DA        |
| 7   | Pattern 7   | W            | V                      | A                    | Wh                  | W         |
| 8   | Pattern 8   | W            | V                      | A                    | cos φ               | W         |
| 9   | Pattern 9   | W            | V                      | A                    | Hz                  | W         |
| 10  | Pattern 10  | DW           | V                      | W                    | Wh                  | DW        |
| 11  | Pattern 11  | DW           | V                      | A                    | cos φ               | DW        |
| 12  | Pattern 12  | A            | cos φ                  | W                    | Wh                  | A         |
| 13  | Pattern 13  | A            | var                    | W                    | Wh                  | A         |
| 14  | Pattern 14  | W            | cos φ                  | var                  | Wh                  | W         |
| 15  | Pattern 15  | A            | —                      | —                    | Wh                  | A         |
| 16  | Pattern 16  | V            | —                      | —                    | Hz                  | V         |
| 17  | Pattern 17  | A            | Io/Igr <sup>(47)</sup> | V                    | W                   | A         |
| 18  | Pattern 18  | A            | Io/Igr <sup>(47)</sup> | V                    | Wh                  | A         |

Note<sup>(45)</sup> Voltage input is pattern 16 only.

Note<sup>(46)</sup> Current input is pattern 15 only. (However, sub-monitor (right) is displayed blank.)

Note<sup>(47)</sup> Io/Igr is only with leakage measurement.

● Displays set factor (Single-phase 2-wire)

|                      |                                                                                                                                                                                                                                                                |
|----------------------|----------------------------------------------------------------------------------------------------------------------------------------------------------------------------------------------------------------------------------------------------------------|
| Main monitor         | V, A, DA, W, DW, var, cos φ, Hz, Io/Igr, Wh, -Wh, varh(LAG), varh(LEAD), -varh(LAG), -varh(LEAD), Distortion factor(A, V)                                                                                                                                      |
| Sub-monitor (Left)   | V, A, W, var, cos φ, Io/Igr                                                                                                                                                                                                                                    |
| Sub-monitor (Center) | V, A, DA, W, DW, var, varh(LAG), varh(LEAD), -varh(LAG), -varh(LEAD), Harmonic 5th conversion content(A, V), Harmonic nth content(A, V)                                                                                                                        |
| Sub-monitor (Right)  | V, A, DA, W, DW, cos φ, Hz, Wh, -Wh, Fundamental-wave effective value(A, V), Harmonic 5th conversion effective value(A, V), Harmonic nth effective value(A, V)                                                                                                 |
| Bar graph            | V, A, DA, W, DW, var, cos φ, Hz, Io/Igr, Distortion factor(A, V), Harmonic 5th conversion content(A, V), Harmonic nth content(A, V), Fundamental-wave effective value(A, V), Harmonic 5th conversion effective value(A, V), Harmonic nth effective value(A, V) |

● Measurement factor change (Single-phase 2-wire, Measurement display mode)

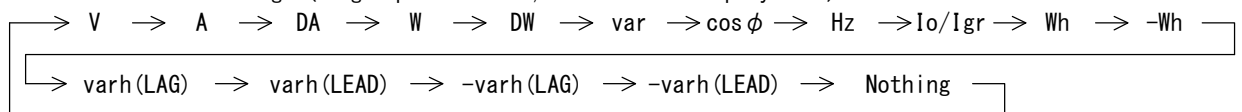

● Measurement factor change (Single-phase 2-wire, Harmonic measurement display mode)

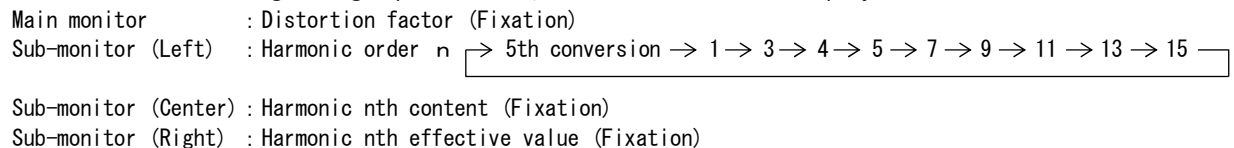

Display combination setting

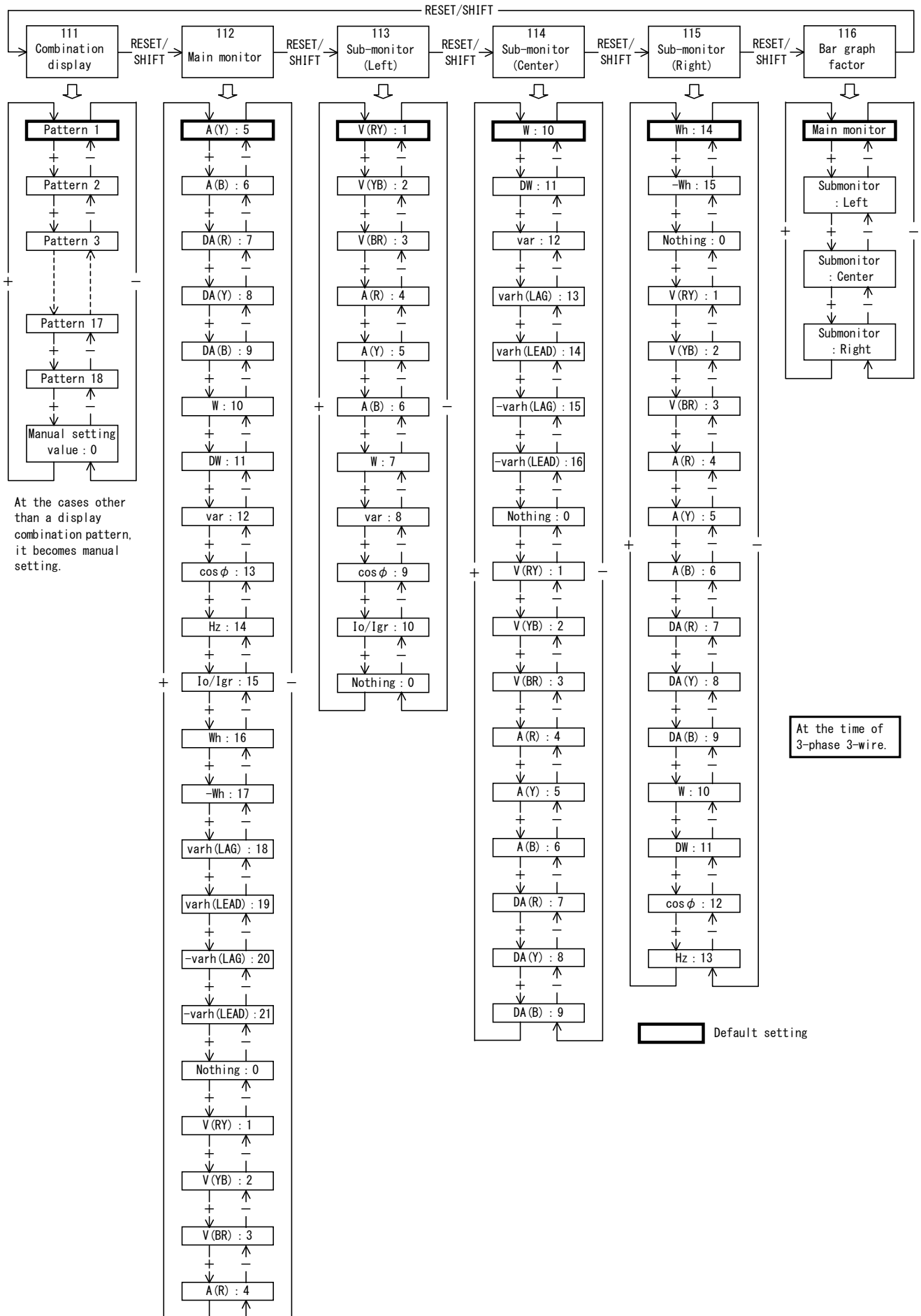

- ◆ 111 Combination display  
 Select the factors to be measured and monitored by 4 digital displays out of combination patterns.  
 Set values are updated by **SET**.

- ◆ 112~115 Main monitor, Sub-monitor (left), Sub-monitor (center), Sub-monitor (right)  
 Set these items for a display configuration other than combined patterns. Set values are updated by **SET**.

- ◆ 116 Bar graph factor  
 A factor being monitored in the main monitor is basically displayed by a bar graph. Set this item for displaying a factor being monitored on a sub-monitor by bar graph. An underbar is attached to the digital display of the setting sub-monitor.  
 Set values are updated by **SET**.

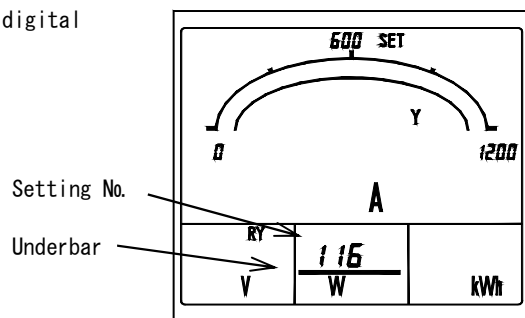
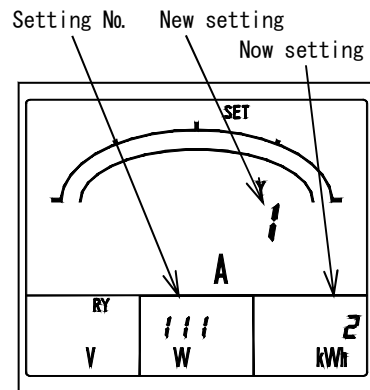

(2) 121AL~128AL Alarm output setting 【With an alarm output option】

Various setting and an output test are performed about an alarm output.

In case contact outputs 1 and 2 are alarm-output specifications, the corresponding alarm output is setting.

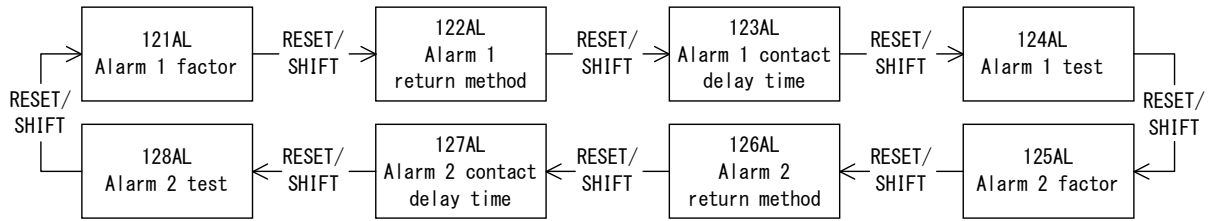

◆ 121AL Alarm 1 factor setting, 125AL Alarm 2 factor setting.

Set the output factor of alarms 1 and 2. Selection by **+** and **-**, set value is updated by **SET**.

Default value : 1 (DA : Demand current)

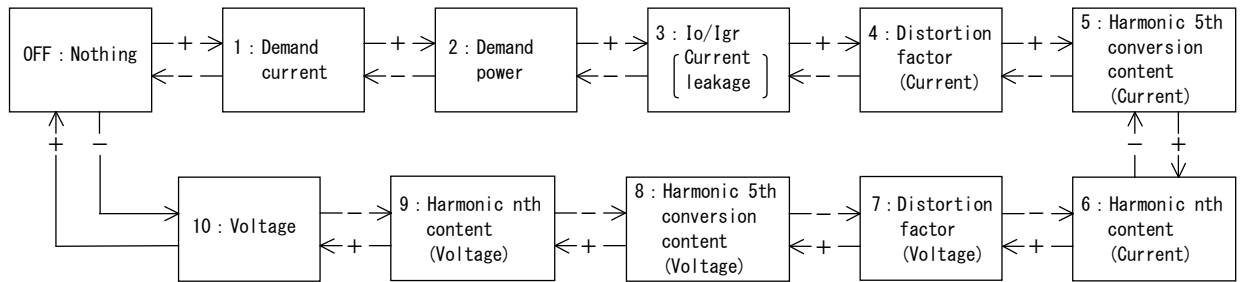

◆ 122AL Alarm 1 reset method setting, 126AL Alarm 2 reset method setting

Output action at the case of a reset of alarms 1 and 2 can be selected from AUTO (automatic reset) and HOLD (manual reset).

In "AUTO (automatic reset)", an alarm output also constitutes OFF according to a reset of an alarm. In "HOLD (manual reset)", even after an alarm reset, an output holds ON. The reset in this case (output OFF) is performed in **RESET/SHIFT**.

Selection by **+** and **-**, set value is updated by **SET**.

Default setting : AUTO (automatic reset)

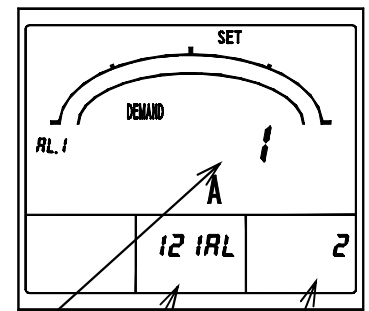

New setting Setting No. Now setting

◆ 123AL Alarm 1 contact delay time, 127AL Alarm 2 contact delay time

Set the contact delay time of alarms 1 and 2. The setting range is 0 to 300 seconds (1-second step).

Selection by **+** and **-**, set value is updated by **SET**.

Default setting : 0 second (With no contact delay)

◆ 124AL Alarm 1 test, 128AL Alarm 2 test

The output of alarms 1 and 2 is tested. While pushing **SET**, an output is ON, and if it detaches, an output switches OFF. In addition, while pushing **SET**, the test input exceeding rated sensitivity current value is applied to the zero-phase current input circuit inside a product, and if the time which is pushing **SET** exceeds the operating time (time-delay type, 0.1 second < 2 second) of a current leakage, an alarm will occur.

(In case an alarm-output factor is a current leakage (Io/Igr))  
And, test input will become OFF if **SET** is detached. Please apply rated voltage to a voltage-input terminal (between P1-P2) at this time.  
In addition, about a reset of an alarm, it becomes action united with reset method setting (automatic reset / manual reset) of each alarm output.

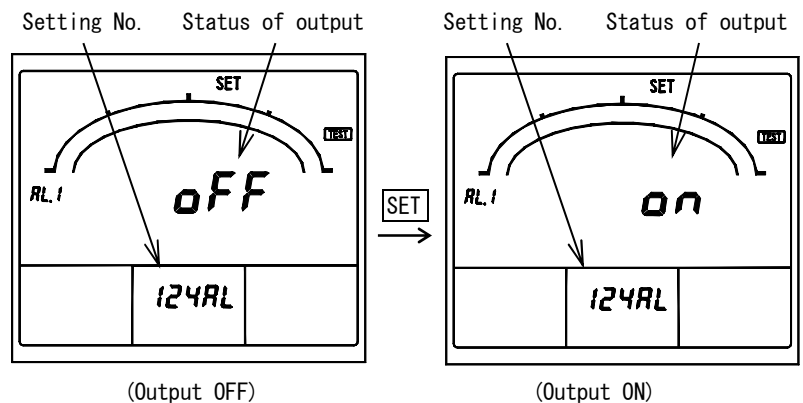

(Output OFF)

(Output ON)

Alarm 1 test

(3) 131H~136 Demand detection setting 【Except voltage input】

The following operation method is setting.

Demand current, action of demand, high-alarm value, time-interval, power-factor, demand active power.

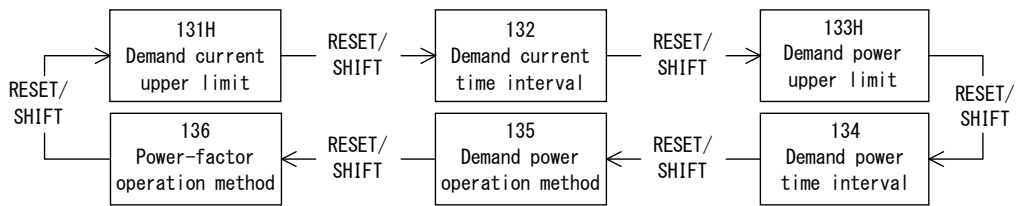

◆ 131H Demand current upper limit. 133H Demand active power upper limit.

Set the high-alarm value of demand current (DA) and demand active power (DW).

The setting range is 5 to 100% (1% step). Selection by **+** and **-**, set value is updated by **SET**.

Default setting: 80% (Demand current).

OFF [Non use] (Demand active power)

◆ 132 Demand current time interval. 134 Demand active power time interval.

Set the time interval (95% time interval) of demand current (DA) and demand active power (DW).

Selection by **+** and **-**, set value is updated by **SET**.

Default setting: 0 second (demand current, demand active power)

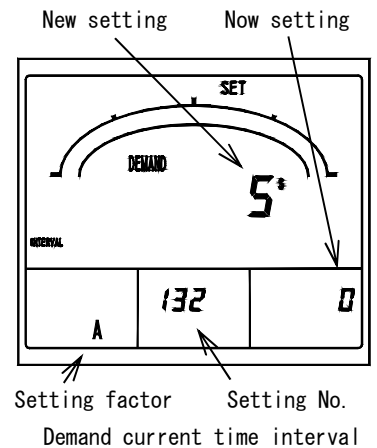
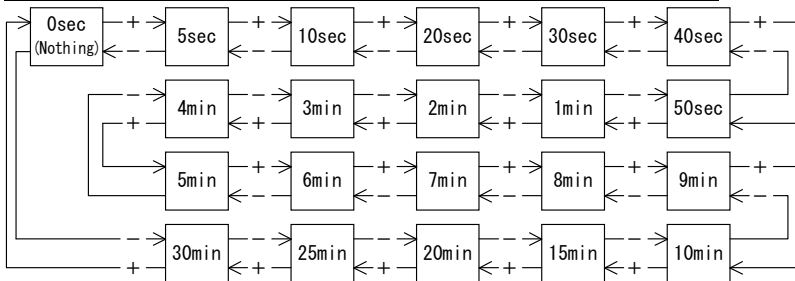

◆ 135 Demand active power operation method

The operating system of demand (DW) can be selected from d (operating system according with bimetallic type: demand) and A (Averaging arithmetic in demand time delay: average).

Selection by **+** and **-**, set value is updated by **SET**.

Default setting: d (Operating system according with bimetallic type)

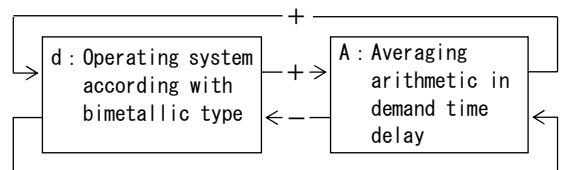

● Demand time delay characteristic (Demand current, Demand active power)

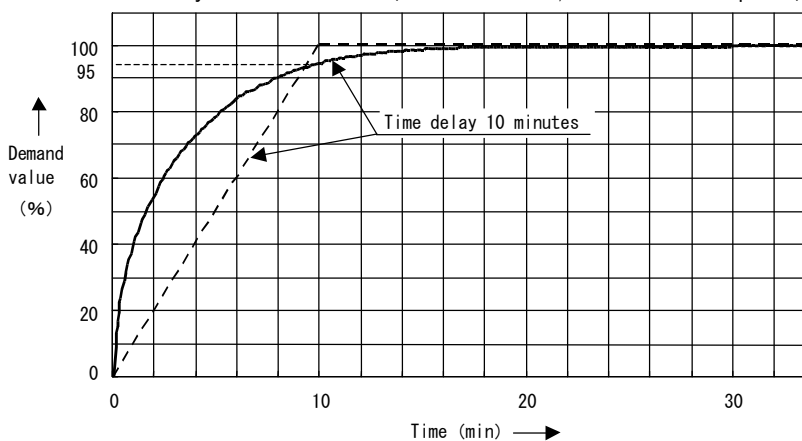

— Arithmetic method according with bimetallic type. (Indication time to 95% of a final constant value)  
 - - - Averaging arithmetic in demand time delay. (Averaging time in demand time delay.)

Arithmetic method

Demand current measurement : Arithmetic method according with bimetallic type.

Demand active power measurement : Arithmetic method according with bimetallic type (Default value).

Or the averaging arithmetic in a demand time interval.

One is selected by setting.

100% indication time is about 3 times the time delay at the case of the arithmetic method according with bimetallic type. (In case of 10 minutes/95% of time-interval, time to reach to 100% is about 30 minutes.)

Demand measurement is measured to the 2 times of the rated current, and the 2 time of a rated active power.

◆ 136 Power-factor operation method

The operation method of power-factor measurement can be selected from 0 (instant measurement) and 1 (averaging operator in a demand time interval). In case it is set as "1 (averaging operator in a demand time interval)", power-factor measurement is calculated from the operation method of a power demand time interval and a demand active power meter. Selection by  $\boxed{+}$  and  $\boxed{-}$ , set value is updated by  $\boxed{SET}$ .  
 Default setting : 0 (Instant measurement)

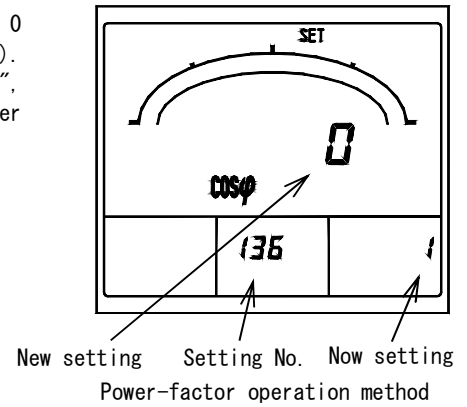
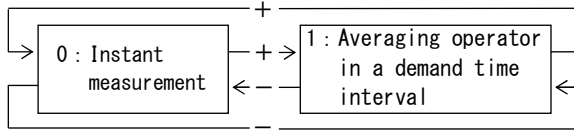

(4) 141H~14A Harmonic detection setting 【All models】

Set the high-alarm value of each harmonic (current, voltage) measurement factor, factor, 5th conversion detection characteristics, and average time interval is performed.

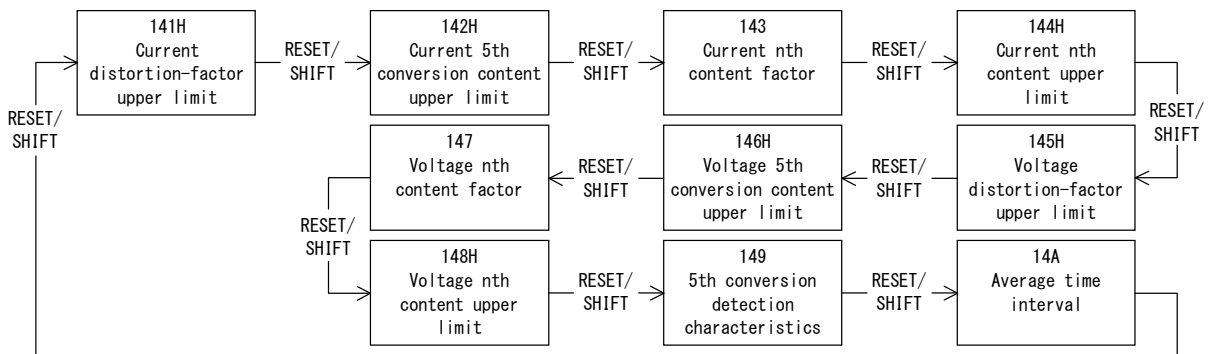

◆ 141H Current distortion-factor upper limit, 145H Voltage distortion-factor upper limit

Set the high-alarm value of distortion factor (current, voltage).  
 Setting range. Current : 5~100% (1% step)  
 Voltage : 1.0~20.0% (0.1% step)  
 Selection by  $\boxed{+}$  and  $\boxed{-}$ , set value is updated by  $\boxed{SET}$ .  
 Default setting : OFF [Non-use] (Current, Voltage)

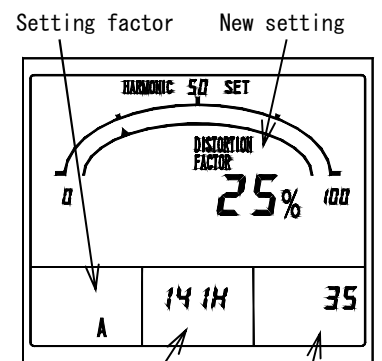

Setting No.    Now setting  
 Current distortion-factor upper limit

◆ 142H Current 5th conversion content upper limit, 146H Voltage 5th conversion content upper limit.

Set the high-alarm value of 5th conversion content (current, voltage).  
 Setting range. Current : 5~100% (1% step)  
 Voltage : 1.0~20.0% (0.1% step)  
 Selection by  $\boxed{+}$  and  $\boxed{-}$ , set value is updated by  $\boxed{SET}$ .  
 Default setting : OFF [Non-use] (Current, Voltage)

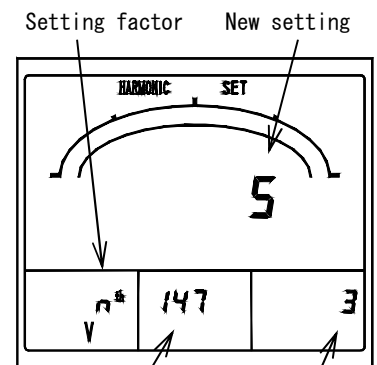

Setting No.    Now setting  
 Voltage nth content factor

◆ 143 Current nth content factor, 147 Voltage nth content factor.

Set the factor (order) of nth content (current, voltage).  
 An order can be selected from n= 3, 4, 5, 7, 9, 11, 13, 15.  
 Selection by  $\boxed{+}$  and  $\boxed{-}$ , set value is updated by  $\boxed{SET}$ .  
 Default setting : 5th(Current, Voltage)

◆ 144H Current nth content upper limit, 148H Voltage nth content upper limit.

Set the high-alarm value of nth content (current, voltage).  
 Setting range. Current : 5~100% (1% step)  
 Voltage : 1.0~20.0% (0.1% step)  
 Selection by  $\boxed{+}$  and  $\boxed{-}$ , set value is updated by  $\boxed{SET}$ .  
 Default setting : OFF [Non-use] (Current, Voltage)

◆ 149 5th conversion detection characteristics.

The detection characteristics of 5th conversion content can be selected from A (average mode) and I (inverse-time-delay mode).

In case of "A (average mode)", when average measured value (the average of instantaneous value in average time interval) exceeded the upper limit alarm value, it detects.

And in case of "I (inverse-time-delay mode)", when exceeding the upper limit warning value by anti-time limit characteristic of instantaneous value, it detects.

Selection by **[+]** and **[-]**, set value is updated by **[SET]**.

Default setting : I (inverse-time-delay mode)

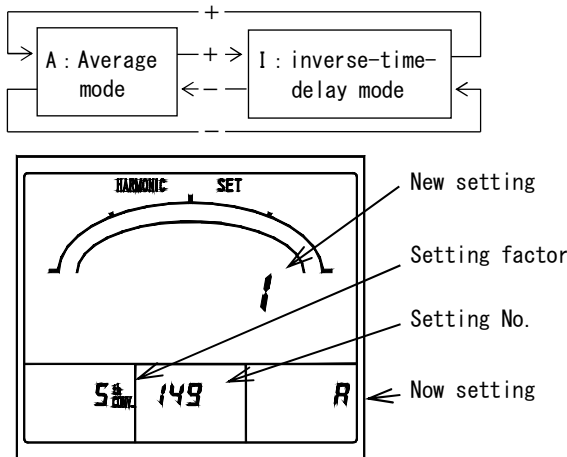

5th conversion detection

Alarm output, Inverse-time-delay characteristics  
In case of high-limit-setting value 35%  
(voltmeter 3.5%)

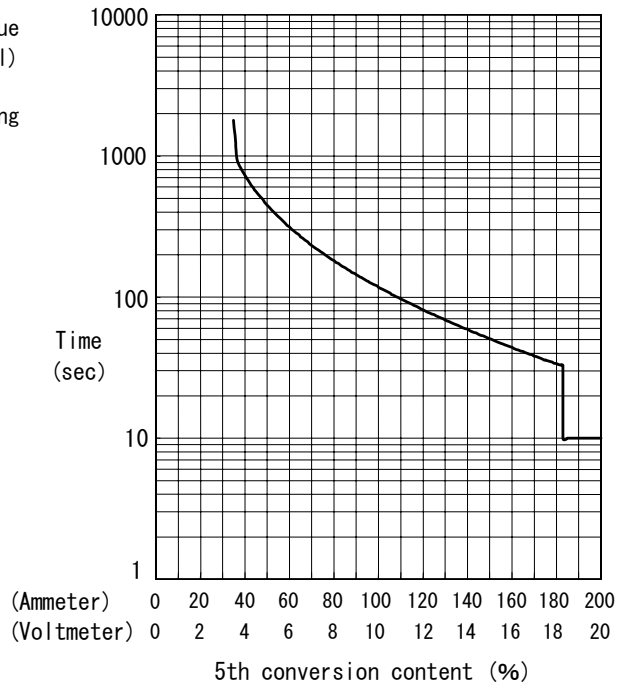

◆ 14A Average time interval

Set the average time interval of each harmonic measurement.

Selection by **[+]** and **[-]**, set value is updated by **[SET]**.

In addition, in case the detection characteristics of 5th conversion content are set as inverse-time-delay mode, in order that 5th conversion content may operate in inverse-time-delay characteristics, this time interval is disregarded. Default setting : 0 minute (With no average)

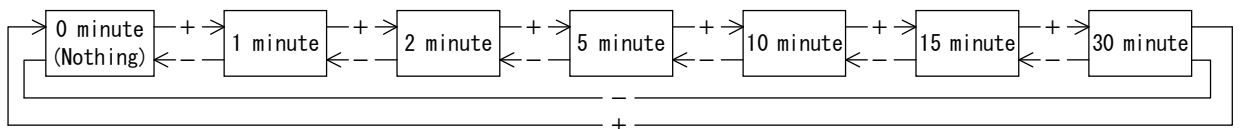

(5) 151H~152L Instant measurement detection setting 【Current input is excluded.】

An upper limit low-alarm value is set by instant measurement (voltage factor).

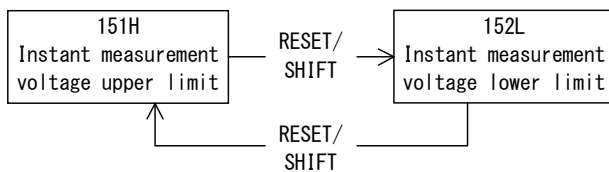

◆ 151H Instant measurement voltage upper limit.

152L Instant measurement voltage lower limit.

Set the high-alarm value and low-alarm value of instant measurement (voltage).

Setting range is 30~150% (1% step).

Selection by **[+]** and **[-]**, set value is updated by **[SET]**.

Default setting : OFF [Non-use] (Upper limit, lower limit)

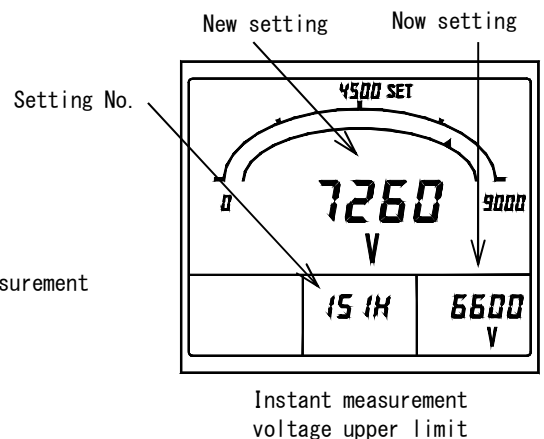



(6) 161~164 Leakage detection setting 【With leakage measurement】

The rated sensitivity current value of leakage measurement, a detection factor, the circuit configuration at the case of 3-phase 3-wire, and setting of ZCT to be used are performed.

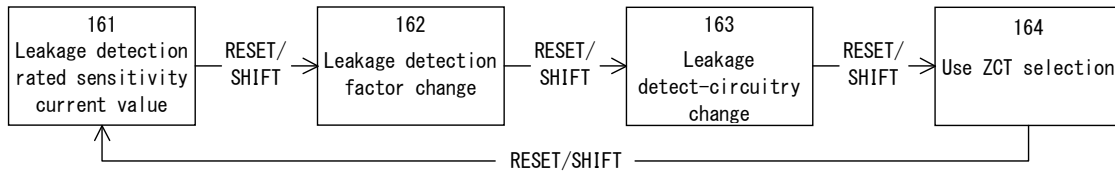

◆ 161 Leakage detection rated sensitivity current value

Set the rated sensitivity current value of current leakage.  
 Setting value can be selected from 0.03A, 0.05A, 0.1A, 0.2A, 0.4A, 0.8A.  
 Selection by  and , set value is updated by .

Default setting : 0.1A

◆ 162 Leakage detection factor change

Measurement of current leakage and detection factor can be selected from  $I_o$  and  $I_{gr}$ .  
 Selection by  and , set value is updated by .

However, a current input product constitutes  $I_o$  fixation and cannot carry out  $I_{gr}$  detection.

Default setting :  $I_o$

<Caution> Please apply a voltage input, in case you measure and detect  $I_{gr}$ .  
 In case the voltage input is not applied, measurement or detection of  $I_{gr}$  cannot be performed correctly.

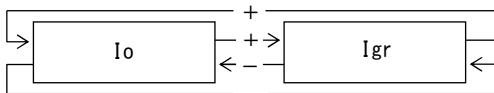

◆ 163 Leakage detect-circuitry change

The circuit configuration of the current-leakage detection in 3-phase 3-wire can be selected from 1-phase earthing, 1-phase earthing (negative phase sequence), and non-earthing.

Selection by  and , set value is updated by . Default setting : A(1 phase earthing)

<Caution> If actual connection is different from this setting, a current leakage  $I_{gr}$  cannot measure or detect correctly.  
 Setting of "1-phase earthing (negative phase sequence)" is setting for making  $I_{gr}$  measure and detect correctly, in case a circuit is a negative phase sequence. In the case of the right usual phase sequence, it is not necessary to make it this setting.

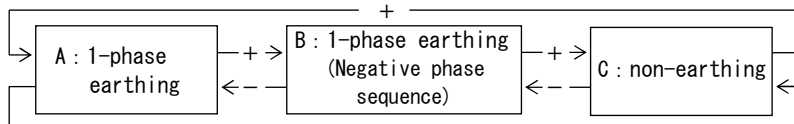

◆ 164 Use ZCT selection

ZCT used by current-leakage measurement can be selected.

Selection by  and , set value is updated by .

Default setting : 0(TYPE 0)

<Caution> If ZCT which you actually use is different from this setting, the error of current leakages  $I_o$  and  $I_{gr}$  will become large. In case you use ZCT(s) other than our company recommendation goods, please consult in advance.

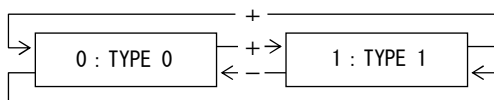

TYPE 0 : Our company recommendation product (Standard).  
 TYPE 1 : Except our company recommendation product.

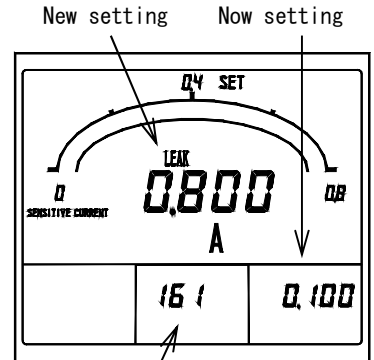

Setting No.

Leakage detection sensitivity current value

(7) 171~172 Backlight setting 【All models】 (However, the brightness of backlight is only white backlight products)  
 It sets action and brightness of backlight.

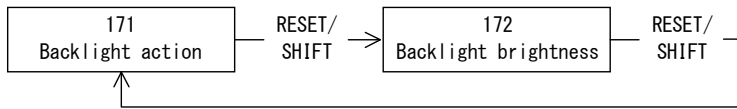

◆ 171 Backlight action

It can select from ON (always-on), AUTO (auto off), and OFF (always-off) about action of backlight.

If 5 minutes elapses without operating a switch in case it is set as "AUTO (auto off)", backlight will go out automatically.

After that, backlight will be turned on if either of switches is operated.

Selection by  and , set value is updated by .

Default setting: AUTO (Auto off)

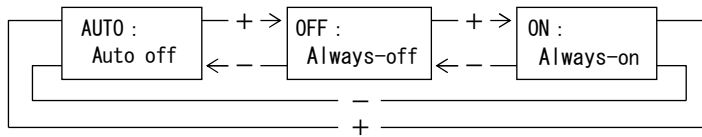

◆ 172 Backlight brightness 【white backlight products only】

It can select the brightness of backlight as five steps of 1 to 5.

Backlight becomes the darkest if it is set as "1".

Backlight becomes the brightest if it is set as "5".

Selection by  and , set value is updated by .

Default setting: 3 (Middle)

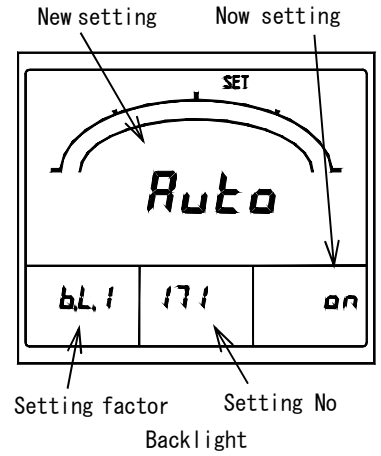

| Setting | Brightness               |
|---------|--------------------------|
| 5       | Bright<br>↑<br>↓<br>Dark |
| 4       |                          |
| 3       |                          |
| 2       |                          |
| 1       |                          |

5.3.2 Setting mode 2

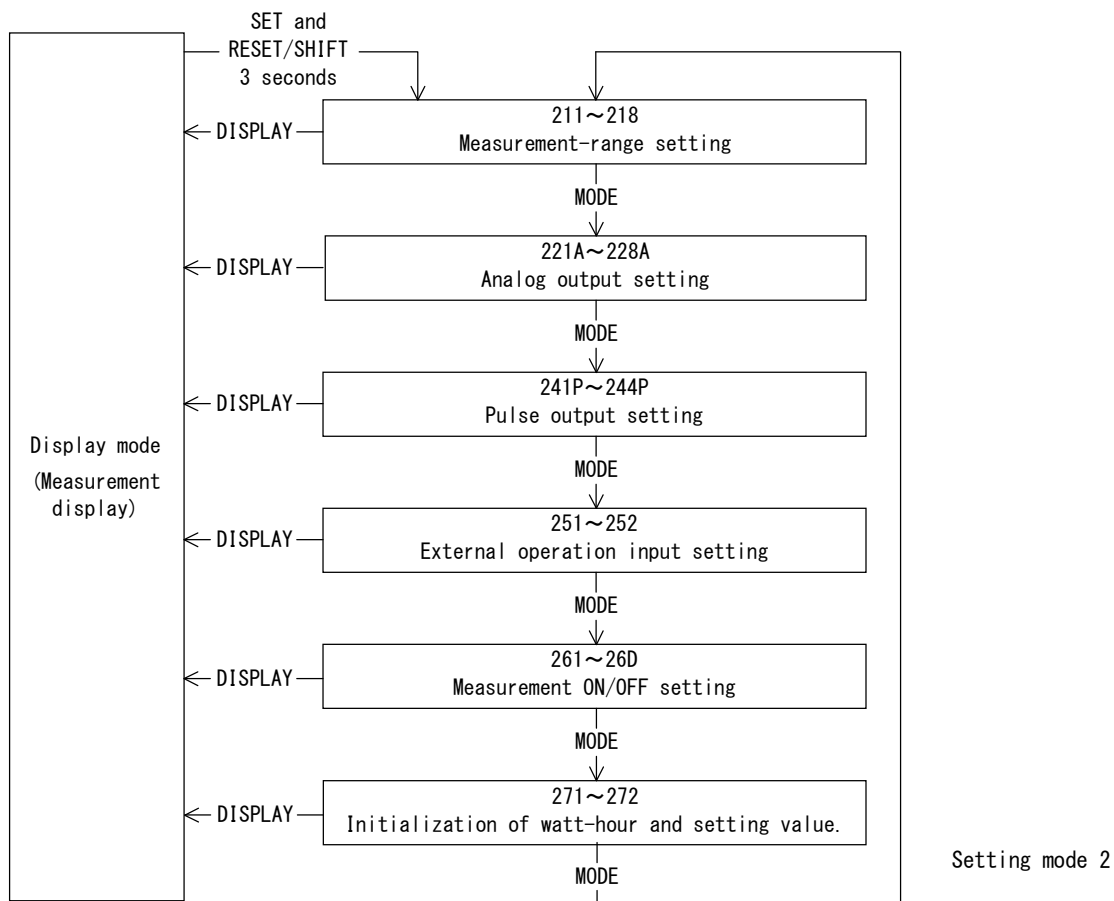

Setting mode 2 is selected by pressing **SET** and **RESET/SHIFT** switches continuously for longer than 3 seconds. Pushing **MODE** switch performs movement of setting item. The present mode can be returned to the display mode by pressing **DISPLAY** switch.

< Caution >

If setting change should have been mistaken, a display and output of measurement are not obtained correctly. Therefore, users must not set. The setting item without the corresponding option is not displayed.

(1) 211~218 Measurement-range setting **【All models】**  
 Setting of measurement range in each measurement factors.

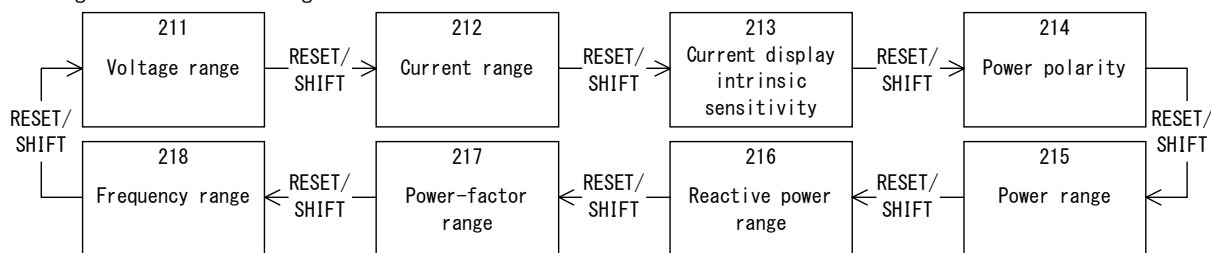

◆ 211 Voltage range

Set the voltage range (VT ratio). Change of this setting also sets the measurement range of active power and reactive power automatically simultaneously.

Selection by **[+]** and **[-]**, set value is updated by **[SET]**.

Default setting : 6600V (3ϕ 3W)、110.0V (1ϕ 3W)、3300V (1ϕ 2W)

Voltage measurement range (34 range)

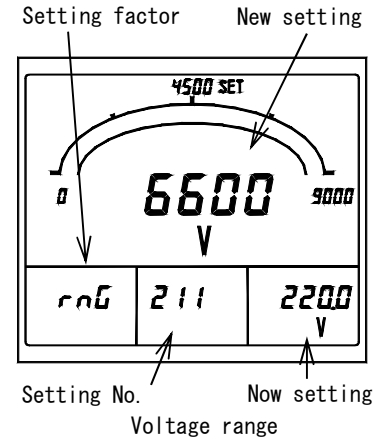
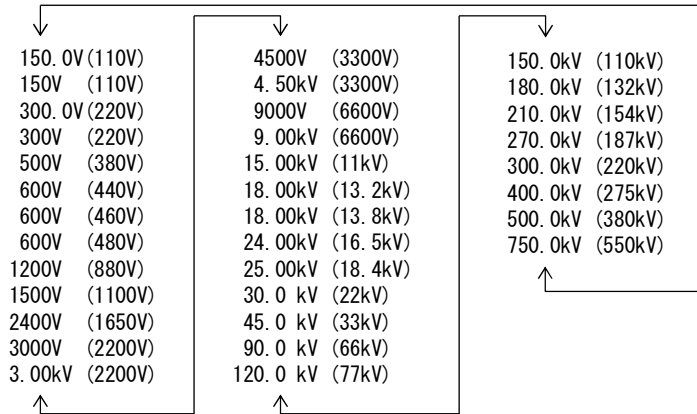

◆ 212 Current range

Set the current range (CT ratio). Change of this setting also sets the measurement range of active power and reactive power automatically simultaneously.

Selection by **[+]** and **[-]**, set value is updated by **[SET]**.

Default setting : 100.0A (3ϕ 3W)、500A (1ϕ 3W)、50.0A (1ϕ 2W)

Current-measurement range (76 range)

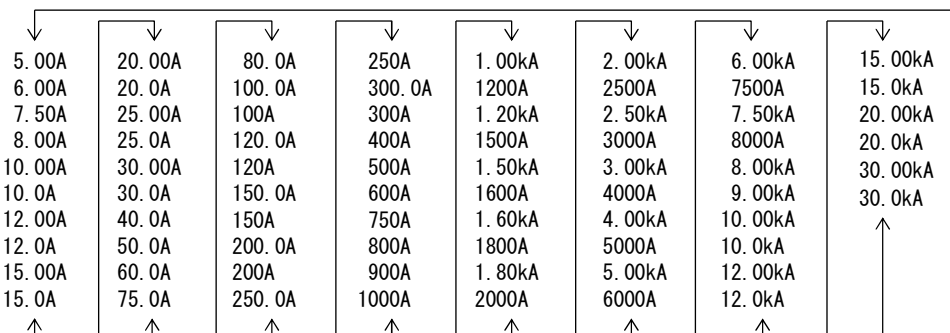

◆ 213 Current display intrinsic sensitivity

Set the full scale of current meter.

The setting range is 40 to 120% of CT ratio. And, it can select from the following values.

Selection by **[+]** and **[-]**, set value is updated by **[SET]**.

Default setting : 100.0A (3ϕ 3W)、500A (1ϕ 3W)、50.0A (1ϕ 2W)

|                                                                                                      |                                   |
|------------------------------------------------------------------------------------------------------|-----------------------------------|
| The measurement range (current, active power, reactive power) which can be set. (× 10 <sup>n</sup> ) |                                   |
| 1. <input type="checkbox"/>                                                                          | 1.0 / 1.2 / 1.4 / 1.5 / 1.6 / 1.8 |
| 2. <input type="checkbox"/>                                                                          | 2.0 / 2.4 / 2.5 / 2.8             |
| 3. <input type="checkbox"/>                                                                          | 3.0 / 3.2 / 3.6                   |
| 4. <input type="checkbox"/>                                                                          | 4.0 / 4.2 / 4.5 / 4.8             |
| 5. <input type="checkbox"/>                                                                          | 5.0 / 5.6                         |
| 6. <input type="checkbox"/>                                                                          | 6.0 / 6.4                         |
| 7. <input type="checkbox"/>                                                                          | 7.2 / 7.5                         |
| 8. <input type="checkbox"/>                                                                          | 8.0 / 8.4                         |
| 9. <input type="checkbox"/>                                                                          | 9.0 / 9.6                         |

Example )

In case of CT ratio=100.0A.

· 40% of 100A is 40A.

· 120% of 100A is 120A.

A measurement range can be selected within the limits of 40 to 120A.

Therefore, a left table

A measurement range can be selected from 40/42/45/48/50/56/60/64/72/75/80/84/90/96/100/120A.

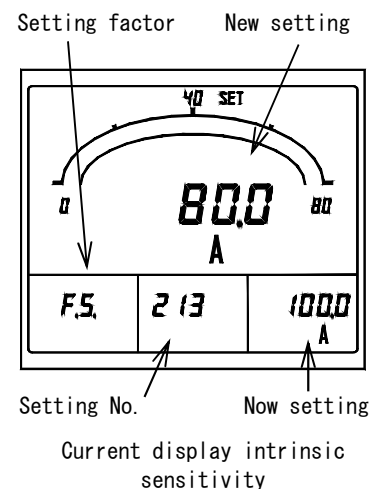

◆ 214 Active power polarity

A swing display of active power meter can be selected from P (one side swing) and - (both swings).

Selection by + and -, set value is updated by .

Default setting: P (One-side swing)

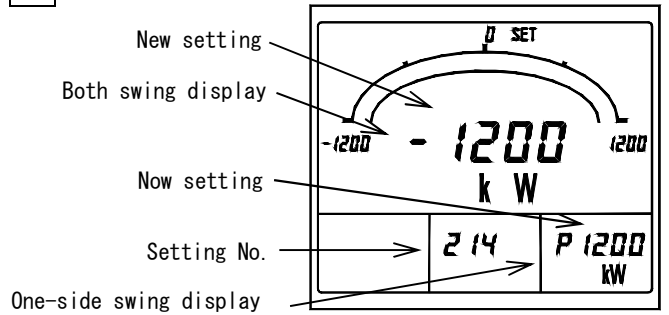
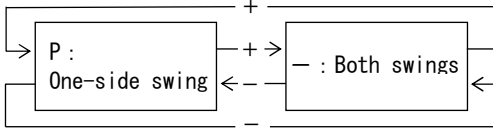

Power polarity

◆ 215 Active power range

Set the full scale of active power meter. The setting range is 40 to 115% of range of a VT ratio × CT ratio. And it can select from "213 current display intrinsic sensitivity" tables.

Selection by + and -, set value is updated by .

<Caution> VT ratio: In case of 220V direct input. Calculates by VT ratio=2.

CT ratio: In case of 1A input. Calculates by CT ratio÷5.

Default setting: 3φ3W: 1200kW, 1φ3W: 100.0kW, 1φ2W: 150.0kW

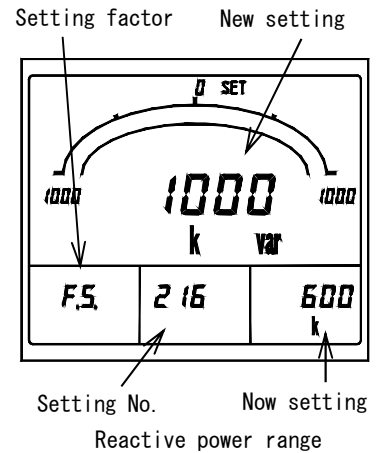

Reactive power range

◆ 216 Reactive power range

Set the full scale of reactive power meter.

The setting range is 30 to 115% of range of a VT ratio × CT ratio.

And it can select from "213 current display intrinsic sensitivity" tables.

Selection by + and -, set value is updated by .

<Caution> VT ratio: In case of 220V direct input. Calculates by VT ratio=2.

CT ratio: In case of 1A input. Calculates by CT ratio÷5.

Default setting: 3φ3W: 600kvar, 1φ3W: 50.0kvar, 1φ2W: 75.0kvar

◆ 217 Power-factor range

A power-factor measurement range can be selected from 0.500~1.000~0.500/0.000~1.000~0.000

Change of this setting also sets the analog output range of a power-factor automatically simultaneously.

Selection by + and -, set value is updated by .

Default setting: 0.500~1.000~0.500

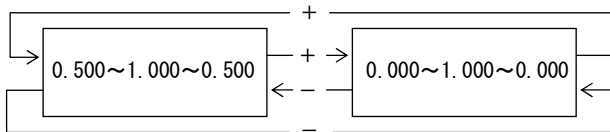

◆ 218 Frequency range

A frequency measurement range can be selected from 45.0~55.0Hz/55.0~65.0Hz/45.0~65.0Hz. Change of this setting also sets the analog output range of a frequency automatically simultaneously.

Selection by + and -, set value is updated by .

Default setting: 45.0~65.0Hz

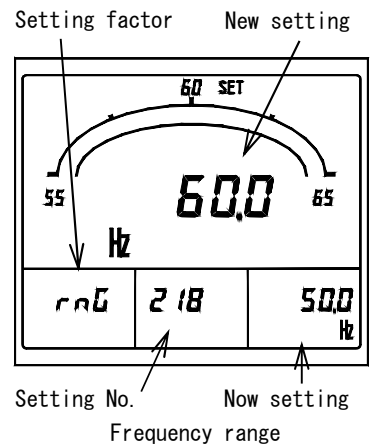
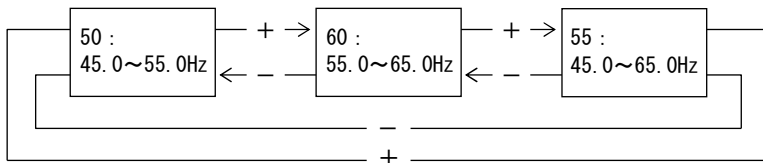

Frequency range

(2) 221A~228A Analog output setting 【With an analog output option】

Various setting of analog output is performed.

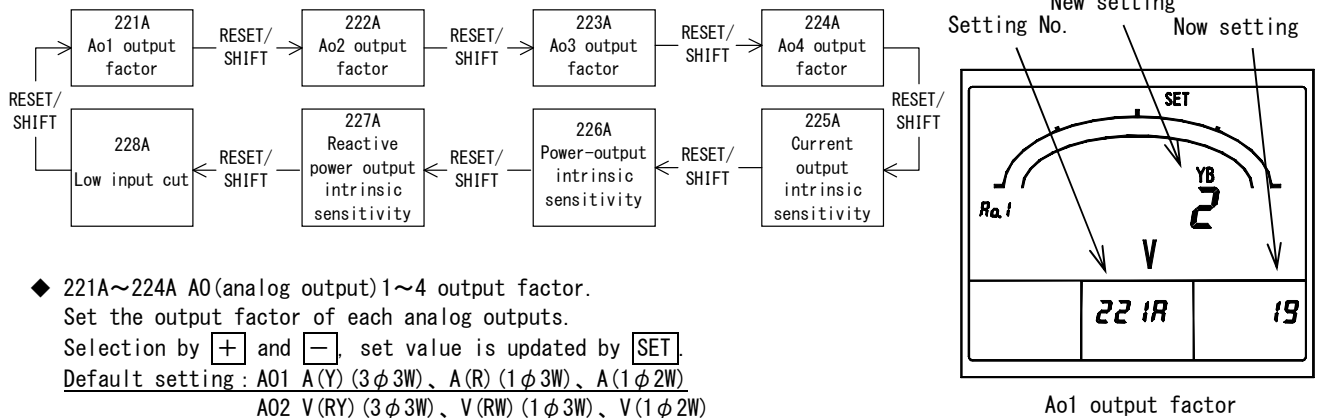

◆ 221A~224A A0(analog output)1~4 output factor.

Set the output factor of each analog outputs.

Selection by  $\boxed{+}$  and  $\boxed{-}$ , set value is updated by  $\boxed{SET}$ .

Default setting : A01 A (Y) (3  $\phi$  3W)、A (R) (1  $\phi$  3W)、A (1  $\phi$  2W)

A02 V (RY) (3  $\phi$  3W)、V (RW) (1  $\phi$  3W)、V (1  $\phi$  2W)

A03 W (3  $\phi$  3W/1  $\phi$  3W/1  $\phi$  2W)

A04  $\cos \phi$  (3  $\phi$  3W/1  $\phi$  3W/1  $\phi$  2W)

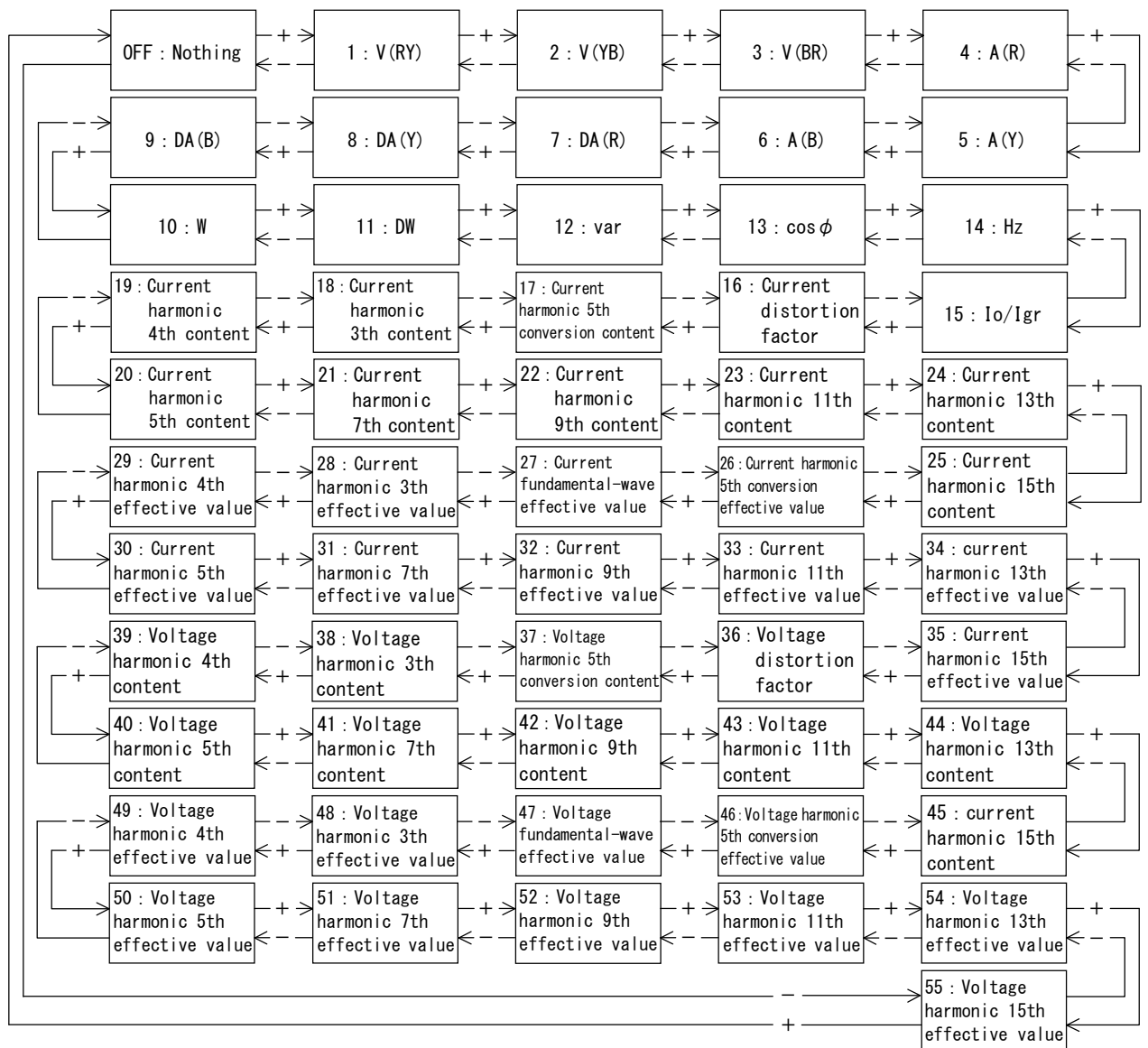

- ◆ 225A Current output intrinsic sensitivity,
- 226A Active power output intrinsic sensitivity,
- 227A Reactive power output intrinsic sensitivity.

Output intrinsic sensitivity (% of an output to an input) is set about each analog output of current, active power, and reactive power. The setting range can be selected from the following.

- Current : 40.0~120.0% (0.1% step)
- Active power : 40.0~115.0% (0.1% step)
- Reactive power : 30.0~115.0% (0.1% step)

Selection by + and -, set value is updated by .

Default setting: 100.0% (Current, Active power),  
50.0% (Reactive power)

Example) 3φ3W, 9000V, 100.0A, 1200kW range, Analog output DC4~20mA  
 -Set 100.0%. Analog output is DC20mA in 1200kW of primary inputs.  
 -Set 80.0%. Analog output is DC20mA in 1200kW×0.8=960kW of primary input.

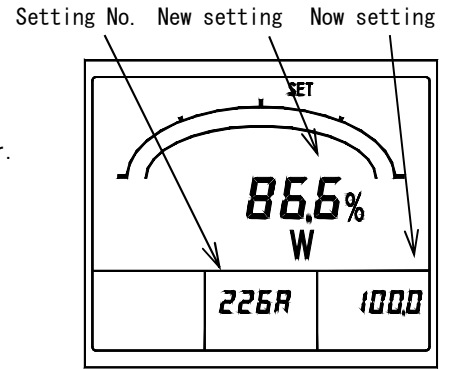

Power-output intrinsic sensitivity,

- ◆ 228A Low input cut

It is the function which makes analog output a lower limit at the case of a minute input (input which corresponds to 0.5% or less). A function can be selected from ON (Use) and OFF (Non-use).

Selection by + and -, set value is updated by .

Default setting: OFF (Non-use)

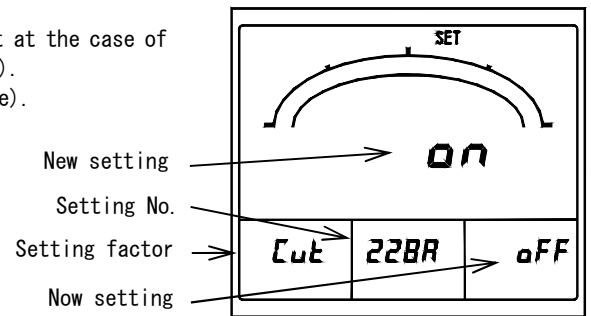

Low input cut

(3) 241P~244P Pulse output setting 【With a pulse output option】

Various setting of a pulse output is performed.

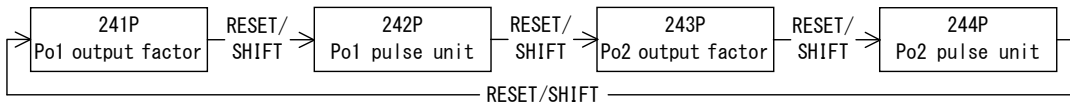

- ◆ 241P PO(pulse output) 1 output factor,
- 243P PO(pulse output) 2 output factor

Set the output factor of each pulse output. Selection by + and -, set value is updated by .

Default setting: Wh (P01, P02)

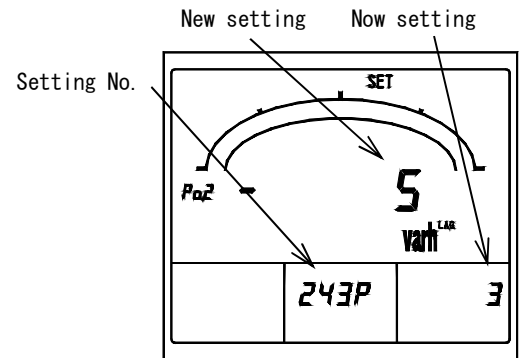
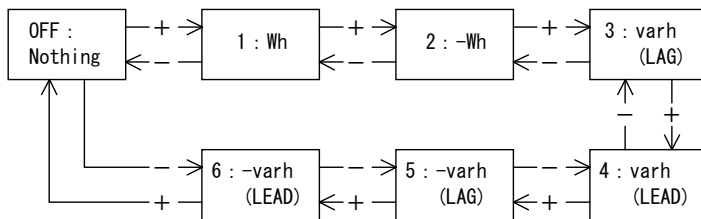

Po2 output factor

- ◆ 242P PO(pulse output) 1 pulse unit,
- 244P PO(pulse output) 2 pulse unit

Set the pulse unit of each pulse output. A pulse unit can be selected from four types. The pulse unit that can be selected is decided with full-load power.

Default setting: 10kWh/p [3φ3W] (P01, P02),  
1kWh/p [1φ3W/1φ2W] (P01, P02)

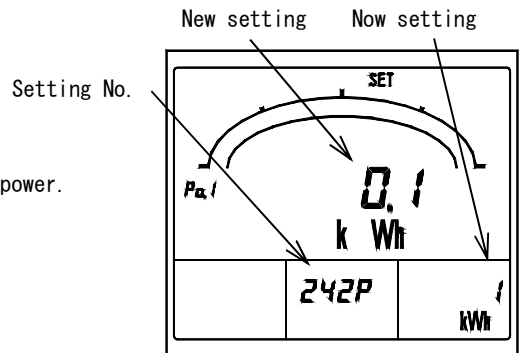

Po1 pulse unit

(4) 251~252 External operation input setting 【With an external operation input option】  
 Various setting of external operation input is performed.

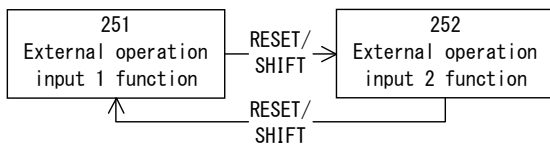

- ◆ 251 External operation input 1 function, 252 External operation input 2 function

The function of each external operation input (alarm reset, maximum / minimum reset, measurement factor change, phase change) can be selected.

Selection by  $\boxed{+}$  and  $\boxed{-}$ , set value is updated by  $\boxed{SET}$ .

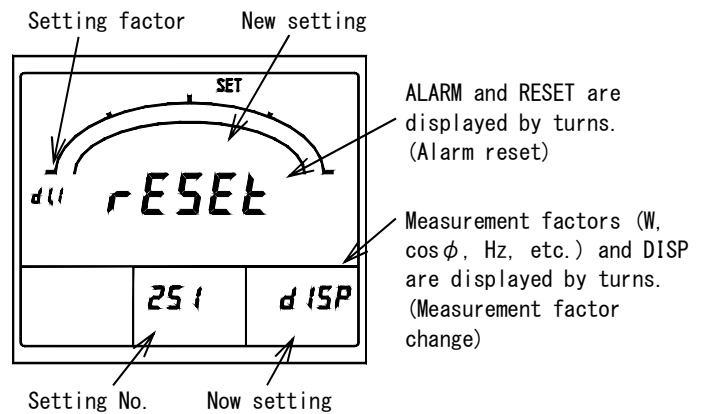

Default setting (With an alarm-output option)

Alarm reset (External operation input 1)

Maximum / minimum reset (External operation input 2)

Default setting (With no alarm-output option)

Maximum / minimum reset (External operation input 1)

Measurement factor change (External operation input 2)

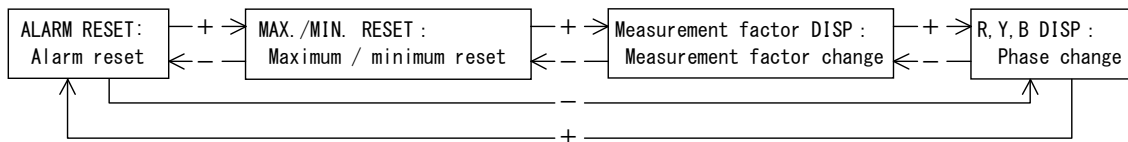

• About the setting display in an external operation input function

| Function                  | The contents of a display at the case of function setting                                                                               | "Now setting" display point | "New setting" display point |
|---------------------------|-----------------------------------------------------------------------------------------------------------------------------------------|-----------------------------|-----------------------------|
| Alarm reset               | "ALARM" and "RESET" are displayed by turns by 7 segment displays of the main monitor.                                                   | Sub-monitor (right)         | Main monitor                |
| Maximum / minimum reset   | "RESET" is displayed by 7 segment displays of the main monitor. And, "MAX" and "MIN" display by turns.                                  |                             |                             |
| Measurement factor change | "DISP" is displayed by 7 segment displays of the main monitor. And, each measurement factor (units of A, V, W, etc.) displays by turns. |                             |                             |
| Phase change              | "DISP" is displayed by 7 segment displays of the main monitor. And, each phase (R, Y, B, W) displays by turns.                          |                             |                             |



- (5) 261~26D Measurement ON/OFF setting 【All models (However, a current leakage is with leakage measurement )】  
 Measurement display ON/OFF setting of each measurement factor is performed.  
 Selection by **[+]** and **[-]**, set value is updated by **[SET]**.  
 Default setting: ON (All measurement factors)

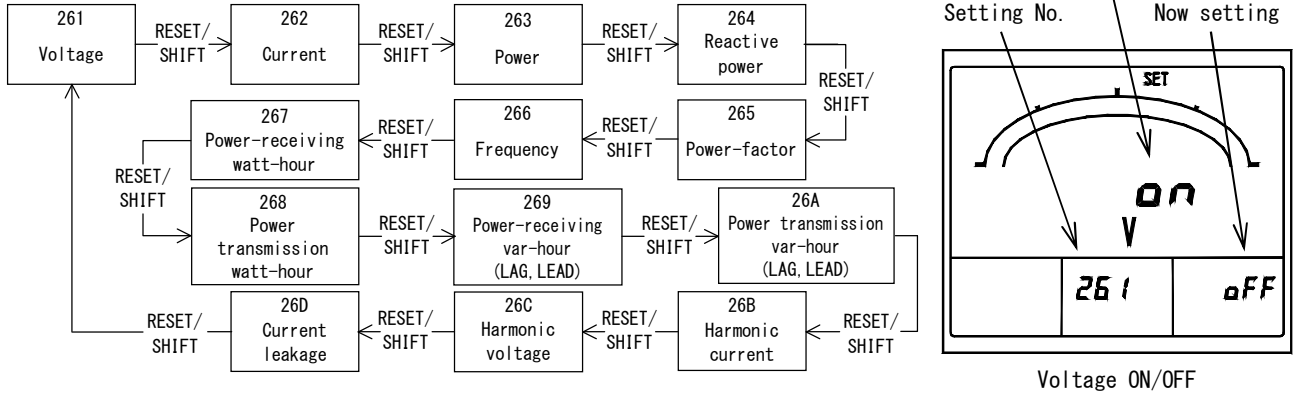

- (6) 271~272 Initialization of watt-hour and setting value. 【All models】  
 Package reset of watt-hour is performed. And, each set value is initialized (returns to default setting).

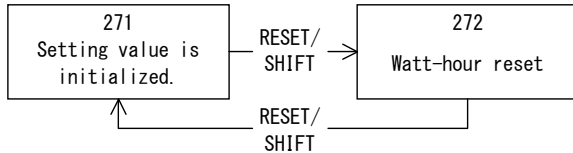

- ◆ 271 Initialization of setting value  
 Each set value is initialized (returns to default setting).  
 Pushing **[SET]** for 3 seconds initializes all set values.

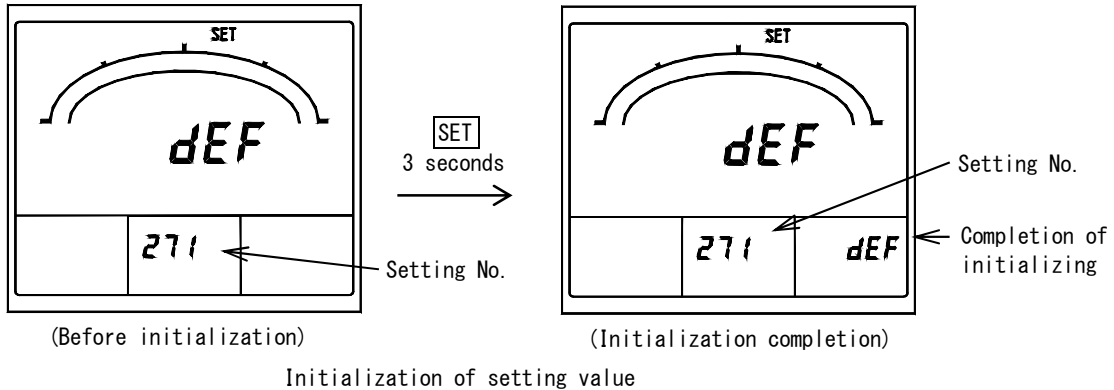

- ◆ 272 Watt-hour reset  
 Integrated value of each electric-energy display is cleared (=0). By pushing **[SET]** for 3 seconds, all integrated value (Wh, -Wh, var (LAG), -var (LAG), var (LEAD), var (LEAD)) is cleared by package.

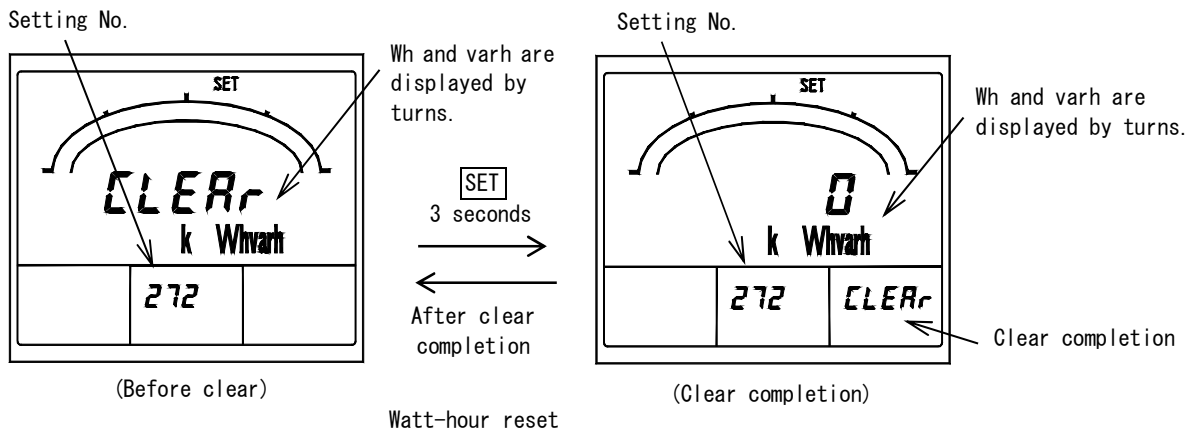

## 5.3.3 Setting mode 3

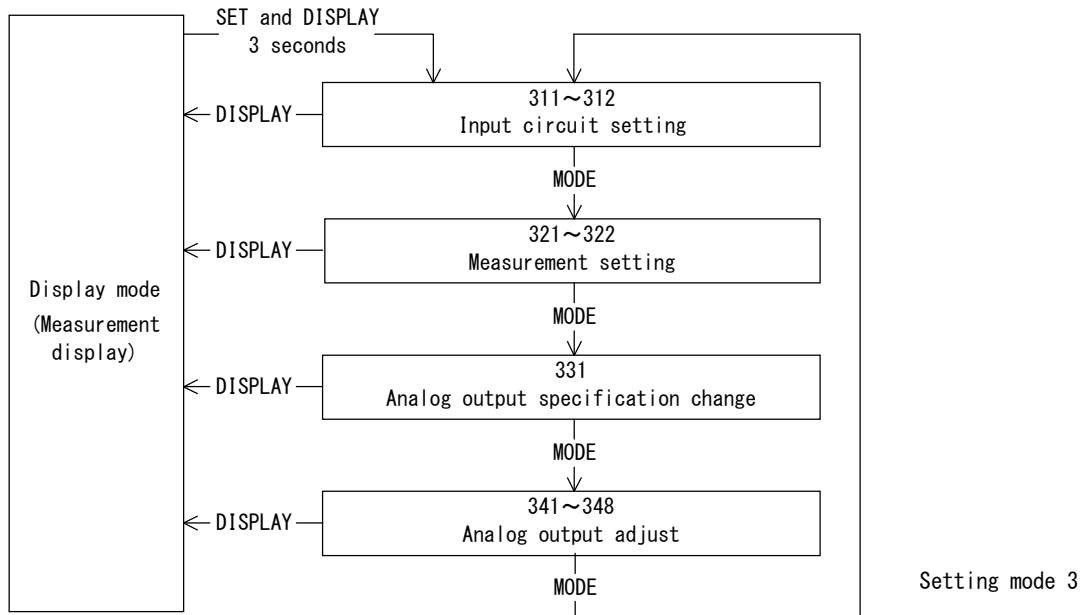

Setting mode 3 is selected by pressing **SET** and **DISPLAY** switches continuously for longer than 3 seconds. Pushing **MODE** switch performs movement of setting item.

The present mode can be returned to the display mode by pressing **DISPLAY** switch.

< Caution >

If setting change should have been mistaken, a display and output of measurement are not obtained correctly. Therefore, users must not set. The setting item without the corresponding option is not displayed.

(1) 311~312 Input circuit setting **【All models】**

Set the input circuit and phase wire and input voltage / phase-voltage full scale.

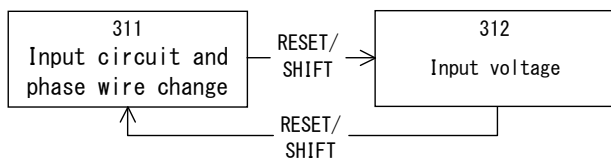

◆ 311 Input circuit and phase wire change

Set the input circuit and phase wire (1φ3W).

Selection by **+** and **-**, set value will be updated if **SET** is pushed for 3 seconds.

Default setting: 3φ3W (3φ3W, No designation),  
1φ3W [R-W-B] (1φ3W), 1φ2W (1φ2W)

<Caution>

- When this setting is changed, it will become the default setting of the input circuit after all set values changing.
- The right measurement cannot be performed if setting of actual connection and phase wire are different.

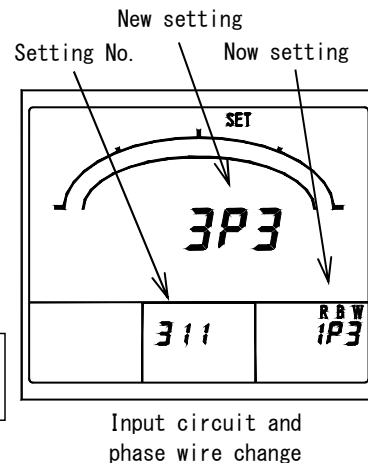
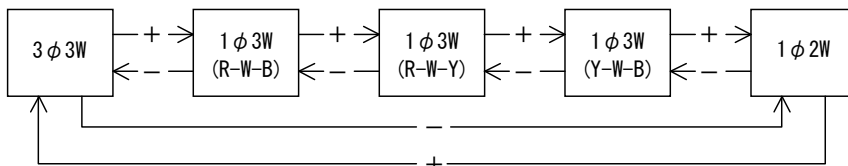

◆ 312 Input voltage

Set the input voltage (3φ3W, 1φ2W) or phase-voltage full scale (1φ3W).

In 3φ3W/1φ2W and 1φ3W, the contents of a setting are different.

Selection by **+** and **-**, set value is updated by **SET**.

Default setting: 300V (1φ3W)

Default setting: 110V (3φ3W, 1φ2W or no designation)

• 3φ3W, 1φ2W

• 1φ3W

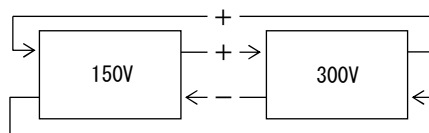
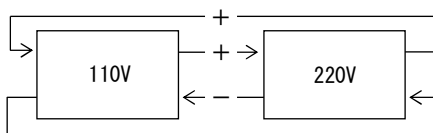

Setting of 300V, Output is AC0~150V/DC4~12mA.

Setting of 150V, Output is AC0~150V/DC4~20mA.

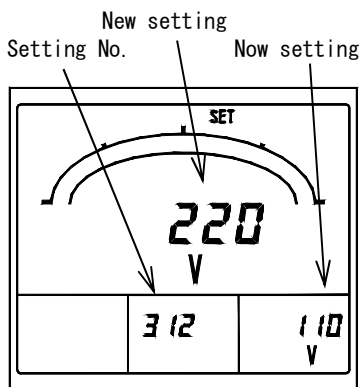

Input-voltage rating (3φ3W)

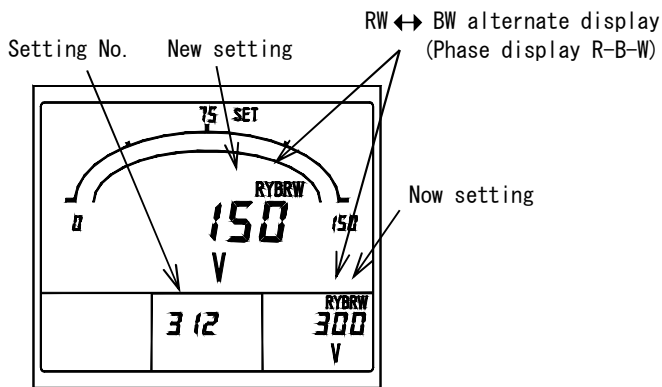

Phase-voltage full scale (1φ3W)

(2) 321~322 Measurement setting [All models]

Set the dead band of measurement display, and with or without of tidal current measurement.

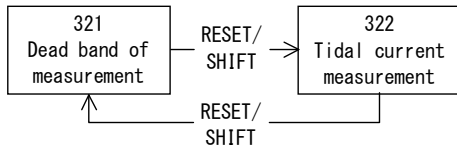

◆ 321 Measurement dead band

Set the dead band of measurement display. By this setting, variation of less than this set value is disregarded by voltage, current, active power, and reactive power measurement display.

Setting range : 0.0~2.0% (0.1% step)

Selection by  $\boxed{+}$  and  $\boxed{-}$ , set value is updated by  $\boxed{SET}$ .

Default setting : 0.0% (Nothing)

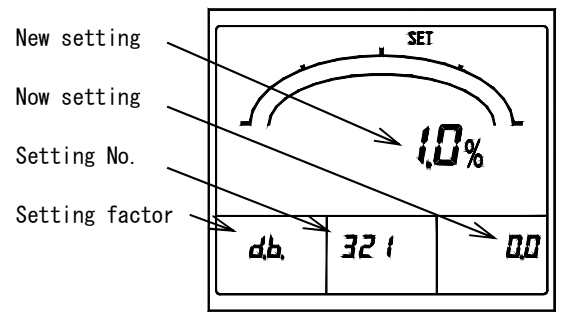

Dead band of measurement

◆ 322 Tidal current measurement

By measurement of reactive power and a power-factor, 0 (general measurement) or 1 (tidal current measurement which was conscious of power transmission/power receiving) can be selected.

Selection by  $\boxed{+}$  and  $\boxed{-}$ , set value is updated by  $\boxed{SET}$ .

Default setting : 0 (General measurement)

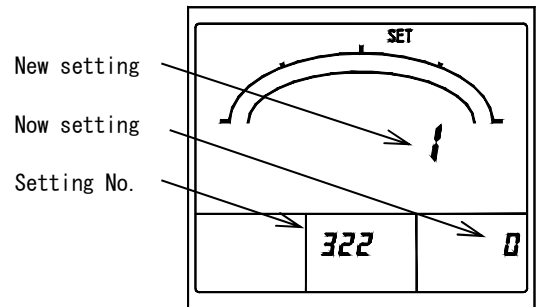
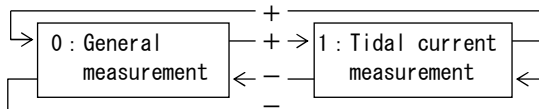

Tidal current measurement

(General measurement)

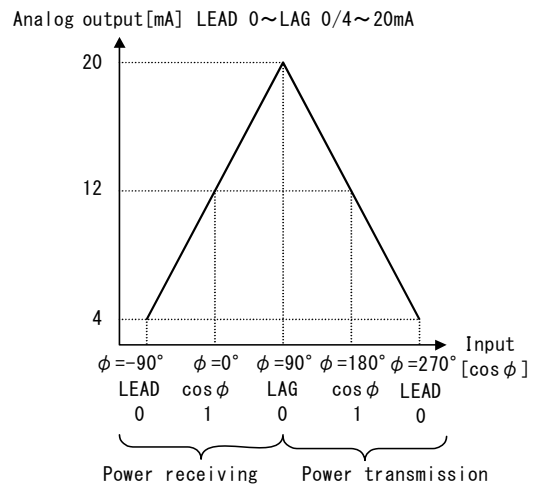
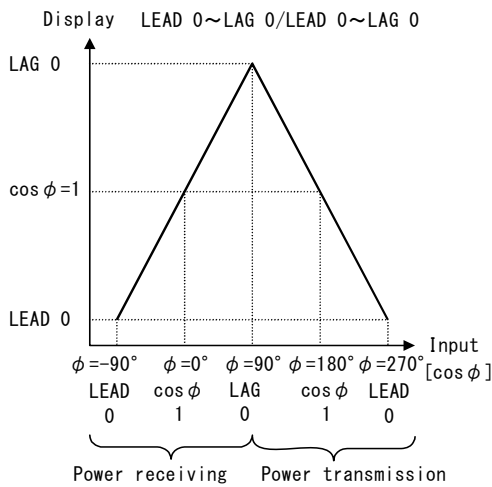

(Tidal current measurement)

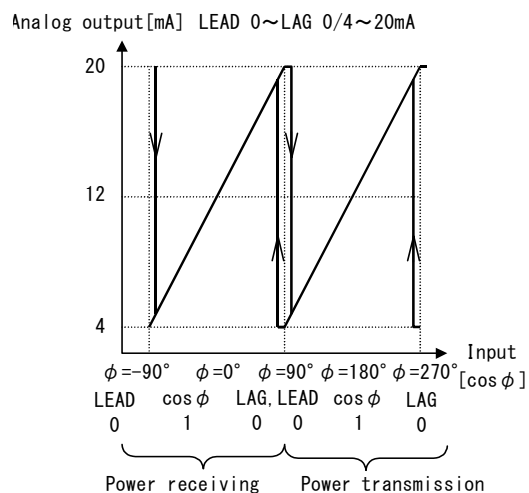
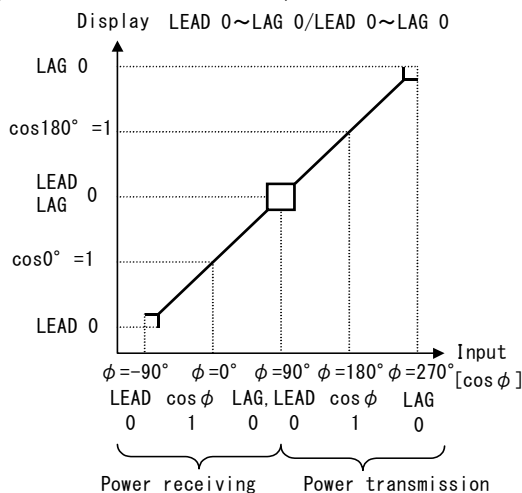

(3) 331 Analog output specification setting 【With analog output (DC0~5V or DC1~5V)】

Set the specification of analog output (DC0~5V/DC1~5V).

Selection by **[+]** and **[-]**, set value is updated by **[SET]**.

Default setting: DC1~5V or DC0~5V (Designation)

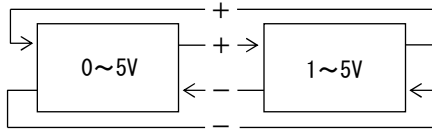

<Note> This setting does not exist at the time of an analog output insulation product.

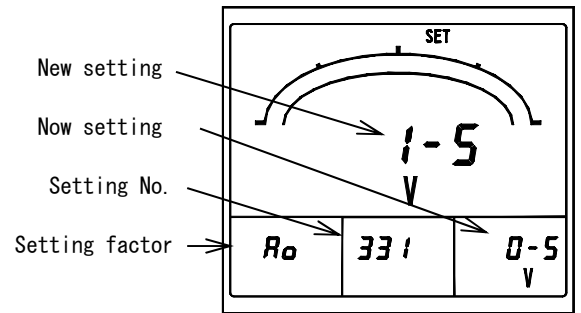

Analog output specification

(4) 341~348 Analog output adjustment 【With analog output】

The bias and span of each analog output are adjusted.

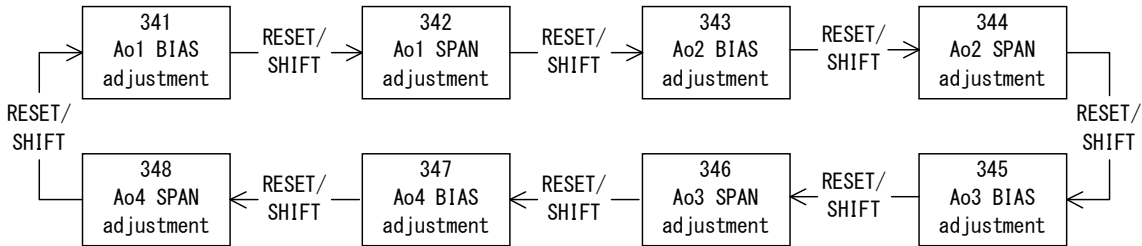

- ◆ 341 AO(Analog output)1 bias adjustment,
- 343 AO(Analog output)2 bias adjustment,
- 345 AO(Analog output)3 bias adjustment,
- 347 AO(Analog output)4 bias adjustment.

The bias of each analog output is adjusted.

Setting range : ±10.0% (0.1% step)

Selection by **[+]** and **[-]**, set value is updated by **[SET]**.

- ◆ 342 AO(Analog output)1 span adjustment,
- 344 AO(Analog output)2 span adjustment,
- 346 AO(Analog output)3 span adjustment,
- 348 AO(Analog output)4 span adjustment.

The span of each analog output is adjusted.

Setting range : ±10.0% (0.1% step)

Selection by **[+]** and **[-]**, set value is updated by **[SET]**.

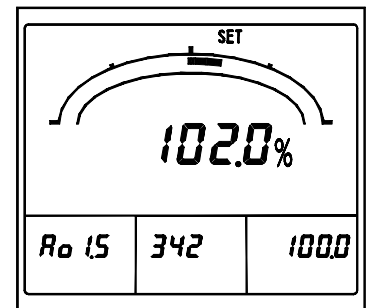

Ao1 span adjustment

## 6. Specification

## 6.1 Specification and intrinsic error.

| Input circuit                         | Input                                                                         |                               |
|---------------------------------------|-------------------------------------------------------------------------------|-------------------------------|
| 3-phase 3-wire<br>Single-phase 2-wire | AC110V, 220V common use.<br>AC 5A or AC 1A 50/60Hz Designation                |                               |
| Single-phase 3-wire                   | AC100-200V <sup>(48)</sup><br>AC 5A or AC 1A 50/60Hz Designation              |                               |
| Zero-phase current                    | Rated sensitivity current value.<br>0.03A / 0.05A / 0.1A / 0.2A / 0.4A / 0.8A | Only with leakage measurement |

| Measurement item                                            | Measurement range / Display specification                                                                                                                             | Current input                                                | Voltage input | Intrinsic error <sup>(49)</sup> |                                            | Maximum measurement | Minimum measurement | Note                                                                                                                                  |
|-------------------------------------------------------------|-----------------------------------------------------------------------------------------------------------------------------------------------------------------------|--------------------------------------------------------------|---------------|---------------------------------|--------------------------------------------|---------------------|---------------------|---------------------------------------------------------------------------------------------------------------------------------------|
|                                                             |                                                                                                                                                                       |                                                              |               | Digital display                 | Analog output Pulse output <sup>(50)</sup> |                     |                     |                                                                                                                                       |
| Voltage                                                     | AC150V~750.0kV (34 range)                                                                                                                                             |                                                              | ○             | ±1.0%                           | ±0.5%                                      | ○                   | ○                   | RY-YB-BR line change <sup>(51)</sup>                                                                                                  |
| Current                                                     | Maximum demand <sup>(59)</sup> , Demand, Instant<br>AC5.00A~30.0kA (76 range)                                                                                         | ○                                                            |               | ±1.0%                           | ±0.5%                                      | ○                   | ○                   | R-Y-B phase change <sup>(52)</sup><br>Possible to set a range of indication and output apart from the CT ratio.                       |
| Active power                                                | Maximum demand <sup>(59)</sup> , Demand, Instant<br>200W~1000MW (Range select)<br>In voltage and current range.<br>One-side swing or both side swings can be setting. |                                                              |               | ±1.0%                           | ±0.5%                                      | ○                   | ○                   | Range of an analog output can be set as indication independently. <sup>(53)</sup>                                                     |
| Reactive power                                              | LEAD, LAG 150var~1000Mvar<br>(Range select)<br>In voltage and current range.                                                                                          |                                                              |               | ±1.0%                           | ±0.5%                                      | ○                   | ○                   | Range of an analog output can be set as indication independently. <sup>(54)</sup>                                                     |
| Power factor                                                | LEAD 0.500~1.000~LAG 0.500<br>or<br>LEAD 0.000~1.000~LAG 0.000<br>Range select                                                                                        |                                                              |               | ±2.0%                           | ±2.0%                                      | ○                   | ○                   | In case input is below 20% of voltage range or below 2% of current range :<br>cos $\phi$ =1.<br>(Output is cos $\phi$ =1 equivalence) |
| Frequency                                                   | 45.0~55.0Hz or<br>55.0~65.0Hz or<br>45.0~65.0Hz<br>Range select                                                                                                       |                                                              | ○             | ±0.5%                           | ±0.5%                                      | ○                   | ○                   | 0.0Hz in case input is below 20% of voltage range.<br>Output is a lower limit value. (Lower limit value -1% : % for output span)      |
| Current leakage <sup>(55)</sup><br>Io method,<br>Igr method | Current leakage<br>AC0.03A~0.8A (6 range)                                                                                                                             | ○                                                            | ○             | ±2.5% <sup>(56)</sup>           | ±2.5% <sup>(56)</sup>                      | ○                   |                     | % for rated sensitivity current value.<br>An input (ZCT primary) 3mA or less becomes zero display.                                    |
| Distortion factor                                           | Voltage                                                                                                                                                               |                                                              | ○             | ±1.0%                           | ±2.5%                                      | ○                   |                     | Digital display is % to 100% of distortion factors.                                                                                   |
|                                                             | Current                                                                                                                                                               | 0.0~20.0%<br>(Second to 15th harmonic) RY-YB <sup>(57)</sup> | ○             | ±2.5%                           | ±2.5%                                      | ○                   |                     |                                                                                                                                       |
| Harmonic nth effective value                                | Voltage                                                                                                                                                               |                                                              | ○             | ±1.5%                           | ±1.5%                                      | ○                   |                     | Digital display is % to a voltage range.                                                                                              |
| Fundamental -wave effective value                           | Current                                                                                                                                                               |                                                              | ○             | ±1.5%                           | ±1.5%                                      | ○                   |                     | Digital display is % to a current range.                                                                                              |

| Measurement item                        | Measurement range / Display specification                                                                                                                                                                                                            |                                                                   | Current input | Voltage input | Intrinsic error <sup>(49)</sup> |                                            | Maximum measurement | Minimum measurement | Note                                                                                                                           |
|-----------------------------------------|------------------------------------------------------------------------------------------------------------------------------------------------------------------------------------------------------------------------------------------------------|-------------------------------------------------------------------|---------------|---------------|---------------------------------|--------------------------------------------|---------------------|---------------------|--------------------------------------------------------------------------------------------------------------------------------|
|                                         |                                                                                                                                                                                                                                                      |                                                                   |               |               | Digital display                 | Analog output Pulse output <sup>(50)</sup> |                     |                     |                                                                                                                                |
| Harmonic nth content                    | Voltage                                                                                                                                                                                                                                              | 0.0~20.0%<br>n=3, 4, 5, 7, 9, 11, 13, 15<br>RY-YB <sup>(57)</sup> |               | ○             | ±1.0%                           | ±2.5%                                      | ○                   |                     | Digital display is % to 100% of content.                                                                                       |
|                                         | Current                                                                                                                                                                                                                                              | 0.0~100.0%<br>n=3, 4, 5, 7, 9, 11, 13, 15<br>R-B <sup>(58)</sup>  | ○             |               | ±2.5%                           | ±2.5%                                      | ○                   |                     |                                                                                                                                |
| Harmonic 5th conversion effective value | Voltage                                                                                                                                                                                                                                              | AC150V~750.0kV<br>(34 range) RY-YB <sup>(57)</sup>                |               | ○             | ±1.5%                           | ±1.5%                                      | ○                   |                     | Digital display is % to a voltage range.                                                                                       |
|                                         | Current                                                                                                                                                                                                                                              | AC5.00A~30.0kA<br>(76 range) R-B <sup>(58)</sup>                  | ○             |               | ±1.5%                           | ±1.5%                                      | ○                   |                     | Digital display is % to a current range.                                                                                       |
| Harmonic 5th conversion content         | Voltage                                                                                                                                                                                                                                              | 0.0~20.0% RY-YB <sup>(57)</sup>                                   |               | ○             | ±1.0%                           | ±2.5%                                      | ○                   |                     | Digital display is % to 100% of content.                                                                                       |
|                                         | Current                                                                                                                                                                                                                                              | 0.0~100.0% R-B <sup>(58)</sup>                                    | ○             |               | ±2.5%                           | ±2.5%                                      | ○                   |                     |                                                                                                                                |
| Watt-hour                               | Display : Integer, 5 digit.<br>Multiplier : Integral number times of 10.<br>Possible to indicate it to 3 decimal place.<br>Electric power is integrated. (Power receiving, Power transmission)                                                       |                                                                   |               |               | Power factor 1 : ±2.0%          | Power factor 1 : ±2.0%                     |                     |                     | Conformity with normal watt-hour meter.<br>Setting range of pulse output unit (kWh/pulse) is referred to option-specification. |
| var-hour                                | Display : Integer, 5 digit.<br>Multiplier : Integral number times of 10.<br>Possible to indicate it to 3 decimal place.<br>Integrating reactive power of power receiving. (LAG-LEAD)<br>Integrating reactive power of power transmission. (LAG-LEAD) |                                                                   |               |               | Power factor 0 : ±2.5%          | Power factor 0 : ±2.5%                     |                     |                     | Setting range of pulse output unit (kvarh/pulse) is referred to option-specification.                                          |

- Note <sup>(48)</sup> The rated voltage of each phase and W phase is 100V. However, the full scale of a bar graph is 300V.
- Note <sup>(49)</sup> If this unit directly measures an inverter output of cycle control, SCR phase angle control or PWM, an error may increase due to its operation principle.  
As for harmonic 5th conversion effective value and nth harmonic effective value, a display will be zero by 0.2% or less of the measurement range. And, analog output constitutes lower limit output. At this time, a distortion factor, harmonic 5th conversion content rate, and nth harmonic content also become 0% (analog output is lower limit output). As for a distortion factor, harmonic 5th conversion effective value / content, and nth harmonic effective value / content, fundamental-wave effective value constitutes zero by 3% or less of the measurement range.
- Note <sup>(50)</sup> Analog output and pulse output are options.  
Analog output of harmonic distortion factor and harmonic content : It becomes an upper limit output from a lower limit output, for current 0~100% and voltage 0~20%.  
The analog output of current leakage constitutes an upper limit output to leakage sensitivity current value. (Only with leakage measurement)
- Note <sup>(51)</sup> Single-phase 3-wire : RW-BW-RB, Single-phase 2-wire : With no phase display.
- Note <sup>(52)</sup> Single-phase 3-wire : R-B-W, Single-phase 2-wire : With no phase display.
- Note <sup>(53)</sup> At the case of one side swing setting of bar graph. Digital meter measures reverse power to -15% full scale. (Instantaneous power)
- Note <sup>(54)</sup> Active power, reactive power display digit.  
A full scale display is below 4000 : 4 digits display. A full scale display is 4000 or more : 3 digits display.  
Example) 4800kW → 4.80MW  
          40kvar → 40.0kvar  
          20kW → 20.00kW      Please refer to an appendix table for details.
- Note <sup>(55)</sup> Only with leakage measurement. However, current input product constitute only I<sub>o</sub> method.
- Note <sup>(56)</sup> The error of ZCT is not included. However, leakage detection sensitivity current below 0.1A constitutes ±0.0025A (ZCT primary).
- Note <sup>(57)</sup> Single-phase 3-wire : RW-BW, single-phase 2-wire : With no phase display, line display.
- Note <sup>(58)</sup> Single-phase 3-wire : R-B, single-phase 2-wire : With no phase display
- Note <sup>(59)</sup> The maximum value (maximum demand current, others) minimum value can be checked in the maximum and the minimum measurement mode.

| Item                                            | Specification                                                                                                                                                                                                                                                                                                                                                                                                                                                                                                                                                                                                                                                                                                              |                                                                                                                                                                                                                                                                                                                                                                                       |
|-------------------------------------------------|----------------------------------------------------------------------------------------------------------------------------------------------------------------------------------------------------------------------------------------------------------------------------------------------------------------------------------------------------------------------------------------------------------------------------------------------------------------------------------------------------------------------------------------------------------------------------------------------------------------------------------------------------------------------------------------------------------------------------|---------------------------------------------------------------------------------------------------------------------------------------------------------------------------------------------------------------------------------------------------------------------------------------------------------------------------------------------------------------------------------------|
| Bar graph display                               | Bar graph display of the main-monitor factor is done. (Watt-hour and var-hour exclude)<br>A display of a sub-monitor factor can also be set.                                                                                                                                                                                                                                                                                                                                                                                                                                                                                                                                                                               |                                                                                                                                                                                                                                                                                                                                                                                       |
| Operating method                                | Current, Voltage : Effective value computing type.<br>Demand ammeter : Arithmetic method according with bimetallic type.<br>Demand active power meter : Arithmetic method according with bimetallic type, or average value within the demand time limit. (One side is selected by setting.)<br>Active power, Reactive power, Watt-hour, var-hour : Time-division multiplication method.<br>Power factor : Average value within instant measurement or the demand time limit. (One side is selected by setting.) Calculates for active power and reactive power.<br>Frequency : Zero cross cycle computing type.<br>Current leakage : Fundamental-wave effective-value arithmetic method.<br>Harmonic : FFT computing type. |                                                                                                                                                                                                                                                                                                                                                                                       |
| Interval setting                                | Demand current                                                                                                                                                                                                                                                                                                                                                                                                                                                                                                                                                                                                                                                                                                             | 0 second / 5 seconds / 10 seconds / 20 seconds / 30 seconds / 40 seconds / 50 seconds / 1 minute / 2 minutes / 3 minutes / 4 minutes / 5 minutes / 6 minutes / 7 minutes                                                                                                                                                                                                              |
|                                                 | Demand active power                                                                                                                                                                                                                                                                                                                                                                                                                                                                                                                                                                                                                                                                                                        | / 8 minutes / 9 minutes / 10 minutes / 15 minutes / 20 minutes / 25 minutes / 30 minutes (95% time limit)                                                                                                                                                                                                                                                                             |
|                                                 | Harmonic measurement                                                                                                                                                                                                                                                                                                                                                                                                                                                                                                                                                                                                                                                                                                       | Average time limit: 0 minute / 1 minute / 2 minutes / 5 minutes / 10 minutes / 15 minutes / 30 minutes Average measurement.                                                                                                                                                                                                                                                           |
| The factor in which display setting is possible | Main monitor                                                                                                                                                                                                                                                                                                                                                                                                                                                                                                                                                                                                                                                                                                               | Voltage (RY-YB-BR), Current (R-Y-B), Demand current (R-Y-B), Active power, Demand active power, Reactive power, Power factor, Frequency, Current leakage, Watt-hour (Power receiving, Power transmission), var-hour (Power receiving LAG/LEAD, Power transmission LAG/LEAD), Distortion factor (A, V)                                                                                 |
|                                                 | Sub-monitor (Left)                                                                                                                                                                                                                                                                                                                                                                                                                                                                                                                                                                                                                                                                                                         | Voltage (RY-YB-BR), Current (R-Y-B), Active power, Reactive power, Power factor, Current leakage                                                                                                                                                                                                                                                                                      |
|                                                 | Sub-monitor (Center)                                                                                                                                                                                                                                                                                                                                                                                                                                                                                                                                                                                                                                                                                                       | Voltage (RY-YB-BR), Current (R-Y-B), Demand current (R-Y-B), Active power, Demand active power, Reactive power, var-hour (Power receiving LAG/LEAD, Power transmission LAG/LEAD), Harmonic 5th conversion content (A, V), Harmonic nth content (A, V)                                                                                                                                 |
|                                                 | Sub-monitor (Right)                                                                                                                                                                                                                                                                                                                                                                                                                                                                                                                                                                                                                                                                                                        | Voltage (RY-YB-BR), Current (R-Y-B), Demand current (R-Y-B), Active power, Demand active power, Power factor, Frequency, Watt-hour (Power receiving, Power transmission), Fundamental-wave effective value (A, V), Harmonic 5th conversion content (A, V), Harmonic nth effective value (A, V)                                                                                        |
|                                                 | Bar graph                                                                                                                                                                                                                                                                                                                                                                                                                                                                                                                                                                                                                                                                                                                  | Voltage (RY-YB-BR), Current (R-Y-B), Demand current (R-Y-B), Active power, Demand active power, Reactive power, Power factor, Frequency, Current leakage, Distortion factor (A, V), Harmonic 5th conversion content (A, V), Harmonic nth content (A, V), Fundamental-wave effective value (A, V), Harmonic 5th conversion effective value (A, V), Harmonic nth effective value (A, V) |
| Option                                          | Analog output (4 sets)<br>Contact output (2 sets. Select of pulse output or alarm output or CPU error output.)<br>External operation change input (2 sets)                                                                                                                                                                                                                                                                                                                                                                                                                                                                                                                                                                 |                                                                                                                                                                                                                                                                                                                                                                                       |

● About power and reactive power full scale range selection

The power range and reactive power range is automatically decided in a current range and voltage range.

The full scale range of a bar graph can be selected out of the following values within a 40~115% (range of power) and 30~115% (range of reactive power), assuming that the rated power (VT ratio × CT ratio)<sup>(60)</sup> is 100%.

1. 0/1. 2/1. 4/1. 5/1. 6/1. 8/2. 0/2. 4/2. 5/2. 8/3. 0/3. 2/3. 6/4. 0/4. 2/4. 5/4. 8/5. 0/5. 6/6. 0/6. 4/7. 2/7. 5/8. 0/8. 4/9. 0/9. 6 × 10<sup>n</sup>

Example ) In case of VT ratio × CT ratio = 1200kW

A full scale range can be selected from the following.  
480/500/560/600/640/720/750/800/840/900/960/1000/1200

Note <sup>(60)</sup> Assume VT ratio is “2” for calculation in case of 220V input specifications and also assume CT ratio is CT ratio ÷ 5 in case of 1A input specifications.



● Measurement is possible range.

| Measurement factor |                 | Input <sup>(61)</sup>                                                                            | Measurement is possible range |                              | Remarks              |  |
|--------------------|-----------------|--------------------------------------------------------------------------------------------------|-------------------------------|------------------------------|----------------------|--|
|                    |                 |                                                                                                  | Display                       | Analog output                |                      |  |
| Voltage            |                 | AC0~150V [AC0~300V]                                                                              | 101% of meter full scale.     | 101% of output span.         |                      |  |
| Current            |                 | AC0~5A [AC0~1A]                                                                                  | 120% of input rating.         | 120% of output span.         | Instant, Demand      |  |
| Power              |                 | 0~1kW (0~200W)<br>[0~2kW (0~400W)]                                                               | 120% of input rating.         | -1% and 120% of output span, | Instant, Demand      |  |
| Reactive power     |                 | LEAD 1~0~LAG 1kvar<br>(LEAD 200~0~LAG 200var)<br>[LEAD 2~0~LAG 2kvar<br>(LEAD 400~0~LAG 400var)] | 120% of input rating.         | -1% and 120% of output span, |                      |  |
| Power factor       |                 | LEAD 0~1~LAG 0                                                                                   | LEAD 0.000~1<br>~LAG 0.000    | 0% and 100% of output span,  |                      |  |
|                    |                 | LEAD 0.5~1~LAG 0.5                                                                               | LEAD 0.490~1<br>~LAG 0.490    | -1% and 101% of output span, |                      |  |
| Frequency          |                 | 45~55Hz                                                                                          | 44.9~55.1Hz                   | -1% and 101% of output span, |                      |  |
|                    |                 | 55~65Hz                                                                                          | 54.9~65.1Hz                   |                              |                      |  |
|                    |                 | 45~65Hz                                                                                          | 44.8~65.2Hz                   |                              |                      |  |
| Current leakage    |                 | AC0~Rated sensitivity<br>current value                                                           | 120% of 0.8A.                 | 120% of output span.         |                      |  |
| Harmonic           | Effective value | Current                                                                                          | AC0~5A [AC0~1A]               | 120% of input rating.        | 120% of output span. |  |
|                    |                 | Voltage                                                                                          | AC0~150V [AC0~300V]           | 101% of meter full scale.    | 101% of output span. |  |
|                    | Rate of content | Current                                                                                          | 0~100%                        | 120%                         | 120% of output span. |  |
|                    |                 | Voltage                                                                                          | 0~20%                         | 100%                         | 120% of output span. |  |

Note <sup>(61)</sup> [ ] is the 300V input case. ( ) is the 1A input case.

## 6.2 Specification, Performance.

| Item                                                        | Specification                                                                                                                                                                                   |                                                                                                                                                     |                                                                                |  |
|-------------------------------------------------------------|-------------------------------------------------------------------------------------------------------------------------------------------------------------------------------------------------|-----------------------------------------------------------------------------------------------------------------------------------------------------|--------------------------------------------------------------------------------|--|
| Accuracy                                                    | Reference to measure specification and accuracy                                                                                                                                                 |                                                                                                                                                     |                                                                                |  |
| Accuracy of bar graph                                       | ±10% (% for span)                                                                                                                                                                               |                                                                                                                                                     |                                                                                |  |
| Influence by temperature                                    | 23±10°C within accuracy.                                                                                                                                                                        |                                                                                                                                                     |                                                                                |  |
| Conformity technical standard                               | JIS C 1102-1, -2, -3, -4, -5, -7 : 1997 , JIS C 1111 : 1989 , JIS C 1216 : 1995 , JIS C 1263 : 1995 , JIS C 8374 : 1991                                                                         |                                                                                                                                                     |                                                                                |  |
| Display updating time                                       | About 1 second (Bar graph : 0.25 seconds)<br>(Current leakage measurement : Digital and bar graph is 2 seconds or less.<br>Harmonic measurement : Digital and bar graph is 10 seconds or less.) |                                                                                                                                                     |                                                                                |  |
| Display device<br>Display composition                       | LCD                                                                                                                                                                                             | Main monitor                                                                                                                                        | 5 digit, character height 11mm                                                 |  |
|                                                             |                                                                                                                                                                                                 | Sub-monitor (Left)                                                                                                                                  | 4 digit, character height 6mm                                                  |  |
|                                                             |                                                                                                                                                                                                 | Sub-monitor (Center), (Right)                                                                                                                       | 5 digit, character height 6mm                                                  |  |
|                                                             |                                                                                                                                                                                                 | Bar graph                                                                                                                                           | 20 dots                                                                        |  |
| LCD view angle                                              | Standard                                                                                                                                                                                        | For upper installation<br>(For lower view)                                                                                                          | Upper view angle 10° , Lower view angle 60° ,<br>Right and left view angle 60° |  |
|                                                             | Special                                                                                                                                                                                         | For lower installation<br>(For upper view)                                                                                                          | Upper view angle 60° , Lower view angle 10° ,<br>Right and left view angle 60° |  |
| Backlight                                                   | LED backlight : Green or White<br>Always-on, Auto off (after 5 minutes without operating), Always-off. Setting is possible.<br>White backlight can select brightness from five steps of 1 to 5. |                                                                                                                                                     |                                                                                |  |
| Auxiliary supply                                            | (1) AC85~264V 50/60Hz 10VA (Rated voltage, AC100/110V, 200/220V)<br>DC80~143V 6W (Rated voltage, DC100/110V) for both AC and DC uses                                                            |                                                                                                                                                     |                                                                                |  |
|                                                             | (2) DC20~56V 6W (Rated voltage, DC24/48V)                                                                                                                                                       |                                                                                                                                                     |                                                                                |  |
| Rush current<br>(Time constant)                             | Rated voltage AC110V 2.2A or less (About 3.6ms)                                                                                                                                                 |                                                                                                                                                     |                                                                                |  |
|                                                             | Rated voltage AC220V 4.4A or less (About 3.6ms)                                                                                                                                                 |                                                                                                                                                     |                                                                                |  |
|                                                             | Rated voltage DC110V 1.6A or less (About 3.6ms)                                                                                                                                                 |                                                                                                                                                     |                                                                                |  |
|                                                             | Rated voltage DC24V 5.0A or less (About 2.0ms)                                                                                                                                                  |                                                                                                                                                     |                                                                                |  |
|                                                             | Rated voltage DC48V 9.9A or less (About 2.0ms)                                                                                                                                                  |                                                                                                                                                     |                                                                                |  |
| Input consumption VA                                        | Voltage circuit                                                                                                                                                                                 | 0.1VA or less (110V) , 0.2VA or less (220V)                                                                                                         |                                                                                |  |
|                                                             | Current circuit                                                                                                                                                                                 | 0.1VA or less (5A, 1A)                                                                                                                              |                                                                                |  |
| Overload capacity                                           | Voltage circuit                                                                                                                                                                                 | 2 times 10 seconds, 1.2 times continuation of rated voltage.                                                                                        |                                                                                |  |
|                                                             | Current circuit                                                                                                                                                                                 | 40 times 1 second, 20 times 4 seconds, 10 times 16 seconds,<br>1.2 times continuation of rated current.                                             |                                                                                |  |
|                                                             | Auxiliary supply                                                                                                                                                                                | 1.5 times 10 seconds, 1.2 times continuation of rated voltage.<br>In case of DC110V, 1.5 times 10 seconds, 1.3 times continuation of rated voltage. |                                                                                |  |
| Insulation resistance<br>JIS C 1102-1<br>JIS C 1111<br>(62) | Between electric circuits and case (Earth).                                                                                                                                                     |                                                                                                                                                     | Above 50MΩ at DC500V megger                                                    |  |
|                                                             | Between input and output and auxiliary supply.                                                                                                                                                  |                                                                                                                                                     |                                                                                |  |
|                                                             | Between analog output and pulse output and alarm output.                                                                                                                                        |                                                                                                                                                     |                                                                                |  |
|                                                             | Between pulse outputs.                                                                                                                                                                          |                                                                                                                                                     |                                                                                |  |
|                                                             | Between alarm outputs.                                                                                                                                                                          |                                                                                                                                                     |                                                                                |  |
| Between analog outputs.                                     |                                                                                                                                                                                                 | Non-insulation (minus common)                                                                                                                       | Designation                                                                    |  |
|                                                             |                                                                                                                                                                                                 | Above 50MΩ at DC500V megger                                                                                                                         |                                                                                |  |
| Withstand voltage (62)<br>JIS C 1102-1<br>JIS C 1111        | Between electric circuits and case (Earth).                                                                                                                                                     |                                                                                                                                                     | AC2000V (50/60Hz) 1 minute                                                     |  |
|                                                             | Between input and output and auxiliary supply.                                                                                                                                                  |                                                                                                                                                     |                                                                                |  |
|                                                             | Between analog output and pulse output and alarm output.                                                                                                                                        |                                                                                                                                                     | AC1500V (50/60Hz) 1 minute                                                     |  |
|                                                             | Between pulse outputs.                                                                                                                                                                          |                                                                                                                                                     |                                                                                |  |
|                                                             | Between alarm outputs.                                                                                                                                                                          |                                                                                                                                                     |                                                                                |  |
| Between analog outputs.                                     |                                                                                                                                                                                                 | Non-insulation (minus common)                                                                                                                       | Designation                                                                    |  |
|                                                             |                                                                                                                                                                                                 | AC500V (50/60Hz) 1 minute                                                                                                                           |                                                                                |  |
| Impulse withstand voltage<br>JIS C 1111                     | Between auxiliary supply and case (Earth).<br>(Only with leakage measurement)                                                                                                                   |                                                                                                                                                     | 7kV 1.2/50μs Positive and negative polarities, for each 3 time.                |  |
|                                                             | Between electric circuits and case (Earth).<br>(An analog output is excluded)                                                                                                                   |                                                                                                                                                     | 6kV 1.2/50μs Positive and negative polarities, for each 3 time.                |  |
|                                                             | Between analog output and case (Earth).                                                                                                                                                         |                                                                                                                                                     | 5kV 1.2/50μs Positive and negative polarities, for each 3 time.                |  |

Note (62) A voltage input and a leakage input are not insulated. Please use it combining ZCT.

| Item                                                       | Specification                                                                                                                                                                                                                                                                                                                                                                                                                                                                                                                                                                                                                                                                                                                                                                                                                                                                                                                                                                                                                                                                                                                                                                                                                                                                                                                                                                        |
|------------------------------------------------------------|--------------------------------------------------------------------------------------------------------------------------------------------------------------------------------------------------------------------------------------------------------------------------------------------------------------------------------------------------------------------------------------------------------------------------------------------------------------------------------------------------------------------------------------------------------------------------------------------------------------------------------------------------------------------------------------------------------------------------------------------------------------------------------------------------------------------------------------------------------------------------------------------------------------------------------------------------------------------------------------------------------------------------------------------------------------------------------------------------------------------------------------------------------------------------------------------------------------------------------------------------------------------------------------------------------------------------------------------------------------------------------------|
| Noise-capacity<br>ANSI C37.90a<br>JEA B-402<br>IEC801-2    | (1) Oscillatory surge voltage<br>If a vibration damping waveform (1~1.5MHz, Peak voltage : 2.5~3kV) is repeated and added, a measurement error should be within 10%. And, there needs to be no malfunction.<br>Voltage input circuit (Normal / Common),<br>Current input circuit (Common. Zero-phase current input circuit is excluded.)<br>Auxiliary supply circuit (Normal / Common)<br>(2) Square wave impulse noise<br>If a noise (1 $\mu$ s, 100ns width) is repeated and added, a measurement error should be within 10%. And, there needs to be no malfunction.<br>Auxiliary supply circuit (Normal / Common) Over 1500V<br>Voltage input circuit (Normal / Common) Over 1500V<br>Current input circuit (Common) Over 1500V (Zero-phase current input circuit is excluded)<br>Pulse output (Common) Over 1000V<br>Alarm output (Common) Over 1000V<br>Operation input (Common) Over 1000V<br>Analog output circuit (Induction) Over 1000V<br>(3) Electric wave noise<br>If intermittence irradiation of the electric wave of a 150,400,900MHz band is done by (5W, 1m), a measurement error should be within 10%. And, there needs to be no malfunction.<br>(4) Electrostatic noise<br>It is within 10% of errors in 8kV electrostatic noise at the case of an energization.<br>There needs to be no 10kV damage at the case of a non-energization.<br>Condenser charge form. |
| Vibration, Shock<br>JIS C 1102-1<br>JIS C 0040, JIS C 0041 | Vibration : Single amplitude 0.15mm, 10~55Hz, Each minute octave in 5 times sweep<br>Shock : 490m/s <sup>2</sup> It is each 3 times to the X,Y,Z direction.                                                                                                                                                                                                                                                                                                                                                                                                                                                                                                                                                                                                                                                                                                                                                                                                                                                                                                                                                                                                                                                                                                                                                                                                                          |
| Construction                                               | Dimension : 110mm(Width) × 110mm(Height) × 103.5mm(Depth) Body diameter : 99mm $\phi$<br>With terminal cover                                                                                                                                                                                                                                                                                                                                                                                                                                                                                                                                                                                                                                                                                                                                                                                                                                                                                                                                                                                                                                                                                                                                                                                                                                                                         |
| Material                                                   | Case, Cover : ABS(V-0) , Terminal block : PBT , Terminal cover : Polycarbonate                                                                                                                                                                                                                                                                                                                                                                                                                                                                                                                                                                                                                                                                                                                                                                                                                                                                                                                                                                                                                                                                                                                                                                                                                                                                                                       |
| Color                                                      | Black (Munsell N1.5)                                                                                                                                                                                                                                                                                                                                                                                                                                                                                                                                                                                                                                                                                                                                                                                                                                                                                                                                                                                                                                                                                                                                                                                                                                                                                                                                                                 |
| Mass                                                       | Approx. 600g                                                                                                                                                                                                                                                                                                                                                                                                                                                                                                                                                                                                                                                                                                                                                                                                                                                                                                                                                                                                                                                                                                                                                                                                                                                                                                                                                                         |
| Blackout guarantee                                         | Maximum value, Minimum value, Integrates value and each setting value.<br>Data hold by nonvolatile memory.                                                                                                                                                                                                                                                                                                                                                                                                                                                                                                                                                                                                                                                                                                                                                                                                                                                                                                                                                                                                                                                                                                                                                                                                                                                                           |
| Operating temperature and humidity limits                  | -10 to +55°C, 30 to 85% RH, Non condensing.                                                                                                                                                                                                                                                                                                                                                                                                                                                                                                                                                                                                                                                                                                                                                                                                                                                                                                                                                                                                                                                                                                                                                                                                                                                                                                                                          |
| Storage temperature limits                                 | -25 to +70°C                                                                                                                                                                                                                                                                                                                                                                                                                                                                                                                                                                                                                                                                                                                                                                                                                                                                                                                                                                                                                                                                                                                                                                                                                                                                                                                                                                         |

6.3 Option

| Item                              | Specification                                                                                                                                                                                                                                                                                                                                                                                                                                                                                                                                                                                                                                                                                                                                                                                                                                                                                                                    |                                                                                                                                                                                                                                                                                                                                                                                                                                                                                                                                                              |                                        |       |                               |                                                                                                |  |
|-----------------------------------|----------------------------------------------------------------------------------------------------------------------------------------------------------------------------------------------------------------------------------------------------------------------------------------------------------------------------------------------------------------------------------------------------------------------------------------------------------------------------------------------------------------------------------------------------------------------------------------------------------------------------------------------------------------------------------------------------------------------------------------------------------------------------------------------------------------------------------------------------------------------------------------------------------------------------------|--------------------------------------------------------------------------------------------------------------------------------------------------------------------------------------------------------------------------------------------------------------------------------------------------------------------------------------------------------------------------------------------------------------------------------------------------------------------------------------------------------------------------------------------------------------|----------------------------------------|-------|-------------------------------|------------------------------------------------------------------------------------------------|--|
| Analog output                     | Number of output                                                                                                                                                                                                                                                                                                                                                                                                                                                                                                                                                                                                                                                                                                                                                                                                                                                                                                                 | 4 circuits                                                                                                                                                                                                                                                                                                                                                                                                                                                                                                                                                   |                                        |       |                               |                                                                                                |  |
|                                   | Output specification                                                                                                                                                                                                                                                                                                                                                                                                                                                                                                                                                                                                                                                                                                                                                                                                                                                                                                             | Analog output non-insulation type                                                                                                                                                                                                                                                                                                                                                                                                                                                                                                                            |                                        |       | Analog output insulation type |                                                                                                |  |
|                                   |                                                                                                                                                                                                                                                                                                                                                                                                                                                                                                                                                                                                                                                                                                                                                                                                                                                                                                                                  | DC4~20mA (Below 550Ω)<br>DC0~1mA (Below 10kΩ)<br>DC0~5V/1~5V (Over 600Ω)<br>DC0~10V (Over 2kΩ)<br>One of them is designated by identical ratings.                                                                                                                                                                                                                                                                                                                                                                                                            |                                        |       |                               | DC4~20mA (Below 550Ω)<br>DC1~5V (Over 600Ω)<br>One of them is designated by identical ratings. |  |
|                                   | Output factor                                                                                                                                                                                                                                                                                                                                                                                                                                                                                                                                                                                                                                                                                                                                                                                                                                                                                                                    | Voltage (RY-YB-BR), Current (R-Y-B), Demand current (R-Y-B), Active power, Demand active power, Reactive power, Power factor, Frequency, Current leakage (Only with leakage measurement), Distortion factor (A, V), Fundamental-wave effective value (Maximum value of each A/V phase), Harmonic 5th conversion content (Maximum value of each A/V phase), Harmonic 5th conversion effective value (Maximum value of each A/V phase), Harmonic nth content (Maximum value of each A/V phase), nth harmonic effective value (Maximum value of each A/V phase) |                                        |       |                               |                                                                                                |  |
|                                   | Response time                                                                                                                                                                                                                                                                                                                                                                                                                                                                                                                                                                                                                                                                                                                                                                                                                                                                                                                    | 1 second or less (Time within ±1% of final constant value.)<br>Leakage measurement is 2 seconds or less. Harmonic measurement is 10 seconds or less.                                                                                                                                                                                                                                                                                                                                                                                                         |                                        |       |                               |                                                                                                |  |
| Output ripple                     | Within the double precision of accuracy (% for output span)                                                                                                                                                                                                                                                                                                                                                                                                                                                                                                                                                                                                                                                                                                                                                                                                                                                                      |                                                                                                                                                                                                                                                                                                                                                                                                                                                                                                                                                              |                                        |       |                               |                                                                                                |  |
| Pulse output<br>( <sup>64</sup> ) | Possible output : Watt-hour or var-hour.<br>Output form : Optical MOS-FET relay. 1a contact<br>Contact capacity: AC, DC125V, 70mA (Resistance load, inductive load)<br>Pulse width : 250±10ms (Output pulse width when the output pulse period of rated active power constitutes speed more than 2 pulse/second by setting of an voltage measurement range, a current-measurement range, and an output pulse unit is set to 100~130ms.)<br>Setting of output pulse unit is possible by the next range.<br>■ 3-phase 3-wire : Full load power (kW, kvar) = $\sqrt{3} \times \text{Rated voltage (V)} \times \text{Rated current (A)} \times 10^{-3}$<br>■ Single-phase 3-wire : Full load power (kW, kvar) = $2 \times \text{Rated voltage (V)} \times \text{Rated current (A)} \times 10^{-3}$<br>■ Single-phase 2-wire : Full load power (kW, kvar) = $\text{Rated voltage (V)} \times \text{Rated current (A)} \times 10^{-3}$ |                                                                                                                                                                                                                                                                                                                                                                                                                                                                                                                                                              |                                        |       |                               |                                                                                                |  |
|                                   | Full load power (kW, kvar)                                                                                                                                                                                                                                                                                                                                                                                                                                                                                                                                                                                                                                                                                                                                                                                                                                                                                                       |                                                                                                                                                                                                                                                                                                                                                                                                                                                                                                                                                              | Output pulse unit. kWh (kvarh) / pulse |       |                               | Multiplying factor                                                                             |  |
|                                   | Below 1                                                                                                                                                                                                                                                                                                                                                                                                                                                                                                                                                                                                                                                                                                                                                                                                                                                                                                                          | 0.1                                                                                                                                                                                                                                                                                                                                                                                                                                                                                                                                                          | 0.01                                   | 0.001 | 0.0001                        | 0.01 ( <sup>63</sup> )                                                                         |  |
|                                   | Over 1 Below 10                                                                                                                                                                                                                                                                                                                                                                                                                                                                                                                                                                                                                                                                                                                                                                                                                                                                                                                  | 1                                                                                                                                                                                                                                                                                                                                                                                                                                                                                                                                                            | 0.1                                    | 0.01  | 0.001                         | 0.1                                                                                            |  |
|                                   | Over 10 Below 100                                                                                                                                                                                                                                                                                                                                                                                                                                                                                                                                                                                                                                                                                                                                                                                                                                                                                                                | 10                                                                                                                                                                                                                                                                                                                                                                                                                                                                                                                                                           | 1                                      | 0.1   | 0.01                          | 1                                                                                              |  |
|                                   | Over 100 Below 1,000                                                                                                                                                                                                                                                                                                                                                                                                                                                                                                                                                                                                                                                                                                                                                                                                                                                                                                             | 100                                                                                                                                                                                                                                                                                                                                                                                                                                                                                                                                                          | 10                                     | 1     | 0.1                           | 10                                                                                             |  |
|                                   | Over 1,000 Below 10,000                                                                                                                                                                                                                                                                                                                                                                                                                                                                                                                                                                                                                                                                                                                                                                                                                                                                                                          | 1,000                                                                                                                                                                                                                                                                                                                                                                                                                                                                                                                                                        | 100                                    | 10    | 1                             | 100                                                                                            |  |
|                                   | Over 10,000 Below 100,000                                                                                                                                                                                                                                                                                                                                                                                                                                                                                                                                                                                                                                                                                                                                                                                                                                                                                                        | 10,000                                                                                                                                                                                                                                                                                                                                                                                                                                                                                                                                                       | 1,000                                  | 100   | 10                            | 1,000                                                                                          |  |
| Over 100,000 Below 1,000,000      | 100,000                                                                                                                                                                                                                                                                                                                                                                                                                                                                                                                                                                                                                                                                                                                                                                                                                                                                                                                          | 10,000                                                                                                                                                                                                                                                                                                                                                                                                                                                                                                                                                       | 1,000                                  | 100   | 10,000                        |                                                                                                |  |

Note (<sup>63</sup>) Although multiplying factor is 0.01, a multiplying factor display will be 0.1.  
(The place by the integer is 4 digits display. An enlarged display is 4 digits below decimal point.)

Note (<sup>64</sup>) 2 outputs combination is possible, for pulse output and alarm output and CPU error output.  
(CPU error output is 1 point only)

| Item                                  | Specification                                                                                                                                                                                                                                                                                                                                                                                                                                 |                                                                                                                                |                                                                                                                                                                                                                                                                  |                                                                                                                          |
|---------------------------------------|-----------------------------------------------------------------------------------------------------------------------------------------------------------------------------------------------------------------------------------------------------------------------------------------------------------------------------------------------------------------------------------------------------------------------------------------------|--------------------------------------------------------------------------------------------------------------------------------|------------------------------------------------------------------------------------------------------------------------------------------------------------------------------------------------------------------------------------------------------------------|--------------------------------------------------------------------------------------------------------------------------|
| Alarm output<br>( <sup>65</sup> )     | Alarm factor : Demand current, Demand active power, Current leakage, harmonic 5th conversion content, Harmonic nth content, Distortion factor, Voltage, Alarm OFF.<br>Possible to setting one of them.<br>Reset form : Automatic reset or Manual reset (Setting)<br>Output contact : No-voltage a contact (OR of each phase detection)<br>Contact capacity : AC250V 8A, DC125V 0.3A (Resistance load) AC250V 2A, DC125V 0.1A (Inductive load) |                                                                                                                                |                                                                                                                                                                                                                                                                  |                                                                                                                          |
|                                       | Alarm factor                                                                                                                                                                                                                                                                                                                                                                                                                                  | Item                                                                                                                           | Specification                                                                                                                                                                                                                                                    |                                                                                                                          |
|                                       | Demand current,<br>Demand active power                                                                                                                                                                                                                                                                                                                                                                                                        | Function                                                                                                                       | Demand measurement value $\geq$ Upper limit setting value, Alarm display, Alarm output.                                                                                                                                                                          |                                                                                                                          |
|                                       |                                                                                                                                                                                                                                                                                                                                                                                                                                               | Setting accuracy                                                                                                               | $\pm 1.0\%$ (% for full scale)                                                                                                                                                                                                                                   |                                                                                                                          |
|                                       |                                                                                                                                                                                                                                                                                                                                                                                                                                               | Setting range                                                                                                                  | 5~100% to the maximum scale. (1% step)                                                                                                                                                                                                                           |                                                                                                                          |
|                                       | Current leakage<br>(Only with leakage measurement)                                                                                                                                                                                                                                                                                                                                                                                            | Sensitivity current                                                                                                            | 50~100% (% for rated sensitivity current value)                                                                                                                                                                                                                  |                                                                                                                          |
|                                       |                                                                                                                                                                                                                                                                                                                                                                                                                                               | Rated sensitivity current value                                                                                                | 0.03A / 0.05A / 0.1A / 0.2A / 0.4A / 0.8A                                                                                                                                                                                                                        |                                                                                                                          |
|                                       |                                                                                                                                                                                                                                                                                                                                                                                                                                               | Operating time                                                                                                                 | Time-delay type (It exceeds 0.1 seconds and is 2 or less seconds.)                                                                                                                                                                                               |                                                                                                                          |
|                                       | Harmonic 5th conversion content<br><br>Harmonic nth content                                                                                                                                                                                                                                                                                                                                                                                   | Function                                                                                                                       | Measurement value $\geq$ Upper limit setting value, Alarm display, Alarm output. (Detects by the maximum phase)                                                                                                                                                  |                                                                                                                          |
|                                       |                                                                                                                                                                                                                                                                                                                                                                                                                                               | Setting accuracy                                                                                                               | Current : $\pm 2.5\%$ , Voltage : $\pm 1.0\%$ , % to 100% of content rate.                                                                                                                                                                                       |                                                                                                                          |
|                                       |                                                                                                                                                                                                                                                                                                                                                                                                                                               | Setting range                                                                                                                  | Current                                                                                                                                                                                                                                                          | Harmonic 5th conversion content, Harmonic nth content (n=3, 4, 5, 7, 9, 11, 13, 15), Distortion factor. 5~100% (1% step) |
|                                       | Voltage                                                                                                                                                                                                                                                                                                                                                                                                                                       |                                                                                                                                | Harmonic 5th conversion content, Harmonic nth content (n=3, 4, 5, 7, 9, 11, 13, 15), Distortion factor. 1.0~20.0% (0.1% step)                                                                                                                                    |                                                                                                                          |
|                                       | Distortion factor                                                                                                                                                                                                                                                                                                                                                                                                                             | Detection characteristics                                                                                                      | Average value mode : It will detect, if a par measurement value becomes beyond the above setting.<br>Inverse-time-delay mode : It detects in the inverse-time-delay characteristics of instantaneous value (only a harmonic 5th conversion content is possible). |                                                                                                                          |
|                                       | Voltage                                                                                                                                                                                                                                                                                                                                                                                                                                       | Function                                                                                                                       | Measurement value $\geq$ Upper limit setting value, Alarm display, Alarm output. (Detects by the maximum phase)<br>Measurement value $\leq$ Lower limit setting value, Alarm display, Alarm output. (Detects by the minimum phase)                               |                                                                                                                          |
|                                       |                                                                                                                                                                                                                                                                                                                                                                                                                                               | Setting accuracy                                                                                                               | $\pm 1.0\%$ (% for full scale)                                                                                                                                                                                                                                   |                                                                                                                          |
| Setting range                         |                                                                                                                                                                                                                                                                                                                                                                                                                                               | Using a full scale as 150%. 30~150% (1% step)                                                                                  |                                                                                                                                                                                                                                                                  |                                                                                                                          |
| CPU error output<br>( <sup>65</sup> ) | Detection item (Self-diagnostics item)                                                                                                                                                                                                                                                                                                                                                                                                        |                                                                                                                                | Contact composition                                                                                                                                                                                                                                              |                                                                                                                          |
|                                       | (1) Watchdog timer (Inside, outside)<br>(2) RAM check error<br>(3) A/D-conversion error<br>At the case of error detection and not applying for auxiliary supply, an output is ON.<br>It becomes OR output of a detection item.                                                                                                                                                                                                                |                                                                                                                                | b contact                                                                                                                                                                                                                                                        |                                                                                                                          |
| External operation input              | Number of circuits                                                                                                                                                                                                                                                                                                                                                                                                                            | 2 circuits. A function (four types) is changed by setting.                                                                     |                                                                                                                                                                                                                                                                  |                                                                                                                          |
|                                       | Function                                                                                                                                                                                                                                                                                                                                                                                                                                      | Four types of following functions can be operated by adding a voltage signal from the outside in addition to switch operation. |                                                                                                                                                                                                                                                                  |                                                                                                                          |
|                                       | Alarm reset                                                                                                                                                                                                                                                                                                                                                                                                                                   | Alarm output is reset (output OFF).                                                                                            |                                                                                                                                                                                                                                                                  |                                                                                                                          |
|                                       | Maximum / Minimum value reset                                                                                                                                                                                                                                                                                                                                                                                                                 | The maximum/minimum value is reset (it updates to the instantaneous value at the time).                                        |                                                                                                                                                                                                                                                                  |                                                                                                                          |
|                                       | Measurement factor change                                                                                                                                                                                                                                                                                                                                                                                                                     | The measurement display element of the main monitoring is changed.                                                             |                                                                                                                                                                                                                                                                  |                                                                                                                          |
|                                       | Phase change                                                                                                                                                                                                                                                                                                                                                                                                                                  | A phase/lines display of all the current/voltage currently displayed is changed.                                               |                                                                                                                                                                                                                                                                  |                                                                                                                          |
|                                       | Minimum operation pulse width                                                                                                                                                                                                                                                                                                                                                                                                                 | 300ms, Continuation applying is possible.                                                                                      |                                                                                                                                                                                                                                                                  |                                                                                                                          |
| Rated input                           | Input rating becomes the same as that of auxiliary supply.<br>(1) AC100/110V 0.4VA, AC200/220V 1.4VA, DC100/110V 0.4W AC DC two ways.<br>Contact capacity : About 3mA (AC, DC100/110V), About 6mA (AC200/220V)<br>(2) DC24V 0.3W, DC48V 1.2W<br>Contact capacity : About 10mA (DC24V), About 20mA (DC48V)                                                                                                                                     |                                                                                                                                |                                                                                                                                                                                                                                                                  |                                                                                                                          |

Note (<sup>65</sup>) 2 outputs combination is possible, for pulse output and alarm output and CPU error output. (CPU error output is 1 point only)

- Caution on the use of external display selection input (option)  
 External power consumption is 0.4VA at AC110V or 1.4VA at AC220V or 0.4W at DC110V.  
 In case a relay or a switch is used for power-supply supply, please use the thing of about 1mA of the minimum application loads.

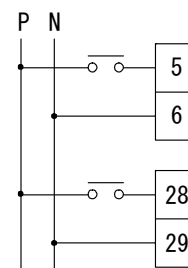

7. Maintenance and check

7.1 Trouble shooting

| Symptoms                                                   | Possible causes                                                                    | Remedial measures                                                                       |
|------------------------------------------------------------|------------------------------------------------------------------------------------|-----------------------------------------------------------------------------------------|
| It does not display.                                       | The power supply is not supplied.<br>(Not connected. or voltage is low)            | Check the auxiliary supply.<br>Again, a power supply is supplied.                       |
|                                                            | Measurement display ON/OFF setting is set to OFF.                                  | Setting check.                                                                          |
|                                                            | Trouble of device.                                                                 | Replace the device.                                                                     |
| Measuring value error is noticeable                        | Range is not set correctly.                                                        | Please set again.                                                                       |
|                                                            | Out of range in rated frequency (45~65Hz).                                         | It cannot be used.                                                                      |
|                                                            | Cycle control, SCR phase angle control, PWM, or other inverter output is measured. | It cannot be used.                                                                      |
| Measurement display of current leakage Igr will be "----". | The direction of the connection to ZCT or this product is reverse.                 | Please do connection correctly.                                                         |
|                                                            | The cable run constitutes a negative phase sequence.                               | Please change a setting (No.163) into "1 : one phase earth (negative phase sequence)" . |
| Analog output is not outputted.                            | Analog output is set to OFF or measurement factor is set to OFF.                   | Please check a setting                                                                  |
| Pulse output is not outputted.                             | Pulse output is set to OFF or measurement factor is set to OFF.                    | Please check a setting                                                                  |
| Alarm output does not return.                              | The return method is a "manual reset".                                             | Please check a setting                                                                  |

7.2 Check

Be careful with the following items periodically.

- (1) Check if the measuring values, scale digits, units, etc. are displayed correctly.
- (2) Check if LCD is free of a color change, breakage of case, or other defects.
- (3) Check the unit for loose wiring and loose mounting screws.
- (4) Please remove, if dust has adhered to the product.

7.3 Maintenance

- (1) Please do not make a wiring change of the input and auxiliary supply in an energization.
- (2) In case you check an output in an energization, please warn to be unable to touch output wiring and a human body to an input and an auxiliary supply terminal. (Please do not short-circuit a voltage output.)
- (3) Please check a connection diagram, in case you check the voltage of input, output, and auxiliary supply.
- (4) If a name-plate is wiped with solvents (an alcoholic nature), a display item may disappear. Please wipe off with the dry cloth.

## 7.4 Test

In case this product is tested, a special setting or operation is not needed fundamentally. However, the following test should operate it along with each process.

### (1) Alarm-output test

Even if this product does not have input, it can perform ON/OFF test of an alarm output (relay-contact output). Operation is performed by alarm 1 test and alarm 2 test in the setting mode 1.

Please refer to "5.3.1 Setting mode 1 (2) alarm-output setup" about the details of operation.

In case an alarm-output factor is a current leakage (Io/Igr).

While pushing SET, the test input exceeding rated sensitivity current value is applied to the zero-phase current input circuit inside a product. If the time that is pushing **SET** exceeds the operating time (it exceeds time-delay form 0.1 seconds, and is 2 or less seconds) of a current leakage, an alarm will occur.

And, test input will become off if **SET** is detached. Please be sure to apply rated voltage to voltage input terminal (between P1-P2) at this time.

In addition, an alarm return constitutes action corresponding to a return method setting (automatic reset / manual reset) of each alarm output.

### < Operating process >

#### • Alarm 1 test (Setting No. 124)

Press **SET** for 3 seconds <sup>(111)</sup> → Press **MODE** <sup>(121)</sup> → Press **RESET/SHIFT** for 3 times <sup>(124)</sup> → While pushing **SET**, the alarm 1 output is ON.

#### • Alarm 2 test (Setting No. 128)

Press **SET** for 3 seconds <sup>(111)</sup> → Press **MODE** <sup>(121)</sup> → Press **RESET/SHIFT** for 7 times <sup>(128)</sup> → While pushing **SET**, the alarm 2 output is ON.

#### • In case an alarm-output factor is current leakage (Io/Igr) ... Example ) ALARM 2

Press **SET** for 3 seconds <sup>(111)</sup> → Press **MODE** <sup>(121)</sup> → Press **RESET/SHIFT** for 7 times <sup>(128)</sup> ┌  
└ → If it continues pushing **SET** for a long time from the current-leakage operating time, alarm 2 output is ON.

### (2) Harmonic time-interval test

Please test by the following operation about the time interval of a harmonic. An error becomes large, in case it tests without performing the following operation.

Operation is performed with the average time interval in the setting mode 1.

Please refer to "5.3.1 setting mode 1 (4) harmonic detection setting" for operation details.

### < Operating process > (Setting No. 14A)

Press **SET** for 3 seconds <sup>(111)</sup> → Press **MODE** for 3 times <sup>(141)</sup> → Press **RESET/SHIFT** for 9 times <sup>(14A)</sup> ┌

└ → Please press **SET** simultaneously with a test start.

Please press **DISPLAY** and return to a measurement screen.

## 7.5 Storage

(1) Please avoid storage in the next space. Low temperature, high temperature, high humidity, and sunny place.

(2) The aluminum electrolytic capacitor is used for a product. Please do the energization of the power supply within one year after shipment.

## 7.6 Countermeasures against troubles

As our principle, we recall product in question and repair it. If judged as product failure, have a contact with us or sales agent for repairing work (Also have a contact with us or sales agent for specification change).

Product failure which we are not responsible for (When responsibility in manufacturing process is not recognized, when product is disassembled/remodeled, in case of false operation by customer, etc.) is beyond our warranty.

Appendix table 1-1

Active power range, watt-hour multiplier rate table (3-phase 3-wire)

| Multiplier rate | V range<br>A range | 750.0kV                | 500.0kV                | 375.0kV                | 300.0kV                | 255.0kV                | 210.0kV                | 180.0kV                | 150.0kV                | 105.0kV               | 90.0kV                | 45.0kV                | 30.0kV                | Multiplier rate |
|-----------------|--------------------|------------------------|------------------------|------------------------|------------------------|------------------------|------------------------|------------------------|------------------------|-----------------------|-----------------------|-----------------------|-----------------------|-----------------|
|                 |                    | (VT550000/110V)<br>[W] | (VT380000/110V)<br>[W] | (VT275000/110V)<br>[W] | (VT220000/110V)<br>[W] | (VT187000/110V)<br>[W] | (VT154000/110V)<br>[W] | (VT132000/110V)<br>[W] | (VT110000/110V)<br>[W] | (VT77000/110V)<br>[W] | (VT66000/110V)<br>[W] | (VT33000/110V)<br>[W] | (VT22000/110V)<br>[W] |                 |
| × 100           | 5A                 | 5.00 M                 | 3600 k<br>(3455)       | 2500 k                 | 2000 k                 | 1800 k<br>(1700)       | 1400 k                 | 1200 k                 | 1000 k                 | 720 k<br>(700)        | 600 k                 | 300.0 k               | 200.0 k               | × 10            |
|                 | 6A                 | 6.00 M                 | 4.20 M<br>(4.15)       | 3000 k                 | 2400 k                 | 2000 k<br>(2040)       | 1800 k<br>(1680)       | 1500 k<br>(1440)       | 1200 k                 | 900 k<br>(840)        | 720 k                 | 360.0 k               | 240.0 k               |                 |
|                 | 7.5A               | 7.50 M                 | 5.60 M<br>(5.18)       | 4.00 M<br>(3.75)       | 3000 k                 | 2500 k<br>(2550)       | 2400 k<br>(2100)       | 1800 k                 | 1500 k                 | 1200 k<br>(1050)      | 900 k                 | 450 k                 | 300.0 k               |                 |
|                 | 8A                 | 8.00 M                 | 5.60 M<br>(5.53)       | 4.00 M                 | 3200 k                 | 3000 k<br>(2720)       | 2400 k<br>(2240)       | 2000 k<br>(1920)       | 1600 k                 | 1200 k<br>(1120)      | 960 k                 | 480 k                 | 320.0 k               |                 |
|                 | 10A                | 10.00 M                | 7.20 M<br>(6.91)       | 5.00 M                 | 4.00 M                 | 3600 k<br>(3400)       | 2800 k                 | 2400 k                 | 2000 k                 | 1400 k                | 1200 k                | 600 k                 | 400 k                 |                 |
|                 | 12A                | 12.00 M                | 8.40 M<br>(8.29)       | 6.00 M                 | 4.80 M                 | 4.20 M<br>(4.08)       | 3600 k<br>(3360)       | 3000 k<br>(2880)       | 2400 k                 | 1800 k<br>(1680)      | 1500 k<br>(1440)      | 720 k                 | 480 k                 |                 |
|                 | 15A                | 15.00 M                | 10.00 M<br>(10.36)     | 7.50 M                 | 6.00 M                 | 5.60 M<br>(5.10)       | 4.20 M                 | 3600 k                 | 3000 k                 | 2400 k<br>(2100)      | 1800 k                | 900 k                 | 600 k                 |                 |
|                 | 20A                | 20.00 M                | 14.00 M<br>(13.82)     | 10.00 M                | 8.00 M                 | 7.20 M<br>(6.80)       | 5.60 M                 | 4.80 M                 | 4.00 M                 | 2800 k                | 2400 k                | 1200 k                | 800 k                 |                 |
|                 | 25A                | 25.00 M                | 18.00 M<br>(17.27)     | 14.00 M<br>(12.50)     | 10.00 M                | 9.00 M<br>(8.50)       | 7.20 M<br>(7.00)       | 6.00 M                 | 5.00 M                 | 3600 k<br>(3500)      | 3000 k                | 1500 k                | 1000 k                |                 |
|                 | 30A                | 30.00 M                | 20.00 M<br>(20.73)     | 15.00 M                | 12.00 M                | 10.00 M<br>(10.20)     | 8.40 M                 | 7.20 M                 | 6.00 M                 | 4.20 M                | 3600 k                | 1800 k                | 1200 k                |                 |
| 40A             | 40.0 M             | 28.00 M<br>(27.64)     | 20.00 M                | 16.00 M                | 14.00 M<br>(13.60)     | 12.00 M<br>(11.20)     | 9.60 M                 | 8.00 M                 | 5.60 M                 | 4.80 M                | 2400 k                | 1600 k                |                       |                 |
| 50A             | 50.0 M             | 36.00 M<br>(34.55)     | 25.00 M                | 20.00 M                | 18.00 M<br>(17.00)     | 14.00 M                | 12.00 M                | 10.00 M                | 7.20 M<br>(7.00)       | 6.00 M                | 3000 k                | 2000 k                |                       |                 |
| 60A             | 60.0 M             | 42.0 M<br>(41.5)       | 30.00 M                | 24.00 M                | 20.00 M<br>(20.40)     | 18.00 M<br>(16.80)     | 15.00 M<br>(14.40)     | 12.00 M                | 8.40 M                 | 7.20 M                | 3600 k                | 2400 k                |                       |                 |
| 75A             | 75.0 M             | 56.0 M<br>(51.8)       | 40.0 M<br>(37.5)       | 30.00 M                | 28.00 M<br>(25.50)     | 24.00 M<br>(21.00)     | 18.00 M                | 15.00 M                | 12.00 M<br>(10.50)     | 9.00 M                | 4.50 M                | 3000 k                |                       |                 |
| 80A             | 80.0 M             | 56.0 M<br>(55.3)       | 40.0 M                 | 32.00 M                | 28.00 M<br>(27.20)     | 24.00 M<br>(22.40)     | 20.00 M<br>(19.20)     | 16.00 M                | 12.00 M<br>(11.20)     | 9.60 M                | 4.80 M                | 3200 k                |                       |                 |
| 100A            | 100.0 M            | 72.0 M<br>(69.1)       | 50.0 M                 | 40.0 M                 | 36.00 M<br>(34.00)     | 28.00 M                | 24.00 M                | 20.00 M                | 14.00 M                | 12.00 M               | 6.00 M                | 4.00 M                |                       |                 |
| 120A            | 120.0 M            | 84.0 M<br>(82.9)       | 60.0 M                 | 48.0 M                 | 42.0 M<br>(40.8)       | 36.00 M<br>(33.60)     | 30.00 M<br>(28.80)     | 24.00 M                | 18.00 M<br>(16.80)     | 15.00 M<br>(14.40)    | 7.20 M                | 4.80 M                |                       |                 |
| 150A            | 150.0 M            | 100.0 M<br>(103.6)     | 75.0 M                 | 60.0 M                 | 56.0 M<br>(51.0)       | 42.0 M                 | 36.00 M                | 30.00 M                | 24.00 M<br>(21.00)     | 18.00 M               | 9.00 M                | 6.00 M                |                       |                 |
| 200A            | 200.0 M            | 140.0 M<br>(138.2)     | 100.0 M                | 80.0 M                 | 72.0 M<br>(68.0)       | 56.0 M                 | 48.0 M                 | 40.0 M                 | 28.00 M                | 24.00 M               | 12.00 M               | 8.00 M                | × 1000                |                 |
| 250A            | 250.0 M            | 180.0 M<br>(172.7)     | 140.0 M<br>(125.0)     | 100.0 M                | 90.0 M<br>(85.0)       | 72.0 M<br>(70.0)       | 60.0 M                 | 50.0 M                 | 36.00 M<br>(35.00)     | 30.00 M               | 15.00 M               | 10.00 M               |                       |                 |
| 300A            | 300.0 M            | 200.0 M<br>(207.3)     | 150.0 M                | 120.0 M                | 100.0 M<br>(102.0)     | 84.0 M                 | 72.0 M                 | 60.0 M                 | 42.0 M                 | 36.00 M               | 18.00 M               | 12.00 M               |                       |                 |
| 400A            | 400 M              | 280.0 M<br>(276.4)     | 200.0 M                | 160.0 M                | 140.0 M<br>(136.0)     | 120.0 M<br>(112.0)     | 96.0 M                 | 80.0 M                 | 56.0 M                 | 48.0 M                | 24.00 M               | 16.00 M               |                       |                 |
| 500A            | 500 M              | 360.0 M<br>(345.5)     | 250.0 M                | 200.0 M                | 180.0 M<br>(170.0)     | 140.0 M                | 120.0 M                | 100.0 M                | 72.0 M<br>(70.0)       | 60.0 M                | 30.00 M               | 20.00 M               |                       |                 |
| 600A            | 600 M              | 420 M<br>(415)         | 300.0 M                | 240.0 M                | 200.0 M<br>(204.0)     | 180.0 M<br>(168.0)     | 150.0 M<br>(144.0)     | 120.0 M                | 84.0 M                 | 72.0 M                | 36.00 M               | 24.00 M               |                       |                 |
| 750A            | 750 M              | 560 M<br>(518)         | 400 M<br>(375)         | 300.0 M                | 280.0 M<br>(255.0)     | 240.0 M<br>(210.0)     | 180.0 M                | 150.0 M                | 120.0 M<br>(105.0)     | 90.0 M                | 45.0 M                | 30.00 M               |                       |                 |
| 800A            | 800 M              | 560 M<br>(553)         | 400 M                  | 320.0 M                | 280.0 M<br>(272.0)     | 240.0 M<br>(224.0)     | 200.0 M<br>(192.0)     | 160.0 M                | 120.0 M<br>(112.0)     | 96.0 M                | 48.0 M                | 32.00 M               |                       |                 |
| 900A            | 900 M              | 640 M<br>(622)         | 450 M                  | 360.0 M                | 320.0 M<br>(306.0)     | 280.0 M<br>(252.0)     | 240.0 M<br>(216.0)     | 180.0 M                | 140.0 M<br>(126.0)     | 120.0 M<br>(108.0)    | 56.0 M<br>(54.0)      | 36.00 M               |                       |                 |
| 1000A           | 1000 M             | 720 M<br>(691)         | 500 M                  | 400 M                  | 360.0 M<br>(340.0)     | 280.0 M                | 240.0 M                | 200.0 M                | 140.0 M                | 120.0 M               | 60.0 M                | 40.0 M                |                       | × 10000         |
| 1200A           |                    | 840 M<br>(829)         | 600 M                  | 480 M                  | 420 M<br>(408)         | 360.0 M<br>(336.0)     | 300.0 M<br>(288.0)     | 240.0 M                | 180.0 M<br>(168.0)     | 150.0 M<br>(144.0)    | 72.0 M                | 48.0 M                |                       |                 |
| 1500A           |                    |                        | 750 M                  | 600 M                  | 560 M<br>(510)         | 420 M                  | 360.0 M                | 300.0 M                | 240.0 M<br>(210.0)     | 180.0 M               | 90.0 M                | 60.0 M                |                       |                 |
| 1600A           |                    |                        | 800 M                  | 640 M                  | 560 M<br>(544)         | 450 M<br>(448)         | 400 M<br>(384)         | 320.0 M                | 240.0 M<br>(224.0)     | 200.0 M<br>(192.0)    | 96.0 M                | 64.0 M                |                       |                 |
| 1800A           |                    |                        | 900 M                  | 720 M                  | 640 M<br>(612)         | 560 M<br>(504)         | 450 M<br>(432)         | 360.0 M                | 280.0 M<br>(252.0)     | 240.0 M<br>(216.0)    | 120.0 M<br>(108.0)    | 72.0 M                |                       |                 |
| 2000A           |                    |                        | 1000 M                 | 800 M                  | 720 M<br>(680)         | 560 M                  | 480 M                  | 400 M                  | 280.0 M                | 240.0 M               | 120.0 M               | 80.0 M                |                       |                 |
| 2500A           |                    |                        |                        | 1000 M                 | 900 M<br>(850)         | 720 M<br>(700)         | 600 M                  | 500 M                  | 360.0 M<br>(350.0)     | 300.0 M               | 150.0 M               | 100.0 M               |                       |                 |
| 3000A           |                    |                        |                        |                        |                        | 840 M                  | 720 M                  | 600 M                  | 420 M                  | 360.0 M               | 180.0 M               | 120.0 M               |                       |                 |
| 4000A           |                    |                        |                        |                        |                        |                        | 960 M                  | 800 M                  | 560 M                  | 480 M                 | 240.0 M               | 160.0 M               |                       |                 |
| 5000A           |                    |                        |                        |                        |                        |                        |                        | 1000 M                 | 720 M<br>(700)         | 600 M                 | 300.0 M               | 200.0 M               |                       |                 |
| 6000A           |                    |                        |                        |                        |                        |                        |                        |                        | 840 M                  | 720 M                 | 360.0 M               | 240.0 M               |                       |                 |
| 7500A           |                    |                        |                        |                        |                        |                        |                        |                        |                        | 900 M                 | 450 M                 | 300.0 M               |                       |                 |
| 8000A           |                    |                        |                        |                        |                        |                        |                        |                        |                        | 960 M                 | 480 M                 | 320.0 M               |                       |                 |
| 9000A           |                    |                        |                        |                        |                        |                        |                        |                        |                        |                       | 560 M<br>(540)        | 360.0 M               |                       |                 |
| 10000A          |                    |                        |                        |                        |                        |                        |                        |                        |                        |                       | 600 M                 | 400 M                 |                       |                 |
| 12000A          |                    |                        |                        |                        |                        |                        |                        |                        |                        |                       | 720 M                 | 480 M                 |                       |                 |
| 15000A          |                    |                        |                        |                        |                        |                        |                        |                        |                        |                       | 900 M                 | 600 M                 |                       |                 |
| 20000A          |                    |                        |                        |                        |                        |                        |                        |                        |                        |                       |                       | 800 M                 |                       |                 |
| 30000A          |                    |                        |                        |                        |                        |                        |                        |                        |                        |                       |                       |                       | × 10000               |                 |

<Note 1>

Parenthesis is primary active power (reactive power) value in /1kW(1kvar).

In the blank, setting is impossible.

About active power and reactive power range.

Full scale display, less than 4000 : 4 digit. More than 4000 : 3 digit.

An example) 4800kW → 4.80MW

40kvar → 40.0kvar

20kW → 20.00kW

<Note 2>

In case the voltage range and the current range were set as [ ] of an upper table and an output pulse unit (a four-step setup is possible) is set as the fastest. The output pulse width of a pulse output is set to 100 ~130ms. (Usually 240~260ms)



Appendix table 1-2

Active power range, watt-hour multiplier rate table (3-phase 3-wire)

| Multiplier rate | V range<br>A range | 25.00kV               | 24.00kV               | 18.00kV               | 18.00kV               | 15.00kV               | 9000V                | 4500V                | 3000V                | 2400V                | 1500V                | 1200V               | 600V                | Multiplier rate |
|-----------------|--------------------|-----------------------|-----------------------|-----------------------|-----------------------|-----------------------|----------------------|----------------------|----------------------|----------------------|----------------------|---------------------|---------------------|-----------------|
|                 |                    | (VT18400/110V)<br>[W] | (VT16500/110V)<br>[W] | (VT13800/110V)<br>[W] | (VT13200/110V)<br>[W] | (VT11000/110V)<br>[W] | (VT6600/110V)<br>[W] | (VT3300/110V)<br>[W] | (VT2200/110V)<br>[W] | (VT1650/110V)<br>[W] | (VT1100/110V)<br>[W] | (VT880/110V)<br>[W] | (VT480/110V)<br>[W] |                 |
| × 10            | 5A                 | 180.0 k<br>(167)      | 150.0 k               | 140.0 k<br>(125.5)    | 120.0 k               | 100.0 k               | 60.0 k               | 30.00 k              | 20.00 k              | 15.00 k              | 10.00 k              | 8.00 k              | 4.50 k<br>(4.36)    | × 0.1           |
|                 | 6A                 | 200.0 k<br>(201)      | 180.0 k               | 160.0 k<br>(150.5)    | 150.0 k<br>(144.0)    | 120.0 k               | 72.0 k               | 36.00 k              | 24.00 k              | 18.00 k              | 12.00 k              | 9.60 k              | 5.60 k<br>(5.24)    |                 |
|                 | 7.5A               | 280.0 k<br>(251)      | 240.0 k<br>(225.0)    | 200.0 k<br>(188.2)    | 180.0 k               | 150.0 k               | 90.0 k               | 45.0 k               | 30.00 k              | 24.00 k<br>(22.50)   | 15.00 k              | 12.00 k             | 7.20 k<br>(6.55)    |                 |
|                 | 8A                 | 280.0 k<br>(268)      | 240.0 k               | 200.0 k<br>(200.7)    | 200.0 k<br>(192.0)    | 160.0 k               | 96.0 k               | 48.0 k               | 32.00 k              | 24.00 k              | 16.00 k              | 14.00 k<br>(12.80)  | 7.20 k<br>(6.98)    |                 |
|                 | 10A                | 360.0 k<br>(335)      | 300.0 k               | 280.0 k<br>(250.9)    | 240.0 k               | 200.0 k               | 120.0 k              | 60.0 k               | 40.0 k               | 30.00 k              | 20.00 k              | 16.00 k             | 9.00 k<br>(8.73)    |                 |
|                 | 12A                | 420 k<br>(401)        | 360.0 k               | 320.0 k<br>(301.1)    | 300.0 k<br>(288.0)    | 240.0 k               | 150.0 k<br>(144.0)   | 72.0 k               | 48.0 k               | 36.00 k              | 24.00 k              | 20.00 k<br>(19.20)  | 12.00 k<br>(10.47)  |                 |
|                 | 15A                | 560 k<br>(502)        | 450 k                 | 400 k<br>(376)        | 360.0 k               | 300.0 k               | 180.0 k              | 90.0 k               | 60.0 k               | 45.0 k               | 30.00 k              | 24.00 k             | 14.00 k<br>(13.09)  |                 |
|                 | 20A                | 720 k<br>(669)        | 600 k                 | 560 k<br>(502)        | 480 k                 | 400 k                 | 240.0 k              | 120.0 k              | 80.0 k               | 60.0 k               | 40.0 k               | 32.00 k             | 18.00 k<br>(17.45)  |                 |
|                 | 25A                | 840 k<br>(836)        | 750 k                 | 640 k<br>(627)        | 600 k                 | 500 k                 | 300.0 k              | 150.0 k              | 100.0 k              | 75.0 k               | 50.0 k               | 40.0 k              | 24.00 k<br>(21.82)  |                 |
|                 | × 100              | 30A                   | 1000 k<br>(1004)      | 900 k                 | 800 k<br>(753)        | 720 k                 | 600 k                | 360.0 k              | 180.0 k              | 120.0 k              | 90.0 k               | 60.0 k              | 48.0 k              |                 |
| 40A             |                    | 1400 k<br>(1338)      | 1200 k                | 1000 k<br>(1004)      | 960 k                 | 800 k                 | 480 k                | 240.0 k              | 160.0 k              | 120.0 k              | 80.0 k               | 64.0 k              | 36.00 k<br>(34.91)  |                 |
| 50A             |                    | 1800 k<br>(1673)      | 1500 k                | 1400 k<br>(1255)      | 1200 k                | 1000 k                | 600 k                | 300.0 k              | 200.0 k              | 150.0 k              | 100.0 k              | 80.0 k              | 45.0 k<br>(43.6)    |                 |
| 60A             |                    | 2000 k<br>(2007)      | 1800 k                | 1600 k<br>(1505)      | 1500 k<br>(1440)      | 1200 k                | 720 k                | 360.0 k              | 240.0 k              | 180.0 k              | 120.0 k              | 96.0 k              | 56.0 k<br>(52.4)    |                 |
| 75A             |                    | 2800 k<br>(2509)      | 2400 k<br>(2250)      | 2000 k<br>(1882)      | 1800 k                | 1500 k                | 900 k                | 450 k                | 300.0 k              | 240.0 k<br>(225.0)   | 150.0 k              | 120.0 k             | 72.0 k<br>(65.5)    |                 |
| 80A             |                    | 2800 k<br>(2676)      | 2400 k                | 2000 k<br>(2007)      | 2000 k<br>(1920)      | 1600 k                | 960 k                | 480 k                | 320.0 k              | 240.0 k              | 160.0 k              | 140.0 k<br>(128.0)  | 72.0 k<br>(69.8)    |                 |
| 100A            |                    | 3600 k<br>(3345)      | 3000 k                | 2800 k<br>(2509)      | 2400 k                | 2000 k                | 1200 k               | 600 k                | 400 k                | 300.0 k              | 200.0 k              | 160.0 k             | 90.0 k<br>(87.3)    |                 |
| 120A            |                    | 4.20 M<br>(4.01)      | 3600 k                | 3200 k<br>(3011)      | 3000 k<br>(2880)      | 2400 k                | 1500 k<br>(1440)     | 720 k                | 480 k                | 360.0 k              | 240.0 k              | 200.0 k<br>(192.0)  | 120.0 k<br>(104.7)  |                 |
| 150A            |                    | 5.60 M<br>(5.02)      | 4.50 M                | 4.00 M<br>(3.76)      | 3600 k                | 3000 k                | 1800 k               | 900 k                | 600 k                | 450 k                | 300.0 k              | 240.0 k             | 140.0 k<br>(130.9)  |                 |
| 200A            |                    | 7.20 M<br>(6.69)      | 6.00 M                | 5.60 M<br>(5.02)      | 4.80 M                | 4.00 M                | 2400 k               | 1200 k               | 800 k                | 600 k                | 400 k                | 320.0 k             | 180.0 k<br>(174.5)  |                 |
| × 1000          | 250A               | 8.40 M<br>(8.36)      | 7.50 M                | 6.40 M<br>(6.27)      | 6.00 M                | 5.00 M                | 3000 k               | 1500 k               | 1000 k               | 750 k                | 500 k                | 400 k               | 240.0 k<br>(218.2)  | × 10            |
|                 | 300A               | 10.00 M<br>(10.04)    | 9.00 M                | 8.00 M<br>(7.53)      | 7.20 M                | 6.00 M                | 3600 k               | 1800 k               | 1200 k               | 900 k                | 600 k                | 480 k               | 280.0 k<br>(261.8)  |                 |
|                 | 400A               | 14.00 M<br>(13.38)    | 12.00 M               | 10.00 M<br>(10.04)    | 9.60 M                | 8.00 M                | 4.80 M               | 2400 k               | 1600 k               | 1200 k               | 800 k                | 640 k               | 360.0 k<br>(349.1)  |                 |
|                 | 500A               | 18.00 M<br>(16.73)    | 15.00 M               | 14.00 M<br>(12.55)    | 12.00 M               | 10.00 M               | 6.00 M               | 3000 k               | 2000 k               | 1500 k               | 1000 k               | 800 k               | 450 k<br>(436)      |                 |
|                 | 600A               | 20.00 M<br>(20.07)    | 18.00 M               | 16.00 M<br>(15.05)    | 15.00 M<br>(14.40)    | 12.00 M               | 7.20 M               | 3600 k               | 2400 k               | 1800 k               | 1200 k               | 960 k               | 560 k<br>(524)      |                 |
|                 | 750A               | 28.00 M<br>(25.09)    | 24.00 M<br>(22.50)    | 20.00 M<br>(18.82)    | 18.00 M               | 15.00 M               | 9.00 M               | 4.50 M               | 3000 k               | 2400 k<br>(2250)     | 1500 k               | 1200 k              | 720 k<br>(655)      |                 |
|                 | 800A               | 28.00 M<br>(26.76)    | 24.00 M               | 20.00 M<br>(20.07)    | 20.00 M<br>(19.20)    | 16.00 M               | 9.60 M               | 4.80 M               | 3200 k               | 2400 k               | 1600 k               | 1400 k<br>(1280)    | 720 k<br>(698)      |                 |
|                 | 900A               | 32.00 M<br>(30.11)    | 28.00 M<br>(27.00)    | 24.00 M<br>(22.58)    | 24.00 M<br>(21.60)    | 18.00 M               | 12.00 M<br>(10.80)   | 5.60 M<br>(5.40)     | 3600 k               | 2800 k<br>(2700)     | 1800 k               | 1500 k<br>(1440)    | 900 k<br>(785)      |                 |
|                 | 1000A              | 36.00 M<br>(33.45)    | 30.00 M               | 28.00 M<br>(25.09)    | 24.00 M               | 20.00 M               | 12.00 M              | 6.00 M               | 4.00 M               | 3000 k               | 2000 k               | 1600 k              | 900 k<br>(873)      |                 |
|                 | 1200A              | 42.0 M<br>(40.1)      | 36.00 M               | 32.00 M<br>(30.11)    | 30.00 M<br>(28.80)    | 24.00 M               | 15.00 M<br>(14.40)   | 7.20 M               | 4.80 M               | 3600 k               | 2400 k               | 2000 k<br>(1920)    | 1200 k<br>(1047)    |                 |
| × 10000         | 1500A              | 56.0 M<br>(50.2)      | 45.0 M                | 40.0 M<br>(37.6)      | 36.00 M               | 30.00 M               | 18.00 M              | 9.00 M               | 6.00 M               | 4.50 M               | 3000 k               | 2400 k              | 1400 k<br>(1309)    | × 100           |
|                 | 1600A              | 56.0 M<br>(53.5)      | 48.0 M                | 42.0 M<br>(40.1)      | 40.0 M<br>(38.4)      | 32.00 M               | 20.00 M<br>(19.20)   | 9.60 M               | 6.40 M               | 4.80 M               | 3200 k               | 2800 k<br>(2560)    | 1400 k<br>(1396)    |                 |
|                 | 1800A              | 64.0 M<br>(60.2)      | 56.0 M<br>(54.0)      | 48.0 M<br>(45.2)      | 45.0 M<br>(43.2)      | 36.00 M               | 24.00 M<br>(21.60)   | 12.00 M<br>(10.80)   | 7.20 M               | 5.60 M<br>(5.40)     | 3600 k               | 2800 k<br>(2880)    | 1600 k<br>(1571)    |                 |
|                 | 2000A              | 72.0 M<br>(66.9)      | 60.0 M                | 56.0 M<br>(50.2)      | 48.0 M                | 40.0 M                | 24.00 M              | 12.00 M              | 8.00 M               | 6.00 M               | 4.00 M               | 3200 k              | 1800 k<br>(1745)    |                 |
|                 | 2500A              | 84.0 M<br>(83.6)      | 75.0 M                | 64.0 M<br>(62.7)      | 60.0 M                | 50.0 M                | 30.00 M              | 15.00 M              | 10.00 M              | 7.50 M               | 5.00 M               | 4.00 M              | 2400 k<br>(2182)    |                 |
|                 | 3000A              | 100.0 M<br>(100.4)    | 90.0 M                | 80.0 M<br>(75.3)      | 72.0 M                | 60.0 M                | 36.00 M              | 18.00 M              | 12.00 M              | 9.00 M               | 6.00 M               | 4.80 M              | 2800 k<br>(2618)    |                 |
|                 | 4000A              | 140.0 M<br>(133.8)    | 120.0 M               | 100.0 M<br>(100.4)    | 96.0 M                | 80.0 M                | 48.0 M               | 24.00 M              | 16.00 M              | 12.00 M              | 8.00 M               | 6.40 M              | 3600 k<br>(3491)    |                 |
|                 | 5000A              | 180.0 M<br>(167.3)    | 150.0 M               | 140.0 M<br>(125.5)    | 120.0 M               | 100.0 M               | 60.0 M               | 30.00 M              | 20.00 M              | 15.00 M              | 10.00 M              | 8.00 M              | 4.50 M<br>(4.36)    |                 |
|                 | 6000A              | 200.0 M<br>(200.7)    | 180.0 M               | 160.0 M<br>(150.5)    | 150.0 M<br>(144.0)    | 120.0 M               | 72.0 M               | 36.00 M              | 24.00 M              | 18.00 M              | 12.00 M              | 9.60 M              | 5.60 M<br>(5.24)    |                 |
|                 | 7500A              | 280.0 M<br>(250.9)    | 240.0 M<br>(225.0)    | 200.0 M<br>(188.2)    | 180.0 M               | 150.0 M               | 90.0 M               | 45.0 M               | 30.00 M              | 24.00 M<br>(22.50)   | 15.00 M              | 12.00 M             | 6.40 M<br>(6.55)    |                 |
| × 100000        | 8000A              | 280.0 M<br>(267.6)    | 240.0 M               | 200.0 M<br>(200.7)    | 200.0 M<br>(192.0)    | 160.0 M               | 96.0 M               | 48.0 M               | 32.00 M              | 24.00 M              | 16.00 M              | 14.00 M<br>(12.80)  | 7.20 M<br>(6.98)    | × 1000          |
|                 | 9000A              | 320.0 M<br>(301.1)    | 280.0 M<br>(270.0)    | 240.0 M<br>(225.8)    | 240.0 M<br>(216.0)    | 180.0 M               | 120.0 M<br>(108.0)   | 56.0 M<br>(54.0)     | 36.00 M              | 28.00 M<br>(27.00)   | 18.00 M              | 15.00 M<br>(14.40)  | 8.00 M<br>(7.85)    |                 |
|                 | 10000A             | 360.0 M<br>(334.5)    | 300.0 M               | 280.0 M<br>(250.9)    | 240.0 M               | 200.0 M               | 120.0 M              | 60.0 M               | 40.0 M               | 30.00 M              | 20.00 M              | 16.00 M             | 8.40 M<br>(8.73)    |                 |
|                 | 12000A             | 420 M<br>(401)        | 360.0 M               | 320.0 M<br>(301.1)    | 300.0 M<br>(288.0)    | 240.0 M               | 150.0 M<br>(144.0)   | 72.0 M               | 48.0 M               | 36.00 M              | 24.00 M              | 20.00 M<br>(19.20)  | 12.00 M<br>(10.47)  |                 |
|                 | 15000A             | 560 M<br>(502)        | 450 M                 | 400 M<br>(376)        | 360.0 M               | 300.0 M               | 180.0 M              | 90.0 M               | 60.0 M               | 45.0 M               | 30.00 M              | 24.00 M             | 14.00 M<br>(13.09)  |                 |
|                 | 20000A             | 720 M<br>(669)        | 600 M                 | 560 M<br>(502)        | 480 M                 | 400 M                 | 240.0 M              | 120.0 M              | 80.0 M               | 60.0 M               | 40.0 M               | 32.00 M             | 18.00 M<br>(17.45)  |                 |
|                 | 30000A             | 900 M                 | 750 M                 | 640 M<br>(502)        | 560 M                 | 480 M                 | 360.0 M              | 180.0 M              | 120.0 M              | 90.0 M               | 60.0 M               | 48.0 M              | 28.00 M<br>(26.18)  |                 |

<Note 1>

Parenthesis is primary active power (reactive power) value in /1kW(1kvar).

In the blank, setting is impossible.

About active power and reactive power range.

Full scale display, less than 4000 : 4 digit. More than 4000 : 3 digit.

An example) 4800kW → 4.80MW

40kvar → 40.0kvar

20kW → 20.00kW

<Note 2>

In case the voltage range and the current range were set as [ ] of an upper table and an output pulse unit (a four-step setup is possible) is set as the fastest. The output pulse width of a pulse output is set to 100 ~130ms. (Usually 240~260ms)

Appendix table 1-3

Active power range, watt-hour multiplier rate table (3-phase 3-wire)

| Multiplier rate | V range |                    | 600V               | 600V               | 500V               | 300V               | 150V       | Multiplier rate |
|-----------------|---------|--------------------|--------------------|--------------------|--------------------|--------------------|------------|-----------------|
|                 | A range |                    | (VT460/110V) [W]   | (VT440/110V) [W]   | (VT380/110V) [W]   | (VT220/110V) [W]   | (110V) [W] |                 |
| × 0.1           | 5A      |                    | 4.20 k<br>(4.18)   | 4.00 k             | 3600 k<br>(3455)   | 2000               | 1000       | × 0.01          |
|                 | 6A      |                    | 5.60 k<br>(5.02)   | 4.80 k             | 4.20 k<br>(4.15)   | 2400               | 1200       |                 |
|                 | 7.5A    |                    | 6.40 k<br>(6.27)   | 6.00 k             | 5.60 k<br>(5.18)   | 3000               | 1500       |                 |
|                 | 8A      |                    | 7.20 k<br>(6.69)   | 6.40 k             | 5.60 k<br>(5.53)   | 3200               | 1600       |                 |
|                 | 10A     |                    | 8.40 k<br>(8.36)   | 8.00 k             | 7.20 k<br>(6.91)   | 4.00 k             | 2000       |                 |
|                 | 12A     |                    | 10.00 k<br>(10.04) | 9.60 k             | 8.40 k<br>(8.29)   | 4.80 k             | 2400       |                 |
|                 | 15A     |                    | 14.00 k<br>(12.55) | 12.00 k            | 10.00 k<br>(10.36) | 6.00 k             | 3000       |                 |
|                 | 20A     |                    | 18.00 k<br>(16.73) | 16.00 k            | 14.00 k<br>(13.82) | 8.00 k             | 4.00 k     |                 |
|                 | 25A     |                    | 24.00 k<br>(20.91) | 20.00 k            | 18.00 k<br>(17.27) | 10.00 k            | 5.00 k     |                 |
|                 | 30A     |                    | 28.00 k<br>(25.09) | 24.00 k            | 20.00 k<br>(20.73) | 12.00 k            | 6.00 k     |                 |
|                 | 40A     |                    | 36.00 k<br>(33.45) | 32.00 k            | 28.00 k<br>(27.64) | 16.00 k            | 8.00 k     |                 |
|                 | × 0.1   | 50A                |                    | 42.0 k<br>(41.8)   | 40.0 k             | 36.00 k<br>(34.55) | 20.00 k    |                 |
| 60A             |         |                    | 56.0 k<br>(50.2)   | 48.0 k             | 42.0 k<br>(41.5)   | 24.00 k            | 12.00 k    |                 |
| 75A             |         |                    | 64.0 k<br>(62.7)   | 60.0 k             | 56.0 k<br>(51.8)   | 30.00 k            | 15.00 k    |                 |
| 80A             |         |                    | 72.0 k<br>(66.9)   | 64.0 k             | 56.0 k<br>(55.3)   | 32.00 k            | 16.00 k    |                 |
| 100A            |         |                    | 84.0 k<br>(83.6)   | 80.0 k             | 72.0 k<br>(69.1)   | 40.0 k             | 20.00 k    |                 |
| 120A            |         |                    | 100.0 k<br>(100.4) | 96.0 k             | 84.0 k<br>(82.9)   | 48.0 k             | 24.00 k    |                 |
| 150A            |         |                    | 140.0 k<br>(125.5) | 120.0 k            | 100.0 k<br>(103.6) | 60.0 k             | 30.00 k    |                 |
| 200A            |         |                    | 180.0 k<br>(167.3) | 160.0 k            | 140.0 k<br>(138.2) | 80.0 k             | 40.0 k     |                 |
| 250A            |         |                    | 240.0 k<br>(209.1) | 200.0 k            | 180.0 k<br>(172.7) | 100.0 k            | 50.0 k     |                 |
| 300A            |         |                    | 280.0 k<br>(250.9) | 240.0 k            | 200.0 k<br>(207.3) | 120.0 k            | 60.0 k     |                 |
| 400A            |         |                    | 360.0 k<br>(334.5) | 320.0 k            | 280.0 k<br>(276.4) | 160.0 k            | 80.0 k     |                 |
| 500A            |         |                    | 420 k<br>(418)     | 400 k              | 360.0 k<br>(345.5) | 200.0 k            | 100.0 k    | × 1             |
| 600A            |         | 560 k<br>(502)     | 480 k              | 420 k<br>(415)     | 240.0 k            | 120.0 k            |            |                 |
| 750A            |         | 640 k<br>(627)     | 600 k              | 560 k<br>(518)     | 300.0 k            | 150.0 k            |            |                 |
| 800A            |         | 720 k<br>(669)     | 640 k              | 560 k<br>(553)     | 320.0 k            | 160.0 k            |            |                 |
| 900A            |         | 800 k<br>(753)     | 720 k              | 640 k<br>(622)     | 360.0 k            | 180.0 k            |            |                 |
| 1000A           |         | 840 k<br>(836)     | 800 k              | 720 k<br>(691)     | 400 k              | 200.0 k            |            |                 |
| 1200A           |         | 1000 k<br>(1004)   | 960 k              | 840 k<br>(829)     | 480 k              | 240.0 k            |            |                 |
| 1500A           |         | 1400 k<br>(1255)   | 1200 k             | 1000 k<br>(1036)   | 600 k              | 300.0 k            |            |                 |
| 1600A           |         | 1400 k<br>(1338)   | 1400 k             | 1200 k<br>(1105)   | 640 k              | 320.0 k            |            |                 |
| 1800A           |         | 1600 k<br>(1505)   | 1500 k             | 1400 k<br>(1244)   | 720 k              | 360.0 k            |            |                 |
| 2000A           |         | 1800 k<br>(1673)   | 1600 k             | 1400 k<br>(1382)   | 800 k              | 400 k              |            |                 |
| 2500A           |         | 2400 k<br>(2091)   | 2000 k             | 1800 k<br>(1727)   | 1000 k             | 500 k              |            |                 |
| 3000A           |         | 2800 k<br>(2509)   | 2400 k             | 2000 k<br>(2073)   | 1200 k             | 600 k              | × 10       |                 |
| 4000A           |         | 3600 k<br>(3345)   | 3200 k             | 2800 k<br>(2764)   | 1600 k             | 800 k              |            |                 |
| 5000A           |         | 4.20 M<br>(4.18)   | 4.00 M             | 3600 k<br>(3455)   | 2000 k             | 1000 k             |            |                 |
| 6000A           |         | 5.60 M<br>(5.02)   | 4.80 M             | 4.20 M<br>(4.15)   | 2400 k             | 1200 k             |            |                 |
| 7500A           |         | 6.40 M<br>(6.27)   | 6.00 M             | 5.60 M<br>(5.18)   | 3000 k             | 1500 k             |            |                 |
| 8000A           |         | 7.20 M<br>(6.69)   | 6.40 M             | 5.60 M<br>(5.53)   | 3200 k             | 1600 k             |            |                 |
| 9000A           |         | 8.00 M<br>(7.53)   | 7.20 M             | 6.40 M<br>(6.22)   | 3600 k             | 1800 k             |            |                 |
| 10000A          |         | 8.40 M<br>(8.36)   | 8.00 M             | 7.20 M<br>(6.91)   | 4.00 M             | 2000 k             |            |                 |
| 12000A          |         | 10.00 M<br>(10.04) | 9.60 M             | 8.40 M<br>(8.29)   | 4.80 M             | 2400 k             |            |                 |
| 15000A          |         | 14.00 M<br>(12.55) | 12.00 M            | 10.00 M<br>(10.36) | 6.00 M             | 3000 k             |            |                 |
| 20000A          |         | 18.00 M<br>(16.73) | 16.00 M            | 14.00 M<br>(13.82) | 8.00 M             | 4.00 M             |            |                 |
| 30000A          |         | 28.00 M<br>(25.09) | 24.00 M            | 20.00 M<br>(20.73) | 12.00 M            | 6.00 M             |            | × 100           |
| 150000A         |         | 14.00 M<br>(12.55) | 12.00 M            | 10.00 M<br>(10.36) | 6.00 M             | 3000 k             |            |                 |
| 200000A         |         | 18.00 M<br>(16.73) | 16.00 M            | 14.00 M<br>(13.82) | 8.00 M             | 4.00 M             |            |                 |
| 300000A         |         | 28.00 M<br>(25.09) | 24.00 M            | 20.00 M<br>(20.73) | 12.00 M            | 6.00 M             | × 1000     |                 |
| 1500000A        |         | 14.00 M<br>(12.55) | 12.00 M            | 10.00 M<br>(10.36) | 6.00 M             | 3000 k             |            |                 |
| 2000000A        |         | 18.00 M<br>(16.73) | 16.00 M            | 14.00 M<br>(13.82) | 8.00 M             | 4.00 M             |            |                 |

<Note 1>

Parenthesis is primary active power (reactive power) value in /1kW(1kvar).

In the blank, setting is impossible.

About active power and reactive power range.

Full scale display, less than 4000 : 4 digit. More than 4000 : 3 digit.

An example) 4800kW → 4.80MW

40kvar → 40.0kvar

20kW → 20.00kW

<Note 2>

In case the voltage range and the current range were set as [ ] of an upper table and an output pulse unit (a four-step setup is possible) is set as the fastest. The output pulse width of a pulse output is set to 100 ~130ms. (Usually 240~260ms)

Appendix table 2

Active power range, watt-hour multiplier rate table (Single-phase 3-wire)

| V range<br>A range | 150V<br>(110V)<br>[W] | Multiplier<br>rate |
|--------------------|-----------------------|--------------------|
| 5A                 | 1000                  |                    |
| 6A                 | 1200                  |                    |
| 7.5A               | 1500                  |                    |
| 8A                 | 1600                  |                    |
| 10A                | 2000                  |                    |
| 12A                | 2400                  |                    |
| 15A                | 3000                  |                    |
| 20A                | 4.00 k                |                    |
| 25A                | 5.00 k                |                    |
| 30A                | 6.00 k                |                    |
| 40A                | 8.00 k                | ×0.1               |
| 50A                | 10.00 k               |                    |
| 60A                | 12.00 k               |                    |
| 75A                | 15.00 k               |                    |
| 80A                | 16.00 k               |                    |
| 100A               | 20.00 k               |                    |
| 120A               | 24.00 k               |                    |
| 150A               | 30.00 k               |                    |
| 200A               | 40.0 k                |                    |
| 250A               | 50.0 k                |                    |
| 300A               | 60.0 k                |                    |
| 400A               | 80.0 k                | ×1                 |
| 500A               | 100.0 k               |                    |
| 600A               | 120.0 k               |                    |
| 750A               | 150.0 k               |                    |
| 800A               | 160.0 k               |                    |
| 900A               | 180.0 k               |                    |
| 1000A              | 200.0 k               |                    |
| 1200A              | 240.0 k               |                    |
| 1500A              | 300.0 k               |                    |
| 1600A              | 320.0 k               |                    |
| 1800A              | 360.0 k               |                    |
| 2000A              | 400 k                 |                    |
| 2500A              | 500 k                 |                    |
| 3000A              | 600 k                 |                    |
| 4000A              | 800 k                 | ×10                |
| 5000A              | 1000 k                |                    |
| 6000A              | 1200 k                |                    |
| 7500A              | 1500 k                |                    |
| 8000A              | 1600 k                |                    |
| 9000A              | 1800 k                |                    |
| 10000A             | 2000 k                |                    |
| 12000A             | 2400 k                |                    |
| 15000A             | 3000 k                |                    |
| 20000A             | 4.00 M                |                    |
| 30000A             | 6.00 M                | ×100               |

<Note 1>

Parenthesis is primary active power (reactive power) value in /1kW(1kvar).  
 In the blank, setting is impossible.  
 About active power and reactive power range.  
 Full scale display, less than 4000 : 4 digit. More than 4000 : 3 digit.  
 An example) 4800kW → 4.80MW  
 40kvar → 40.0kvar  
 20kW → 20.00kW

<Note 2>

In case the voltage range and the current range were set as [ ] of an upper table and an output pulse unit (a four-step setup is possible) is set as the fastest. The output pulse width of a pulse output is set to 100 ~130ms. (Usually 240~260ms)

Appendix table 3-1

Active power range, watt-hour multiplier rate table (Single-phase 2-wire)

| Multiplier rate | V range<br>A range | 750.0kV                | 500.0kV                | 375.0kV                | 300.0kV                | 255.0kV                | 210.0kV                | 180.0kV                | 150.0kV                | 105.0kV               | 90.0kV                | 45.0kV                | 30.0kV                | Multiplier rate |
|-----------------|--------------------|------------------------|------------------------|------------------------|------------------------|------------------------|------------------------|------------------------|------------------------|-----------------------|-----------------------|-----------------------|-----------------------|-----------------|
|                 |                    | (VT550000/110V)<br>[W] | (VT380000/110V)<br>[W] | (VT275000/110V)<br>[W] | (VT220000/110V)<br>[W] | (VT187000/110V)<br>[W] | (VT154000/110V)<br>[W] | (VT132000/110V)<br>[W] | (VT110000/110V)<br>[W] | (VT77000/110V)<br>[W] | (VT66000/110V)<br>[W] | (VT33000/110V)<br>[W] | (VT22000/110V)<br>[W] |                 |
| × 100           | 5A                 | 2500 k                 | 1800 k<br>(1727)       | 1400 k<br>(1250)       | 1000 k                 | 900 k<br>(850)         | 720 k<br>(700)         | 600 k                  | 500 k                  | 360.0 k<br>(350.0)    | 300.0 k               | 150.0 k               | 100.0 k               |                 |
|                 | 6A                 | 3000 k                 | 2000 k<br>(2073)       | 1500 k                 | 1200 k                 | 1000 k<br>(1020)       | 840 k                  | 720 k                  | 600 k                  | 420 k                 | 360.0 k               | 180.0 k               | 120.0 k               |                 |
|                 | 7.5A               | 4.00 M<br>(3.75)       | 2800 k<br>(2591)       | 2000 k<br>(1875)       | 1500 k                 | 1400 k<br>(1275)       | 1200 k<br>(1050)       | 900 k                  | 750 k                  | 560 k<br>(525)        | 450 k                 | 240.0 k<br>(225.0)    | 150.0 k               |                 |
|                 | 8A                 | 4.00 M                 | 2800 k<br>(2764)       | 2000 k                 | 1600 k                 | 1400 k<br>(1360)       | 1200 k<br>(1120)       | 960 k                  | 800 k                  | 560 k                 | 480 k                 | 240.0 k               | 160.0 k               |                 |
|                 | 10A                | 5.00 M                 | 3600 k<br>(3455)       | 2500 k                 | 2000 k                 | 1800 k<br>(1700)       | 1400 k                 | 1200 k                 | 1000 k                 | 720 k<br>(700)        | 600 k                 | 300.0 k               | 200.0 k               |                 |
|                 | 12A                | 6.00 M                 | 4.20 M<br>(4.15)       | 3000 k                 | 2400 k                 | 2000 k<br>(2040)       | 1800 k<br>(1680)       | 1500 k<br>(1440)       | 1200 k                 | 840 k                 | 720 k                 | 360.0 k               | 240.0 k               |                 |
|                 | 15A                | 7.50 M                 | 5.60 M<br>(5.18)       | 4.00 M<br>(3.75)       | 3000 k                 | 2800 k<br>(2550)       | 2400 k<br>(2100)       | 1800 k                 | 1500 k                 | 1200 k<br>(1050)      | 900 k                 | 450 k                 | 300.0 k               |                 |
|                 | 20A                | 10.00 M                | 7.20 M<br>(6.91)       | 5.00 M                 | 4.00 M                 | 3600 k<br>(3400)       | 2800 k                 | 2400 k                 | 2000 k                 | 1400 k                | 1200 k                | 600 k                 | 400 k                 |                 |
|                 | 25A                | 14.00 M<br>(12.50)     | 9.00 M<br>(8.64)       | 6.40 M<br>(6.25)       | 5.00 M                 | 4.50 M<br>(4.25)       | 3600 k<br>(3500)       | 3000 k                 | 2500 k                 | 1800 k<br>(1750)      | 1500 k                | 750 k                 | 500 k                 |                 |
|                 | 30A                | 15.00 M                | 10.00 M<br>(10.36)     | 7.50 M                 | 6.00 M                 | 5.60 M<br>(5.10)       | 4.20 M                 | 3600 k                 | 3000 k                 | 2400 k<br>(2100)      | 1800 k                | 900 k                 | 600 k                 |                 |
|                 | 40A                | 20.00 M                | 14.00 M<br>(13.82)     | 10.00 M                | 8.00 M                 | 7.20 M<br>(6.80)       | 5.60 M                 | 4.80 M                 | 4.00 M                 | 2800 k                | 2400 k                | 1200 k                | 800 k                 | × 10            |
|                 | 50A                | 25.00 M                | 18.00 M<br>(17.27)     | 14.00 M<br>(12.50)     | 10.00 M                | 9.00 M<br>(8.50)       | 7.20 M<br>(7.00)       | 6.00 M                 | 5.00 M                 | 3600 k<br>(3500)      | 3000 k                | 1500 k                | 1000 k                |                 |
|                 | 60A                | 30.00 M                | 20.00 M<br>(20.73)     | 15.00 M                | 12.00 M                | 10.00 M<br>(10.20)     | 8.40 M                 | 7.20 M                 | 6.00 M                 | 4.20 M                | 3600 k                | 1800 k                | 1200 k                |                 |
|                 | 75A                | 40.0 M<br>(37.5)       | 28.00 M<br>(25.91)     | 20.00 M<br>(18.75)     | 15.00 M                | 14.00 M<br>(12.75)     | 12.00 M<br>(10.50)     | 9.00 M                 | 7.50 M                 | 5.60 M<br>(5.25)      | 4.50 M                | 2400 k<br>(2250)      | 1500 k                |                 |
|                 | 80A                | 40.0 M                 | 28.00 M<br>(27.64)     | 20.00 M                | 16.00 M                | 14.00 M<br>(13.60)     | 12.00 M<br>(11.20)     | 9.60 M                 | 8.00 M                 | 5.60 M                | 4.80 M                | 2400 k                | 1600 k                |                 |
| 100A            | 50.0 M             | 36.00 M<br>(34.55)     | 25.00 M                | 20.00 M                | 18.00 M<br>(17.00)     | 14.00 M                | 12.00 M                | 10.00 M                | 7.20 M<br>(7.00)       | 6.00 M                | 3000 k                | 2000 k                |                       |                 |
| 120A            | 60.0 M             | 42.0 M<br>(41.5)       | 30.00 M                | 24.00 M                | 20.00 M<br>(20.40)     | 18.00 M<br>(16.80)     | 15.00 M<br>(14.40)     | 12.00 M                | 8.40 M                 | 7.20 M                | 3600 k                | 2400 k                |                       |                 |
| 150A            | 75.0 M             | 56.0 M<br>(51.8)       | 40.0 M<br>(37.50)      | 30.00 M                | 28.00 M<br>(25.50)     | 24.00 M<br>(21.00)     | 18.00 M                | 15.00 M                | 12.00 M<br>(10.50)     | 9.00 M                | 4.50 M                | 3000 k                |                       |                 |
| 200A            | 100.0 M            | 72.0 M<br>(69.1)       | 50.0 M                 | 40.0 M                 | 36.00 M<br>(34.00)     | 28.00 M                | 24.00 M                | 20.00 M                | 14.00 M                | 12.00 M               | 6.00 M                | 4.00 M                |                       |                 |
| 250A            | 140.0 M<br>(125.0) | 90.0 M<br>(86.4)       | 64.0 M<br>(62.5)       | 50.0 M                 | 45.0 M<br>(42.5)       | 36.00 M<br>(35.00)     | 30.00 M                | 25.00 M                | 18.00 M<br>(17.50)     | 15.00 M               | 7.50 M                | 5.00 M                |                       |                 |
| 300A            | 150.0 M            | 100.0 M<br>(103.6)     | 75.0 M                 | 60.0 M                 | 56.0 M<br>(51.0)       | 42.0 M                 | 36.00 M                | 30.00 M                | 24.00 M<br>(21.00)     | 18.00 M               | 9.00 M                | 6.00 M                |                       |                 |
| 400A            | 200.0 M            | 140.0 M<br>(138.2)     | 100.0 M                | 80.0 M                 | 72.0 M<br>(68.0)       | 56.0 M                 | 48.0 M                 | 40.0 M                 | 28.00 M                | 24.00 M               | 12.00 M               | 8.00 M                | × 100                 |                 |
| 500A            | 250.0 M            | 180.0 M<br>(172.7)     | 140.0 M<br>(125.0)     | 100.0 M                | 90.0 M<br>(85.0)       | 72.0 M<br>(70.0)       | 60.0 M                 | 50.0 M                 | 36.00 M<br>(35.00)     | 30.00 M               | 15.00 M               | 10.00 M               |                       |                 |
| 600A            | 300.0 M            | 200.0 M<br>(207.3)     | 150.0 M                | 120.0 M                | 100.0 M<br>(102.0)     | 84.0 M                 | 72.0 M                 | 60.0 M                 | 42.0 M                 | 36.00 M               | 18.00 M               | 12.00 M               |                       |                 |
| 750A            | 400 M              | 280.0 M<br>(259.1)     | 200.0 M<br>(187.5)     | 150.0 M                | 140.0 M<br>(127.5)     | 120.0 M<br>(105.0)     | 90.0 M                 | 75.0 M                 | 56.0 M<br>(52.5)       | 45.0 M                | 24.00 M<br>(22.50)    | 15.00 M               |                       |                 |
| 800A            | 400 M              | 280.0 M<br>(276.4)     | 200.0 M                | 160.0 M                | 140.0 M<br>(136.0)     | 120.0 M<br>(112.0)     | 96.0 M                 | 80.0 M                 | 56.0 M                 | 48.0 M                | 24.00 M               | 16.00 M               |                       |                 |
| 900A            | 450 M              | 320.0 M<br>(310.9)     | 240.0 M<br>(225.0)     | 180.0 M                | 160.0 M<br>(153.0)     | 140.0 M<br>(126.0)     | 120.0 M<br>(108.0)     | 90.0 M                 | 64.0 M<br>(63.0)       | 56.0 M<br>(54.0)      | 28.00 M<br>(27.00)    | 18.00 M               |                       |                 |
| 1000A           | 500 M              | 360.0 M<br>(345.5)     | 250.0 M                | 200.0 M                | 180.0 M<br>(170.0)     | 140.0 M                | 120.0 M                | 100.0 M                | 72.0 M<br>(70.0)       | 60.0 M                | 30.00 M               | 20.00 M               |                       |                 |
| 1200A           | 600 M              | 420 M<br>(415)         | 300.0 M                | 240.0 M                | 200.0 M<br>(204.0)     | 180.0 M<br>(168.0)     | 150.0 M<br>(144.0)     | 120.0 M                | 84.0 M                 | 72.0 M                | 36.00 M               | 24.00 M               |                       |                 |
| 1500A           | 750 M              | 560 M<br>(518)         | 400 M<br>(375)         | 300.0 M                | 280.0 M<br>(255.0)     | 240.0 M<br>(210.0)     | 180.0 M                | 150.0 M                | 120.0 M<br>(105.0)     | 90.0 M                | 45.0 M                | 30.00 M               |                       |                 |
| 1600A           | 800 M              | 560 M<br>(553)         | 400 M                  | 320.0 M                | 280.0 M<br>(272.0)     | 240.0 M<br>(224.0)     | 200.0 M<br>(192.0)     | 160.0 M                | 120.0 M<br>(112.0)     | 96.0 M                | 48.0 M                | 32.00 M               |                       |                 |
| 1800A           | 900 M              | 640 M<br>(622)         | 450 M                  | 360.0 M                | 320.0 M<br>(306.0)     | 280.0 M<br>(252.0)     | 240.0 M<br>(216.0)     | 180.0 M                | 140.0 M<br>(126.0)     | 120.0 M<br>(108.0)    | 56.0 M<br>(54.0)      | 36.00 M               |                       |                 |
| 2000A           |                    | 720 M<br>(691)         | 500 M                  | 400 M                  | 360.0 M<br>(340.0)     | 280.0 M                | 240.0 M                | 200.0 M                | 140.0 M                | 120.0 M               | 60.0 M                | 40.0 M                |                       |                 |
| 2500A           |                    | 900 M<br>(864)         | 640 M<br>(625)         | 500 M                  | 450 M<br>(425)         | 360.0 M<br>(350.0)     | 300.0 M                | 250.0 M                | 180.0 M<br>(175.0)     | 150.0 M               | 75.0 M                | 50.0 M                |                       |                 |
| 3000A           |                    |                        | 750 M                  | 600 M                  | 560 M<br>(510)         | 420 M                  | 360.0 M                | 300.0 M                | 240.0 M<br>(210.0)     | 180.0 M               | 90.0 M                | 60.0 M                |                       |                 |
| 4000A           |                    |                        |                        | 800 M                  | 720 M<br>(680)         | 560 M                  | 480 M                  | 400 M                  | 280.0 M                | 240.0 M               | 120.0 M               | 80.0 M                | × 1000                |                 |
| 5000A           |                    |                        |                        |                        | 900 M<br>(850)         | 720 M<br>(700)         | 600 M                  | 500 M                  | 360.0 M<br>(350.0)     | 300.0 M               | 150.0 M               | 100.0 M               |                       |                 |
| 6000A           |                    |                        |                        |                        |                        | 840 M                  | 720 M                  | 600 M                  | 420 M                  | 360.0 M               | 180.0 M               | 120.0 M               |                       |                 |
| 7500A           |                    |                        |                        |                        |                        |                        | 900 M                  | 750 M                  | 560 M<br>(525)         | 450 M                 | 240.0 M<br>(225.0)    | 150.0 M               |                       |                 |
| 8000A           |                    |                        |                        |                        |                        |                        |                        | 800 M                  | 560 M                  | 480 M                 | 240.0 M               | 160.0 M               |                       |                 |
| 9000A           |                    |                        |                        |                        |                        |                        |                        |                        | 640 M<br>(630)         | 560 M<br>(540)        | 280.0 M<br>(270.0)    | 180.0 M               |                       |                 |
| 10000A          |                    |                        |                        |                        |                        |                        |                        |                        | 720 M<br>(700)         | 600 M                 | 300.0 M               | 200.0 M               |                       |                 |
| 12000A          |                    |                        |                        |                        |                        |                        |                        |                        | 840 M                  | 720 M                 | 360.0 M               | 240.0 M               |                       |                 |
| 15000A          |                    |                        |                        |                        |                        |                        |                        |                        |                        | 900 M                 | 450 M                 | 300.0 M               |                       |                 |
| 20000A          |                    |                        |                        |                        |                        |                        |                        |                        |                        |                       | 600 M                 | 400 M                 |                       |                 |
| 30000A          |                    |                        |                        |                        |                        |                        |                        |                        |                        |                       | 900 M                 | 600 M                 | × 10000               |                 |

<Note 1>

Parenthesis is primary active power (reactive power) value in /500W (500var).  
 In the blank, setting is impossible.  
 About active power and reactive power range.  
 Full scale display, less than 4000 : 4 digit. More than 4000 : 3 digit.  
 An example) 4800kW → 4.80MW  
 40kvar → 40.0kvar  
 20kW → 20.00kW

<Note 2>

In case the voltage range and the current range were set as [ ] of an upper table and an output pulse unit (a four-step setup is possible) is set as the fastest. The output pulse width of a pulse output is set to 100 ~130ms. (Usually 240~260ms)

Appendix table 3-2

Active power range, watt-hour multiplier rate table (Single-phase 2-wire)

| Multiplier rate | V range<br>A range | 25.00kV               | 24.00kV               | 18.00kV               | 18.00kV               | 15.00kV               | 9000V                | 4500V                | 3000V                | 2400V                | 1500V                | 1200V               | 600V                | Multiplier rate |
|-----------------|--------------------|-----------------------|-----------------------|-----------------------|-----------------------|-----------------------|----------------------|----------------------|----------------------|----------------------|----------------------|---------------------|---------------------|-----------------|
|                 |                    | (VT18400/110V)<br>[W] | (VT16500/110V)<br>[W] | (VT13800/110V)<br>[W] | (VT13200/110V)<br>[W] | (VT11000/110V)<br>[W] | (VT6600/110V)<br>[W] | (VT3300/110V)<br>[W] | (VT2200/110V)<br>[W] | (VT1650/110V)<br>[W] | (VT1100/110V)<br>[W] | (VT880/110V)<br>[W] | (VT480/110V)<br>[W] |                 |
| × 1             | 5A                 | 84.0 k<br>(83.6)      | 75.0 k                | 64.0 k<br>(62.7)      | 60.0 k                | 50.0 k                | 30.0 k               | 15.0 k               | 10.0 k               | 7.50 k               | 5.00 k               | 4.00 k              | 2400<br>(2182)      | × 0.1           |
|                 | 6A                 | 100.0 k<br>(100.4)    | 90.0 k                | 80.0 k<br>(75.3)      | 72.0 k                | 60.0 k                | 36.0 k               | 18.0 k               | 12.0 k               | 9.00 k               | 6.00 k               | 4.80 k              | 2800<br>(2618)      |                 |
|                 | 7.5A               | 140.0 k<br>(125.5)    | 120.0 k               | 96.0 k<br>(94.1)      | 90.0 k                | 75.0 k                | 45.0 k               | 24.0 k<br>(22.50)    | 15.0 k               | 12.00 k<br>(11.25)   | 7.50 k               | 6.00 k              | 3600<br>(3273)      |                 |
|                 | 8A                 | 140.0 k<br>(133.8)    | 120.0 k               | 100.0 k<br>(100.4)    | 96.0 k                | 80.0 k                | 48.0 k               | 24.0 k               | 16.0 k               | 12.00 k              | 8.00 k               | 6.40 k              | 3600<br>(3491)      |                 |
|                 | 10A                | 180.0 k<br>(167.3)    | 150.0 k               | 140.0 k<br>(125.5)    | 120.0 k               | 100.0 k               | 60.0 k               | 30.0 k               | 20.0 k               | 15.00 k              | 10.00 k              | 8.00 k              | 4.50 k<br>(4.36)    |                 |
|                 | 12A                | 200.0 k<br>(200.7)    | 180.0 k               | 160.0 k<br>(150.5)    | 150.0 k<br>(144.0)    | 120.0 k               | 72.0 k               | 36.0 k               | 24.0 k               | 18.00 k              | 12.00 k              | 9.60 k              | 5.60 k<br>(5.24)    |                 |
|                 | 15A                | 280.0 k<br>(250.9)    | 240.0 k<br>(225.0)    | 200.0 k<br>(188.2)    | 180.0 k               | 150.0 k               | 90.0 k               | 45.0 k               | 30.0 k               | 24.00 k<br>(22.50)   | 15.00 k              | 12.00 k             | 7.20 k<br>(6.55)    |                 |
|                 | 20A                | 360.0 k<br>(334.5)    | 300.0 k               | 280.0 k<br>(250.9)    | 240.0 k               | 200.0 k               | 120.0 k              | 60.0 k               | 40.0 k               | 30.00 k              | 20.00 k              | 16.00 k             | 9.00 k<br>(8.73)    |                 |
|                 | 25A                | 420 k<br>(418)        | 400 k<br>(375.0)      | 320.0 k<br>(313.6)    | 300.0 k               | 250.0 k               | 150.0 k              | 75.0 k               | 50.0 k               | 40.0 k<br>(37.5)     | 25.00 k              | 20.00 k             | 12.00 k<br>(10.91)  |                 |
|                 | 30A                | 560 k<br>(502)        | 450 k                 | 400 k<br>(376.4)      | 360.0 k               | 300.0 k               | 180.0 k              | 90.0 k               | 60.0 k               | 45.0 k               | 30.00 k              | 24.00 k             | 14.00 k<br>(13.09)  |                 |
| × 10            | 40A                | 720 k<br>(669)        | 600 k                 | 560 k<br>(502)        | 480 k                 | 400 k                 | 240.0 k              | 120.0 k              | 80.0 k               | 60.0 k               | 40.0 k               | 32.00 k             | 18.00 k<br>(17.45)  | × 1             |
|                 | 50A                | 840 k<br>(836)        | 750 k                 | 640 k<br>(627)        | 600 k                 | 500 k                 | 300.0 k              | 150.0 k              | 100.0 k              | 75.0 k               | 50.0 k               | 40.0 k              | 24.00 k<br>(21.82)  |                 |
|                 | 60A                | 1000 k<br>(1004)      | 900 k                 | 800 k<br>(753)        | 720 k                 | 600 k                 | 360.0 k              | 180.0 k              | 120.0 k              | 90.0 k               | 60.0 k               | 48.0 k              | 28.00 k<br>(26.18)  |                 |
|                 | 75A                | 1400 k<br>(1255)      | 1200 k<br>(1125)      | 960 k<br>(941)        | 900 k                 | 750 k                 | 450 k                | 240.0 k<br>(225.0)   | 150.0 k              | 120.0 k<br>(112.5)   | 75.0 k               | 60.0 k              | 36.00 k<br>(32.73)  |                 |
|                 | 80A                | 1400 k<br>(1338)      | 1200 k                | 1000 k<br>(1004)      | 960 k                 | 800 k                 | 480 k                | 240.0 k              | 160.0 k              | 120.0 k              | 80.0 k               | 64.0 k              | 36.00 k<br>(34.91)  |                 |
|                 | 100A               | 1800 k<br>(1673)      | 1500 k                | 1400 k<br>(1255)      | 1200 k                | 1000 k                | 600 k                | 300.0 k              | 200.0 k              | 150.0 k              | 100.0 k              | 80.0 k              | 45.0 k<br>(43.6)    |                 |
|                 | 120A               | 2000 k<br>(2007)      | 1800 k                | 1600 k<br>(1505)      | 1500 k<br>(1440)      | 1200 k                | 720 k                | 360.0 k              | 240.0 k              | 180.0 k              | 120.0 k              | 96.0 k              | 56.0 k<br>(52.4)    |                 |
|                 | 150A               | 2800 k<br>(2509)      | 2400 k<br>(2250)      | 2000 k<br>(1882)      | 1800 k                | 1500 k                | 900 k                | 450 k                | 300.0 k              | 240.0 k<br>(225.0)   | 150.0 k              | 120.0 k             | 72.0 k<br>(65.5)    |                 |
|                 | 200A               | 3600 k<br>(3345)      | 3000 k                | 2800 k<br>(2509)      | 2400 k                | 2000 k                | 1200 k               | 600 k                | 400 k                | 300.0 k              | 200.0 k              | 160.0 k             | 9.00 k<br>(87.3)    |                 |
|                 | 250A               | 4.20 M<br>(4.18)      | 4.00 M<br>(3.75)      | 3200 k<br>(3136)      | 3000 k                | 2500 k                | 1500 k               | 750 k                | 500 k                | 400 k<br>(375.0)     | 250.0 k              | 200.0 k             | 120.0 k<br>(109.1)  |                 |
| × 100           | 300A               | 5.60 M<br>(5.02)      | 4.50 M                | 4.00 M<br>(3.76)      | 3600 k                | 3000 k                | 1800 k               | 900 k                | 600 k                | 450 k                | 300.0 k              | 240.0 k             | 140.0 k<br>(130.9)  | × 10            |
|                 | 400A               | 7.20 M<br>(6.69)      | 6.00 M                | 5.60 M<br>(5.02)      | 4.80 M                | 4.00 M                | 2400 k               | 1200 k               | 800 k                | 600 k                | 400 k                | 320.0 k             | 180.0 k<br>(174.5)  |                 |
|                 | 500A               | 8.40 M<br>(8.36)      | 7.50 M                | 6.40 M<br>(6.27)      | 6.00 M                | 5.00 M                | 3000 k               | 1500 k               | 1000 k               | 750 k                | 500 k                | 400 k               | 240.0 k<br>(218.2)  |                 |
|                 | 600A               | 10.00 M<br>(10.04)    | 9.00 M                | 8.00 M<br>(7.53)      | 7.20 M                | 6.00 M                | 3600 k               | 1800 k               | 1200 k               | 900 k                | 600 k                | 480 k               | 280.0 k<br>(261.8)  |                 |
|                 | 750A               | 14.00 M<br>(12.55)    | 12.00 M<br>(11.25)    | 9.60 M<br>(9.41)      | 9.00 M                | 7.50 M                | 4.50 M               | 2400 k<br>(2250)     | 1500 k               | 1200 k<br>(1125)     | 750 k                | 600 k               | 360.0 k<br>(327.3)  |                 |
|                 | 800A               | 14.00 M<br>(13.38)    | 12.00 M               | 10.00 M<br>(10.04)    | 9.60 M                | 8.00 M                | 4.80 M               | 2400 k               | 1600 k               | 1200 k               | 800 k                | 640 k               | 360.0 k<br>(349.1)  |                 |
|                 | 900A               | 16.00 M<br>(15.05)    | 14.00 M<br>(13.50)    | 12.00 M<br>(11.29)    | 12.00 M<br>(10.80)    | 9.00 M                | 5.60 M<br>(5.40)     | 2800 k<br>(2700)     | 1800 k               | 1400 k<br>(1350)     | 900 k                | 720 k               | 400 k<br>(393)      |                 |
|                 | 1000A              | 18.00 M<br>(16.73)    | 15.00 M               | 14.00 M<br>(12.55)    | 12.00 M               | 10.00 M               | 6.00 M               | 3000 k               | 2000 k               | 1500 k               | 1000 k               | 800 k               | 450 k<br>(436)      |                 |
|                 | 1200A              | 20.00 M<br>(20.07)    | 18.00 M               | 16.00 M<br>(15.05)    | 15.00 M<br>(14.40)    | 12.00 M               | 7.20 M               | 3600 k               | 2400 k               | 1800 k               | 1200 k               | 960 k               | 560 k<br>(524)      |                 |
|                 | 1500A              | 28.00 M<br>(25.09)    | 24.00 M<br>(22.50)    | 20.00 M<br>(18.82)    | 18.00 M               | 15.00 M               | 9.00 M               | 4.50 M               | 3000 k               | 2400 k<br>(2250)     | 1500 k               | 1200 k              | 720 k<br>(655)      |                 |
| × 1000          | 1600A              | 28.00 M<br>(26.76)    | 24.00 M               | 24.00 M<br>(20.07)    | 20.00 M<br>(19.20)    | 16.00 M               | 9.60 M               | 4.80 M               | 3200 k               | 2400 k               | 1600 k               | 1400 k<br>(1280)    | 720 k<br>(698)      | × 10            |
|                 | 1800A              | 32.00 M<br>(30.11)    | 28.00 M<br>(27.00)    | 24.00 M<br>(22.58)    | 24.00 M<br>(21.60)    | 18.00 M               | 12.00 M<br>(10.80)   | 5.60 M<br>(5.40)     | 3600 k               | 2800 k<br>(2700)     | 1800 k               | 1500 k<br>(1440)    | 800 k<br>(785)      |                 |
|                 | 2000A              | 36.00 M<br>(33.45)    | 30.00 M               | 28.00 M<br>(25.09)    | 24.00 M               | 20.00 M               | 12.00 M              | 6.00 M               | 4.00 M               | 3000 k               | 2000 k               | 1600 k              | 900 k<br>(873)      |                 |
|                 | 2500A              | 42.0 M<br>(41.8)      | 40.0 M<br>(37.5)      | 32.00 M<br>(31.36)    | 30.00 M               | 25.00 M               | 15.00 M              | 7.50 M               | 5.00 M               | 4.00 M<br>(3.75)     | 2500 k               | 2000 k              | 1200 k<br>(1091)    |                 |
|                 | 3000A              | 56.0 M<br>(50.2)      | 45.0 M                | 40.0 M<br>(37.64)     | 36.00 M               | 30.00 M               | 18.00 M              | 9.00 M               | 6.00 M               | 4.50 M               | 3000 k               | 2400 k              | 1400 k<br>(1309)    |                 |
|                 | 4000A              | 72.0 M<br>(66.9)      | 60.0 M                | 56.0 M<br>(50.2)      | 48.0 M                | 40.0 M                | 24.00 M              | 12.00 M              | 8.00 M               | 6.00 M               | 4.00 M               | 3200 k              | 1800 k<br>(1745)    |                 |
|                 | 5000A              | 84.0 M<br>(83.6)      | 75.0 M                | 64.0 M<br>(62.7)      | 60.0 M                | 50.0 M                | 30.00 M              | 15.00 M              | 10.00 M              | 7.50 M               | 5.00 M               | 4.00 M              | 2400 k<br>(2182)    |                 |
|                 | 6000A              | 100.0 M<br>(100.4)    | 90.0 M                | 80.0 M<br>(75.3)      | 72.0 M                | 60.0 M                | 36.00 M              | 18.00 M              | 12.00 M              | 9.00 M               | 6.00 M               | 4.80 M              | 2800 k<br>(2618)    |                 |
|                 | 7500A              | 140.0 M<br>(125.5)    | 120.0 M               | 96.0 M<br>(94.1)      | 90.0 M                | 75.0 M                | 45.0 M               | 24.00 M<br>(22.50)   | 15.00 M              | 12.00 M<br>(11.25)   | 7.50 M               | 6.00 M              | 3600 k<br>(3273)    |                 |
|                 | 8000A              | 140.0 M<br>(133.8)    | 120.0 M               | 100.0 M<br>(100.4)    | 96.0 M                | 80.0 M                | 48.0 M               | 24.00 M              | 16.00 M              | 12.00 M              | 8.00 M               | 6.40 M              | 3600 k<br>(3491)    |                 |
| × 10000         | 9000A              | 160.0 M<br>(150.5)    | 140.0 M<br>(135.0)    | 120.0 M<br>(112.9)    | 120.0 M<br>(108.0)    | 90.0 M                | 56.0 M<br>(54.0)     | 28.00 M<br>(27.00)   | 18.00 M              | 14.00 M<br>(13.50)   | 9.00 M               | 7.20 M              | 4.00 M<br>(3.93)    | × 100           |
|                 | 10000A             | 180.0 M<br>(167.3)    | 150.0 M               | 140.0 M<br>(125.5)    | 120.0 M               | 100.0 M               | 60.0 M               | 30.00 M              | 20.00 M              | 15.00 M              | 10.00 M              | 8.00 M              | 4.50 M<br>(4.36)    |                 |
|                 | 12000A             | 200.0 M<br>(200.7)    | 180.0 M               | 160.0 M<br>(150.5)    | 150.0 M<br>(144.0)    | 120.0 M               | 72.0 M               | 36.00 M              | 24.00 M              | 18.00 M              | 12.00 M              | 9.60 M              | 5.60 M<br>(5.24)    |                 |
|                 | 15000A             | 280.0 M<br>(250.9)    | 240.0 M<br>(225.0)    | 200.0 M<br>(188.2)    | 180.0 M               | 150.0 M               | 90.0 M               | 45.0 M               | 30.00 M              | 24.00 M<br>(22.50)   | 15.00 M              | 12.00 M             | 7.20 M<br>(6.55)    |                 |
|                 | 20000A             | 360.0 M<br>(334.5)    | 300.0 M               | 280.0 M<br>(250.9)    | 240.0 M               | 200.0 M               | 120.0 M              | 60.0 M               | 40.0 M               | 30.00 M              | 20.00 M              | 16.00 M             | 9.00 M<br>(8.73)    |                 |
|                 | 30000A             | 560 M<br>(502)        | 450 M                 | 400 M<br>(376)        | 360.0 M               | 300.0 M               | 180.0 M              | 90.0 M               | 60.0 M               | 45.0 M               | 30.00 M              | 24.00 M             | 14.00 M<br>(13.09)  |                 |

<Note 1>

Parenthesis is primary active power (reactive power) value in /500W (500var).  
 In the blank, setting is impossible.  
 About active power and reactive power range.  
 Full scale display, less than 4000 : 4 digit. More than 4000 : 3 digit.  
 An example) 4800kW → 4.80MW  
 40kvar → 40.0kvar  
 20kW → 20.00kW

<Note 2>

In case the voltage range and the current range were set as [ ] of an upper table and an output pulse unit (a four-step setup is possible) is set as the fastest. The output pulse width of a pulse output is set to 100 ~130ms. (Usually 240~260ms)

Appendix table 3-3

Active power range, watt-hour multiplier rate table (Single-phase 2-wire)

| Multiplier rate | V range<br>A range | 600V                | 600V                | 500V                | 300V                | 150V          | Multiplier rate |
|-----------------|--------------------|---------------------|---------------------|---------------------|---------------------|---------------|-----------------|
|                 |                    | (VT460/110V)<br>[W] | (VT440/110V)<br>[W] | (VT380/110V)<br>[W] | (VT220/110V)<br>[W] | (110V)<br>[W] |                 |
| x 0.1           | 5A                 | 2400<br>(2091)      | 2000                | 1800<br>(1727)      | 1000                | 500           | x 0.01          |
|                 | 6A                 | 2800<br>(2509)      | 2400                | 2000<br>(2073)      | 1200                | 600           |                 |
|                 | 7.5A               | 3200<br>(3136)      | 3000                | 2800<br>(2591)      | 1500                | 750           |                 |
|                 | 8A                 | 3600<br>(3345)      | 3200                | 2800<br>(2764)      | 1600                | 800           |                 |
|                 | 10A                | 4.20 k<br>(4.18)    | 4.00 k              | 3600<br>(3455)      | 2000                | 1000          |                 |
|                 | 12A                | 5.60 k<br>(5.02)    | 4.80 k              | 4.20 k<br>(4.15)    | 2400                | 1200          |                 |
|                 | 15A                | 6.40 k<br>(6.27)    | 6.00 k              | 5.60 k<br>(5.18)    | 3000                | 1500          |                 |
|                 | 20A                | 8.40 k<br>(8.36)    | 8.00 k              | 7.20 k<br>(6.91)    | 4.00 k              | 2000          |                 |
|                 | 25A                | 12.00 k<br>(10.45)  | 10.00 k             | 9.00 k<br>(8.64)    | 5.00 k              | 2500          |                 |
|                 | 30A                | 14.00 k<br>(12.55)  | 12.00 k             | 10.00 k<br>(10.36)  | 6.00 k              | 3000          |                 |
| x 0.1           | 40A                | 18.00 k<br>(16.73)  | 16.00 k             | 14.00 k<br>(13.82)  | 8.00 k              | 4.00 k        | x 0.1           |
|                 | 50A                | 24.00 k<br>(20.91)  | 20.00 k             | 18.00 k<br>(17.27)  | 10.00 k             | 5.00 k        |                 |
|                 | 60A                | 28.00 k<br>(25.09)  | 24.00 k             | 20.00 k<br>(20.73)  | 12.00 k             | 6.00 k        |                 |
|                 | 75A                | 32.00 k<br>(31.36)  | 30.00 k             | 28.00 k<br>(25.91)  | 15.00 k             | 7.50 k        |                 |
|                 | 80A                | 36.00 k<br>(33.45)  | 32.00 k             | 28.00 k<br>(27.64)  | 16.00 k             | 8.00 k        |                 |
|                 | 100A               | 42.0 k<br>(41.8)    | 40.0 k              | 36.00 k<br>(34.55)  | 20.00 k             | 10.00 k       |                 |
|                 | 120A               | 56.0 k<br>(50.2)    | 48.0 k              | 42.0 k<br>(41.5)    | 24.00 k             | 12.00 k       |                 |
|                 | 150A               | 64.0 k<br>(62.7)    | 60.0 k              | 56.0 k<br>(51.8)    | 30.00 k             | 15.00 k       |                 |
|                 | 200A               | 84.0 k<br>(83.6)    | 80.0 k              | 72.0 k<br>(69.1)    | 40.0 k              | 20.00 k       |                 |
|                 | 250A               | 120.0 k<br>(104.5)  | 100.0 k             | 90.0 k<br>(86.4)    | 50.0 k              | 25.00 k       |                 |
| x 1             | 300A               | 140.0 k<br>(125.5)  | 120.0 k             | 100.0 k<br>(103.6)  | 60.0 k              | 30.00 k       | x 1             |
|                 | 400A               | 180.0 k<br>(167.3)  | 160.0 k             | 140.0 k<br>(138.2)  | 80.0 k              | 40.0 k        |                 |
|                 | 500A               | 240.0 k<br>(209.1)  | 200.0 k             | 180.0 k<br>(172.7)  | 100.0 k             | 50.0 k        |                 |
|                 | 600A               | 280.0 k<br>(250.9)  | 240.0 k             | 200.0 k<br>(207.3)  | 120.0 k             | 60.0 k        |                 |
|                 | 750A               | 320.0 k<br>(313.6)  | 300.0 k             | 280.0 k<br>(259.1)  | 150.0 k             | 75.0 k        |                 |
|                 | 800A               | 360.0 k<br>(334.5)  | 320.0 k             | 280.0 k<br>(276.4)  | 160.0 k             | 80.0 k        |                 |
|                 | 900A               | 400 k<br>(376.4)    | 360.0 k             | 320.0 k<br>(310.9)  | 180.0 k             | 90.0 k        |                 |
|                 | 1000A              | 420 k<br>(418)      | 400 k               | 360.0 k<br>(345.5)  | 200.0 k             | 100.0 k       |                 |
|                 | 1200A              | 560 k<br>(502)      | 480 k               | 420 k<br>(415)      | 240.0 k             | 120.0 k       |                 |
|                 | 1500A              | 640 k<br>(627)      | 600 k               | 560 k<br>(518)      | 300.0 k             | 150.0 k       |                 |
| x 10            | 1600A              | 720 k<br>(669)      | 640 k               | 560 k<br>(553)      | 320.0 k             | 160.0 k       | x 10            |
|                 | 1800A              | 800 k<br>(753)      | 720 k               | 640 k<br>(622)      | 360.0 k             | 180.0 k       |                 |
|                 | 2000A              | 840 k<br>(836)      | 800 k               | 720 k<br>(691)      | 400 k               | 200.0 k       |                 |
|                 | 2500A              | 1200 k<br>(1045)    | 1000 k              | 900 k<br>(864)      | 500 k               | 250.0 k       |                 |
|                 | 3000A              | 1400 k<br>(1255)    | 1200 k              | 1000 k<br>(1036)    | 600 k               | 300.0 k       |                 |
|                 | 4000A              | 1800 k<br>(1673)    | 1600 k              | 1400 k<br>(1382)    | 800 k               | 400 k         |                 |
|                 | 5000A              | 2400 k<br>(2091)    | 2000 k              | 1800 k<br>(1727)    | 1000 k              | 500 k         |                 |
|                 | 6000A              | 2800 k<br>(2509)    | 2400 k              | 2000 k<br>(2073)    | 1200 k              | 600 k         |                 |
|                 | 7500A              | 3200 k<br>(3136)    | 3000 k              | 2800 k<br>(2591)    | 1500 k              | 750 k         |                 |
|                 | 8000A              | 3600 k<br>(3345)    | 3200 k              | 2800 k<br>(2764)    | 1600 k              | 800 k         |                 |
| x 100           | 9000A              | 4.00 M<br>(3764)    | 3600 k              | 3200 k<br>(3109)    | 1800 k              | 900 k         | x 100           |
|                 | 10000A             | 4.20 M<br>(4.18)    | 4.00 M              | 3600 k<br>(3455)    | 2000 k              | 1000 k        |                 |
|                 | 12000A             | 5.60 M<br>(5.02)    | 4.80 M              | 4.20 M<br>(4.15)    | 2400 k              | 1200 k        |                 |
|                 | 15000A             | 6.40 M<br>(6.27)    | 6.00 M              | 5.60 M<br>(5.18)    | 3000 k              | 1500 k        |                 |
|                 | 20000A             | 8.40 M<br>(8.36)    | 8.00 M              | 7.20 M<br>(6.91)    | 4.00 M              | 2000 k        |                 |
|                 | 30000A             | 14.00 M<br>(12.55)  | 12.00 M             | 10.00 M<br>(10.36)  | 6.00 M              | 3000 k        |                 |

<Note 1>

Parenthesis is primary active power (reactive power) value in /500W(500var).  
 In the blank, setting is impossible.  
 About active power and reactive power range.  
 Full scale display, less than 4000 : 4 digit. More than 4000 : 3 digit.  
 An example) 4800kW → 4.80MW  
 40kvar → 40.0kvar  
 20kW → 20.00kW

<Note 2>

In case the voltage range and the current range were set as [ ] of an upper table and an output pulse unit (a four-step setup is possible) is set as the fastest. The output pulse width of a pulse output is set to 100 ~130ms. (Usually 240~260ms)

** DAIICHI ELECTRONICS CO., LTD.**

Tokyo Office : 11-13, Hitotsuya 1-chome, Adachi-ku, Tokyo, 121-8639, JAPAN.  
TEL : +81-3-3885-2411 , Fax : +81-3-3858-3966

Kyoto Office : 1-19, Ichinobe-Nishikawahara, Jyoyou-shi, Kyoto, 610-0114, JAPAN.  
TEL : +81-774-55-1391 , Fax : +81-774-54-1353

Revision D, DATE : November 6, 2015