

INSTRUCTION MANUAL

MAXIMUM (MINIMUM) SUPER MULTI-METER

SMLC-110L

Hardware Model D

Thank you for purchase of DAIICHI ELECTRONICS product.
Please read this instruction manual carefully before use.

Safety precautions

■ Usage environment and product conditions

Please be sure to use this product in a place that meets the following conditions.
In places that do not meet this condition, it may cause malfunction or failure and product life decline.

- Within the range of ambient temperature -10 to +55 °C, humidity 85% RH or less.
- Place free of dust, corrosive gas, salt and oily smoke. (Corrosive gas : SO₂ / H₂S, etc.)
- Location that is not affected by vibration and shock.
- Location that is not affected by external noise.
- Altitude 1000m or less.
- If this unit directly measures an inverter output of cycle control, SCR phase angle control or PWM control, an error may increase due to its operation principle.

■ Outdoor use conditions

- These products are not a dustproof, waterproof, and splash proof construction.
Please avoid the place with much dust. Moreover, please install in the place not exposed to rain nor water drop.
- Please do not install in the place where sunlight hits directly.
Discoloration and degradation of a name plate, and deformation of the case by the surface temperature rise may occur.

■ Mounting and wiring

Please refer to this instruction manual for mounting and the wiring.

 CAUTION	<ul style="list-style-type: none"> ● Please refer to connection diagram for the wiring. ● Please avoid a hot line work. ● Please use an electrical wire size suitable with the rated current. ● Please check the tightening of the screw.
---	---

■ Preparation

This product must be set before use. Please set correctly after reading this instruction manual.

■ About dew condensation

If the temperature and humidity of an installation change rapidly when a product is a non-energization, the waterdrop by dew condensation may adhere to a display inner side. (The display filter and the LCD surface stick and the pattern of the shape of a circle or an ellipse occur.)

This phenomenon does not cause any trouble. Disappears when control power is applied for 2 hours.

■ Maintenance and inspection

- Inspection in energized state is dangerous.
- No replacement in periodic inspection.
- After wiring change and maintenance, attach the terminal cover.
- Please wipe off lightly with the dry soft cloth. Please do not use the organic solvent, chemicals, cleaners, etc., such as an alcohol, for cleaning.

The LCD may light up during cleaning on the LCD screen. This is a phenomenon that static electricity occurs in the filter. There is no problem with the product. Leave the unit as it is for a while, and the display goes out due to natural discharge.

Do not press the LCD screen strongly. Pressing the LCD screen may cause the filter and the liquid crystal surface to remain in contact (such as a round pattern).

■ Storage

Please store in a place that meets the following conditions.

- The ambient temperature is within -25 to +70 °C (storage temperature).
- Daily average temperature 40 °C or less.
- Location corresponding to the usage environment and use conditions.
- Aluminum electrolytic capacitors are used for products. Please energize the power supply within one year after purchase.

■ Countermeasures against troubles.

If this product breaks down within the warranty period, it will be repaired by DAIICHI ELECTRONICS.

■ Disposal

Please dispose this product as industrial waste (non-combustible).
Mercury parts and a nickel-cadmium battery are not used for this product.

■ Warranty period.

The warranty period of the product is one year after the date of delivery.

■ Operation

Be careful with the following cautions during use.

- Use the input within the rated range. Be careful since negligence of this caution may cause troubles of the unit.
- There is a function to hold the maximum value and the minimum value with a measurement factor in this product. The blackout this value will not be cleared by a power supply reset. However, the minimum value may be updated in case input is not applied to a power up. Therefore the maximum value and the minimum value need to be reset of DI after a startup, or switch operation.

For this reason, in order to recover previous minimum value, please apply input within 1 second after switching on a power supply.

- The maximum value, a minimum value measurement factor

Measurement factor	Maximum value measurement	Minimum value measurement
3-phase voltage, Zero-phase voltage, Frequency	○	○

	<ul style="list-style-type: none"> ● Be careful not to touch any terminal when power is applied to the unit. ● Don't disassemble or modify this unit without any previous permission of our company, otherwise the warranty does not apply to the unit any more. Also, modifications may cause troubles, a fire, or other accidents. For specifications change, etc., please contact us.
---	--

■ Setting

This unit requires setting and confirmation of the measuring range, etc. before use.

Wrong setting, if any, causes malfunction of the unit. If setting should be wrong, neither measurement nor output becomes correct. Carefully read the instruction manual before setting the unit.

■ Default settings

The case of shipment of this product, it is the following default setting. Please set according to a use condition.

No.	Setting item	Phase voltage input		Line voltage input		
		Vo 190V	Vo 110V	Vo 190V	Vo 110V	
1	Display combination	Pattern	Pattern 1		Pattern 1	
		Main monitor	Maximum zero-phase voltage		Maximum zero-phase voltage	
		Sub-monitor (Left)	V(RS)		V(RS)	
		Sub-monitor (Center)	V(ST)		V(ST)	
		Sub-monitor (Right)	V(TR)		V(TR)	
	Bar graph	Maximum zero-phase voltage + Zero-phase voltage		Maximum zero-phase voltage + Zero-phase voltage		
2	Alarm output setting (1)	Alarm 1 factor	Zero-phase voltage		Zero-phase voltage	
		Alarm 1 reset form	AUTO <自動復帰>		AUTO <自動復帰>	
		Alarm 1 test <テスト>	—		—	
		Alarm 2 factor	OFF		OFF	
		Alarm 2 reset form	AUTO <自動復帰>		AUTO <自動復帰>	
	Alarm 2 test <テスト>	—		—		
3	3-phase voltage detection setting	Voltage upper limit	OFF		OFF	
		Voltage lower limit	OFF		OFF	
		Demand time interval	0 second <秒>		0 second <秒>	
4	Zero-phase voltage detection setting	Zero-phase voltage upper limit	5280V (/152V)	5280V (/88V)	5280V (/152V)	5280V (/88V)
		Response time	0.1 seconds <秒>		0.1 seconds <秒>	
		Ground fault phase detection display automatic change	OFF		OFF	
5	Backlight	Action	AUTO		AUTO	
		Brightness	3 (Middle)		3 (Middle)	
6	Measurement range	Voltage range	9000V (6600V/110V)		9000V (6600V/110V)	
		Zero-phase voltage scale	×1/√3 non display		×1/√3 non display	
		Frequency range	45.0 to 65.0Hz		45.0 to 65.0Hz	

No.	Setting item		Phase voltage input		Line voltage input		
			Vo 190V	Vo 110V	Vo 190V	Vo 110V	
7	Analog output (¹)	Output factor 1	Maximum zero-phase voltage		Maximum zero-phase voltage		
		Output factor 2	V(RS)		V(RS)		
		Output factor 3	V(ST)		V(ST)		
		Output factor 4	V(TR)		V(TR)		
		Low input cut	OFF		OFF		
8	External operation input (¹)(²)	Input 1 function	Alarm reset		Alarm reset		
		Input 2 function	Max./Min. reset		Max./Min. reset		
9	Measurement display ON/OFF	Phase voltage	ON		OFF		
		Line voltage	ON		ON		
		Zero-phase voltage	ON		ON		
		Frequency	ON		ON		
10	Input circuit	Zero-phase input voltage	190V	110V	190V	110V	
		Rated frequency	50Hz		50Hz		
11	Measurement	Dead band	0.0%		0.0%		
12	Analog output specification (¹)(³)		1 to 5V		1 to 5V		
13	Analog output adjustment (¹)	Output 1	Bias adjustment	0.0%		0.0%	
			Span adjustment	100.0%		100.0%	
		Output 2	Bias adjustment	0.0%		0.0%	
			Span adjustment	100.0%		100.0%	
		Output 3	Bias adjustment	0.0%		0.0%	
			Span adjustment	100.0%		100.0%	
		Output 4	Bias adjustment	0.0%		0.0%	
			Span adjustment	100.0%		100.0%	

Note(¹) A setting item is not displayed in case there is no corresponding option.

Note(²) It becomes the next function in case there is no alarm output option.

Input 1 function : Max. / Min. reset, Input 2 function : Measurement factor change.

Note(³) A setting item is not displayed if analog output is except DC0 to 5V (or DC1 to 5V) specification.

■ Explanation of LCD

This product (hardware model D) has the part displayed in Japanese.

Please refer to explanation of a display.

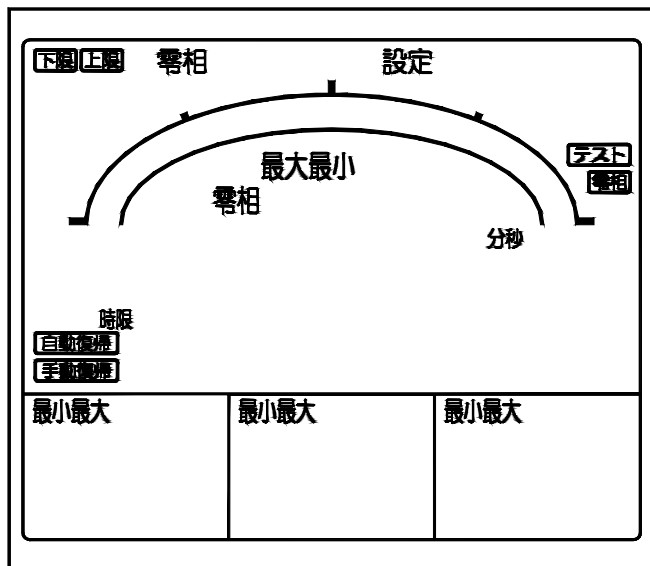

下限 : Lower limit
 上限 : Upper limit
 設定 : Set
 テスト : Test
 零相 : Zero-phase
 最大 : Maximum
 最小 : Minimum
 分 : Minute
 秒 : Second
 時限 : Time interval
 自動復帰 : Automatic reset
 手動復帰 : Manual reset

Content

1. Product outline 5
 1.1 Usage of product 5
 1.2 Features of product 5

2. The name and function of each part 6

3. Preparation
 3.1 Installation 7
 3.2 Connections 8

4. Operation 9
 4.1 The screen change and function by switch operation 10
 4.2 The kind of display 11
 4.2.1 Measurement display 11
 4.2.2 Alarm detection display 13
 4.2.3 Setting display 14
 4.3 Operation 15
 4.3.1 The main monitor display-element change 15
 4.3.2 Phase (line) display change 15
 4.3.3 Ground fault phase detection display change 16
 4.3.4 Setting value check 16
 4.3.5 Setting mode 17
 4.3.6 Reset 18

5. Setting
 5.1 Function table 20
 5.2 Setting table 22
 5.3 Setting in detail explanation 26
 5.3.1 Setting mode 1 26
 5.3.2 Setting mode 2 31
 5.3.3 Setting mode 3 36

6. Specification
 6.1 Specification and intrinsic error 38
 6.2 Performance 39
 6.3 Option 40

7. Maintenance and check
 7.1 Trouble shooting 42
 7.2 Test 42

1. Product outline

1.1 Usage of product

This single unit can measure and monitor phase voltage $\times 3$, line voltage $\times 3$, zero-phase voltage, frequency. 3-phase voltage can select two types, a phase voltage input product and a line voltage input product, according to a usage. Distinction of ground fault phase can be performed by zero-phase voltage and phase voltage. The intensive monitor united with the system is made in an addendum of analog output.

1.2 Features of product

- Phase voltage input product can distinguish the ground fault phase at the case of ground fault occurrence by measuring zero-phase voltage and a phase voltage.
- Bar graph 1 measurement and digital 4 measurement are displayed simultaneously.
- Analog output 4 circuit and alarm output 2 circuit can be taken out. (Option)
And, an output factor can be selected by setting.
- Two external operation inputs are possible. (Option)
And, selection of reset input and a display change input is possible at setting.
- Power supply is AC85 to 264V, DC80 to 143V (for both AC and DC uses).
- The mounting method of this unit is compatible with the mounting method of conventional 110 square mechanical meter. This unit is mounted at 2 diagonal points.
- Setup of the measurement response time is possible for a phase voltage and zero-phase voltage. (High-speed 0.05 to 5 seconds. Arbitrary settings.)
- Demand time interval setting is possible for a line voltage.
- The function which changes a measurement display to a maximum of zero-phase voltages and the minimum voltage of each phase automatically at the case of ground fault detection is attached. (Function ON / OFF is possible at a setting)
- Analog output is with a lower limit limiter.
- The backlight function is equipped (White LED backlight).
Selection of backlight on, backlight off, and auto backlight off and setting of brightness are possible.

2. The name and function of each part

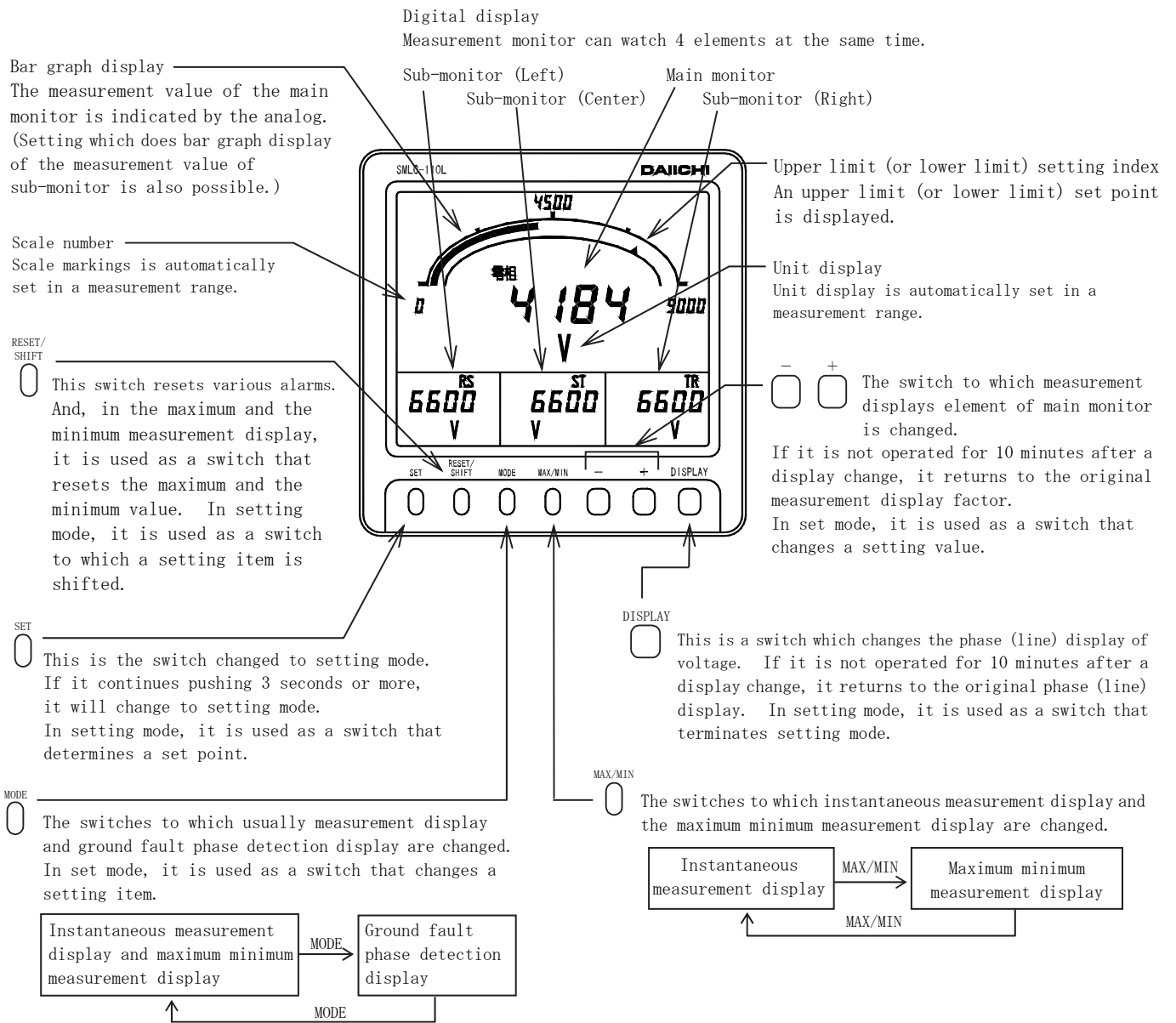

3. Preparation

3.1 Installation

Mount the unit by the attached M5 nuts to a panel of thinner than 10mm, referring to the following external dimensions drawing and panel cutout. Fasten these nuts with tightening torque 2.0 to 2.5N·m.

● Dimension diagram

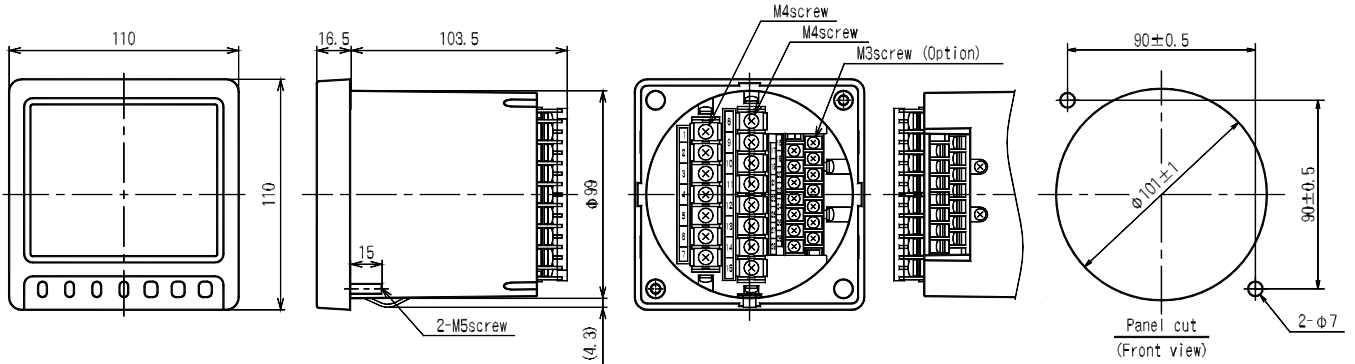

● Mounting position

The contrast of the liquid crystal display changes depending on the viewing angle, so install it at the optimum angle.

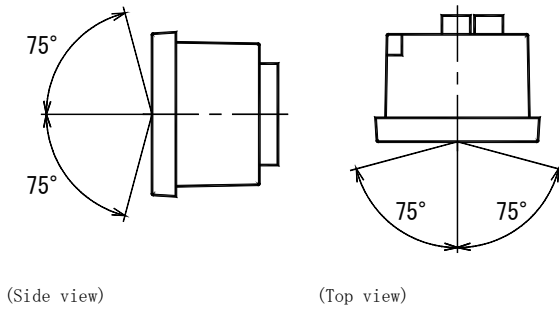

● Installation

- (1) A product is put in a cut hole of a panel from a front. A body is inserted until it exceeds retaining stopper of the lower base.
- (2) Please fix a product certainly with attached M5 flange nut for installation. Please give a tightening torque as 2.0 to 2.5N·m.

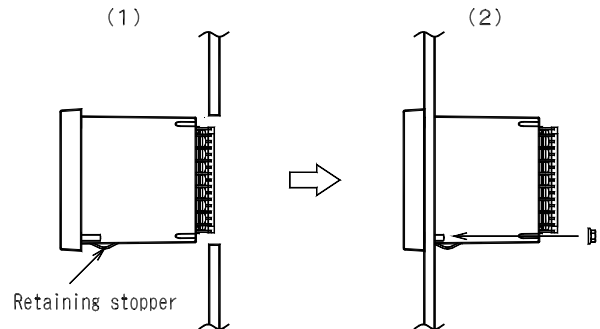

3.2 Connections

Please perform connection after referring to the following wiring diagram.

■ Connection drawing (6)

- 3-phase voltage (Phase voltage input),
Zero-phase voltage

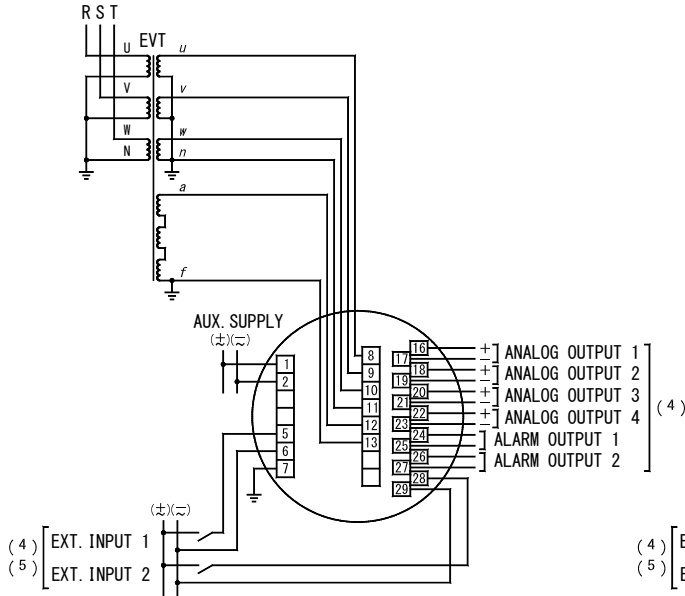

- 3-phase voltage (Line voltage input),
Zero-phase voltage (7)

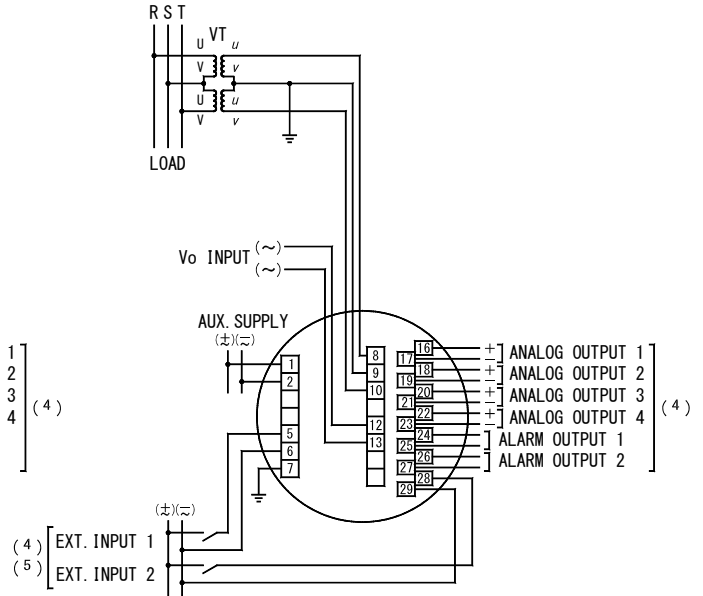

Note(4) Analog output, alarm output, external operation input is an option.

Note(5) Can change to external reset function or external display change function by setting.

Note(6) In case of low-voltage circuit, secondary side grounding of VT is unnecessary.

Note(7) If a 3-phase voltage input is line voltage input specification, phase voltage measurement is OFF and it cannot perform the check of a ground fault phase.

Grounding except S phase (R, T phase, or neutral point) does not have a problem on characteristics.

● Caution on connection

- (1) Mount the terminal cover without fail for safety after the end of connections.
- (2) Separate the input wiring and output wiring from each other without fail, and take a preventive measure against malfunction due to external noises.
- (3) Connect the grounding terminal E (No. 7 terminal) to the ground without fail for enhancing the shield effect. Keep the grounding resistance between the grounding terminal and the ground to be lower than 100Ω.
- (4) Keep a distance of more than 30cm between this unit and the circuit breaker as well as between this unit and the relay contact signal line.
- (5) No protection is necessary for this unit even if the transmission line may be affected by an induced lightning surge or the like when transmitting an analog output to the receiver. Mount an about 500V arrester or the like between the line surge protector and the ground as well as between the transmission line and the ground on the receiver side for the purpose of protecting the devices on the receiver side.
- (6) We recommended to mount a surge killer outside when connecting an inductive load to the alarm output. If no surge killer is mounted, the contact life may shorten.

4. Operation

- The function of switch

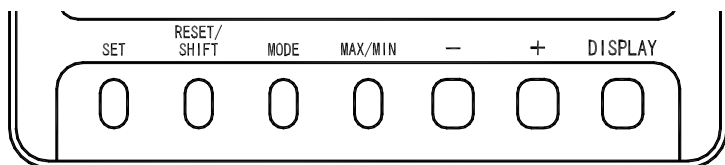

Switch	Function
SET	If it continues pushing 3 seconds or more, it will change to setting mode. In setting mode, it is used for the determination of a set point.
RESET/SHIFT	Various kinds of alarms are reset. The maximum value and the minimum value are reset in the maximum minimum measurement display. In setting mode, it is used for movement of a setting item.
MODE	The instantaneous measurement display and maximum (minimum) measurement display and ground fault phase detection display is changed. In setting mode, it is used for the change of a setting item.
MAX/MIN	The instantaneous measurement display and maximum (minimum) measurement display is changed.
+ , -	The measurement display element of the main monitor is changed. In setting mode, it is used for change of a set point.
DISPLAY	A phase (between lines) display of current (voltage) is changed. It is used in case it terminates setting mode. And, it is used in case it returns the display combination of a measurement factor.

- Convenient functions

- (1) In case a measurement change or a phase change is performed and the original screen composition is not clear anymore, DISPLAY is pushed for more than 3 seconds or it's no operation for 10 minutes and returns to original screen structure.
- (2) Even if it stops operation with setting mode, it returns to the display mode in 10 minutes.

- 7 segment displays

This product shows the guidance in various setting using 7 segment displays besides a display of a measurement value. A digital readout and 7 segment displays corresponding to each alphabet are shown in the following.

A	B(b)	C	D(d)	E	F	G	H	I	J	K	L	M
A	b	C	d	E	F	G	H	I	No display	No display	L	M
N(n)	O(o)	P	Q(q)	R(r)	S	T(t)	U(u)	V	W	X	Y(y)	Z
n	o	P	q	r	S	t	u	v	w	No display	y	z
0	1	2	3	4	5	6	7	8	9			
0	1	2	3	4	5	6	7	8	9			

4.1 The screen change and function by switch operation

This product changes various screens by switch operation. Here, the change step of the screen by switch operation is explained.

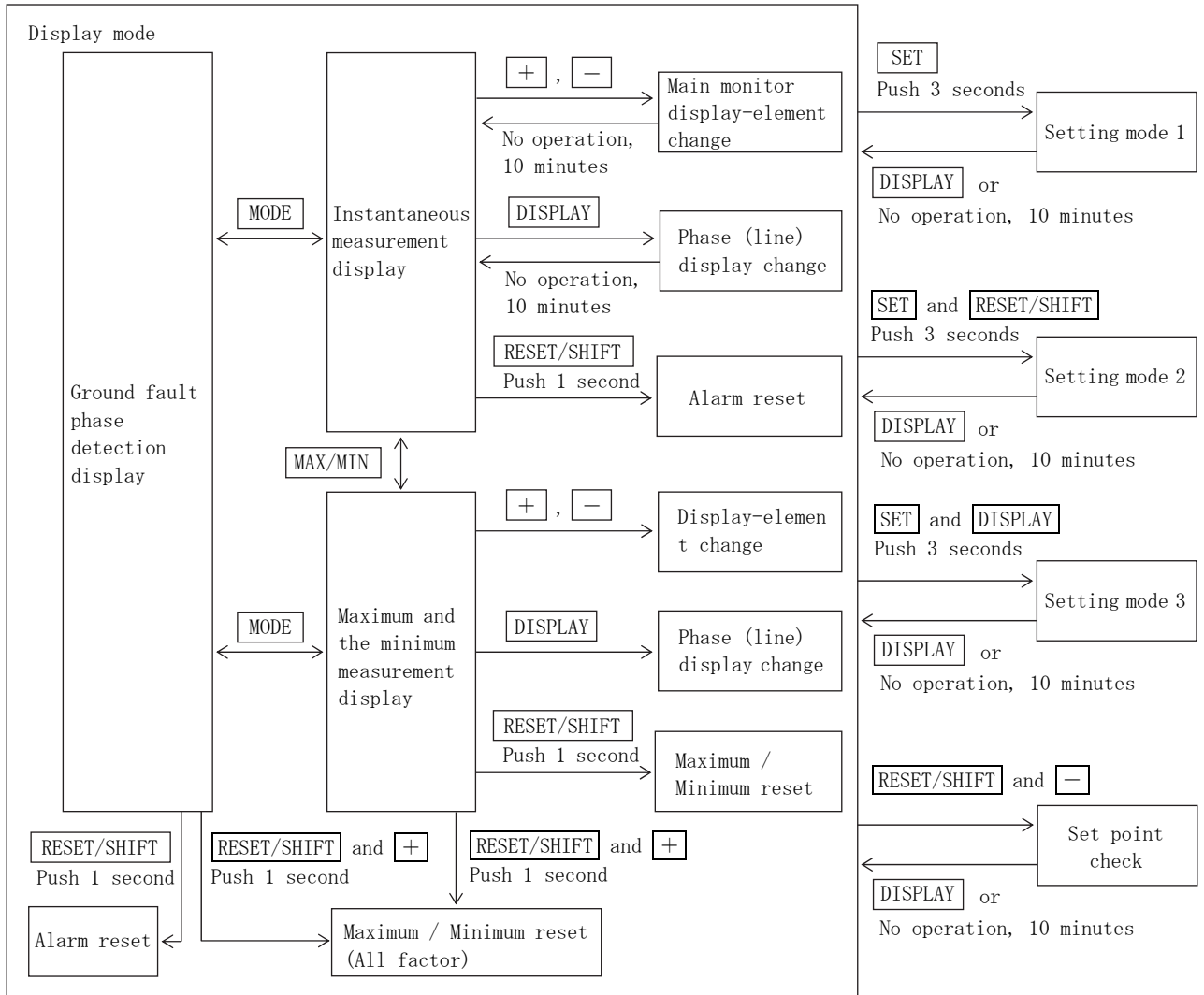

4.2 The kind of display

4.2.1 Measurement display

A measurement value display has the two following types of displays.

The change of the measurement display element of the main monitor by switch operation and the change of the phase / line display of voltage is possible (temporarily).

In an instantaneous measurement display, if switch operation is not performed for 10 minutes after changing a display element, it returns to the original measurement display element automatically.

① Measurement display

Measurement factors, such as 3-phase voltage, zero-phase voltage, and frequency, are displayed.

The measurement value of four factors is displayed at the maximum.

Setting which always displays a measurement factor is possible. And, it is possible to change to a display of the maximum value and the minimum value, about the measurement factor which performs holding of the maximum value and the minimum value by switch operation.

These maximum values and the minimum value are reset by switch operation (it updates to the instantaneous value at the time). In addition, as for the maximum value and the minimum value, power supply reset is not cleared either. And, this display is held by even after 10 minutes of switch no operation.

Zero-phase voltage display

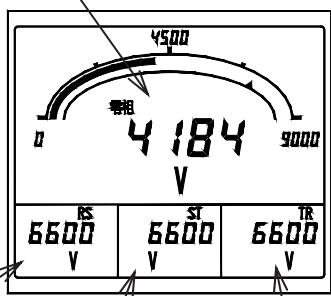

V(RS) display V(ST) display V(TR) display
Instantaneous measurement display

Range of minimum to maximum is displayed in bar graph.

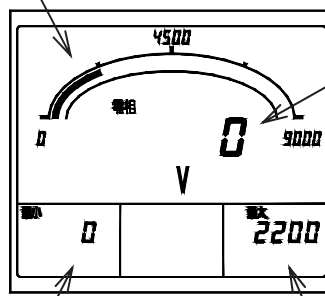

Minimum display Maximum display
Maximum and minimum measurement display

Instantaneous display

• The example of a measurement display of each measurement factor (Main monitor)

Measurement factor	Example of display	Note	Measurement factor	Example of display	Note
Line voltage			Phase voltage		
Zero-phase voltage		“ZERO PHASE <零相>” is display	Maximum zero-phase voltage		“MAX. <最大>” and “ZERO PHASE <零相>” is display
Frequency					

② Ground fault phase detection display

The maximum zero-phase voltage and the minimum phase voltage of each phase are displayed. (Display-element fixation)
 It is possible to distinguish the ground fault phase at the case of ground fault occurrence by displaying these measurement values. As for this display, power supply reset is also held. And, each maximum value and the minimum value are always updated by the newest value. However, about line voltage input product, a phase voltage is OFF. The change by switch operation and the automatic change at the case of the ground fault detection by setup are possible for the change to this display.

The change to this display has the next method. The change by switch operation, and the automatic change at the case of the ground fault detection by setup.

In addition, in case a backlight setup changes to a ground fault phase detection display automatically by ground fault detection by "OFF", backlight turn on the lights at the same time a screen is changed. (After that, in case it does not operate it for 5 minutes, backlight goes out.)

Please refer to "4.3.3 Ground fault phase detection display change" about switch operation. And about the automatic change setting method, please refer to "5.3.1 setting mode 1 (4) zero-phase voltage detection setting".

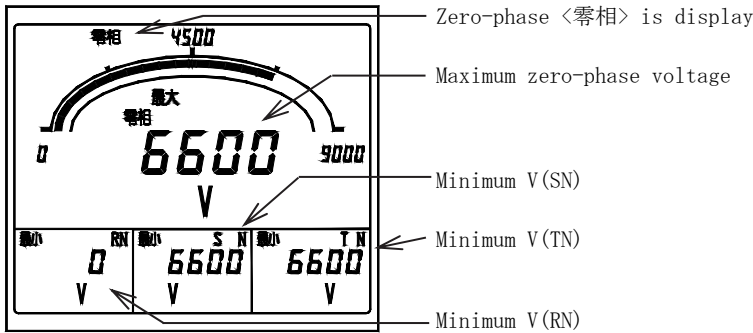

Ground fault phase detection display

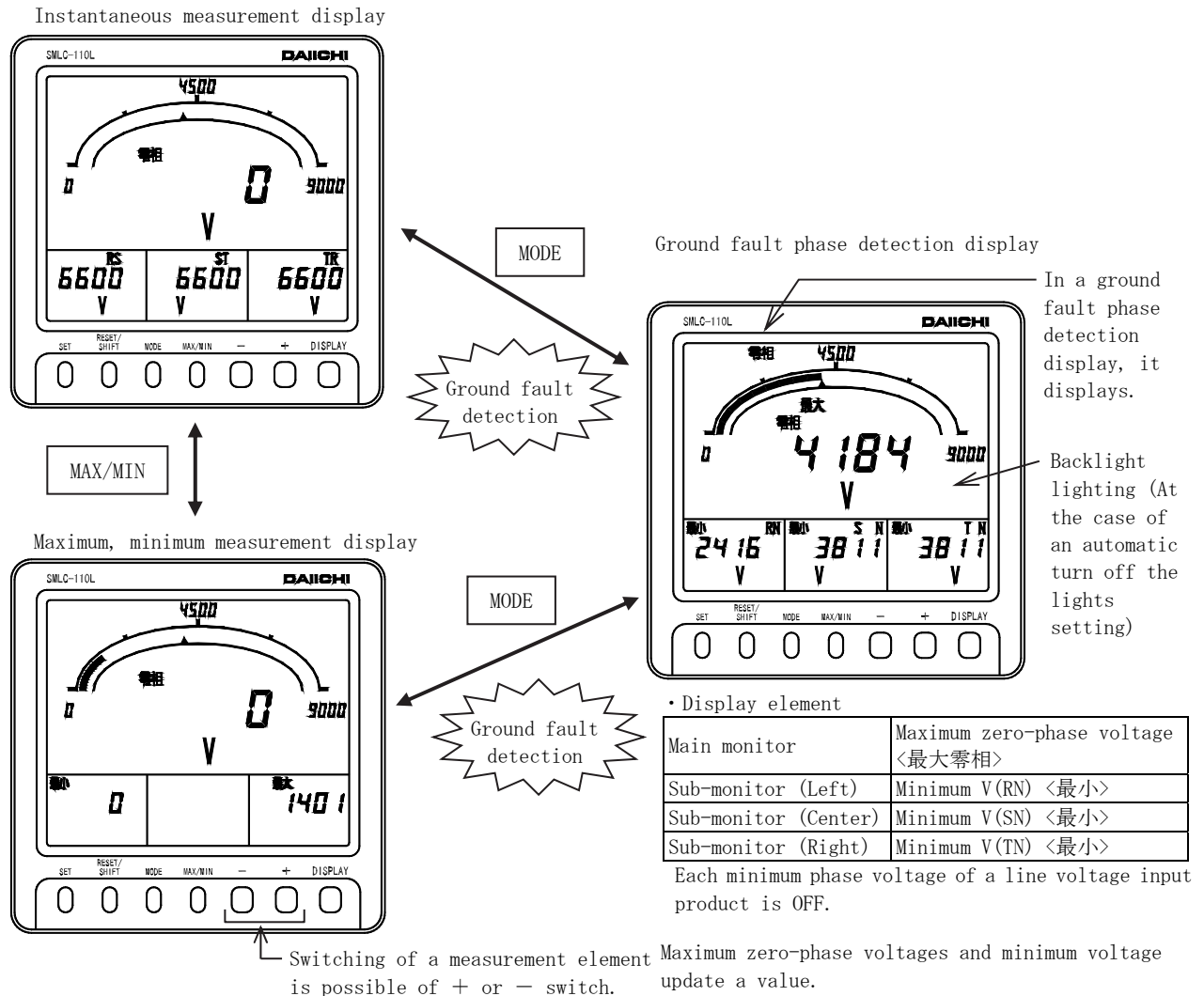

4.2.2 Alarm detection display

The alarm value setting is a possible measurement factor (zero-phase voltage and line voltage), it displays in case an input exceeds a set point.

Besides the usual measurement display, the detected factor is displayed on a screen upper case.

In addition, in case setting OFF (not use) as measurement factor, it does not detect.

And in the case of with an alarm output option, it is possible to do an alarm output (relay make contact) to the outside simultaneously with a screen display.

Alarm display possible factor) Zero-phase voltage, Line voltage (the maximum value between each line),

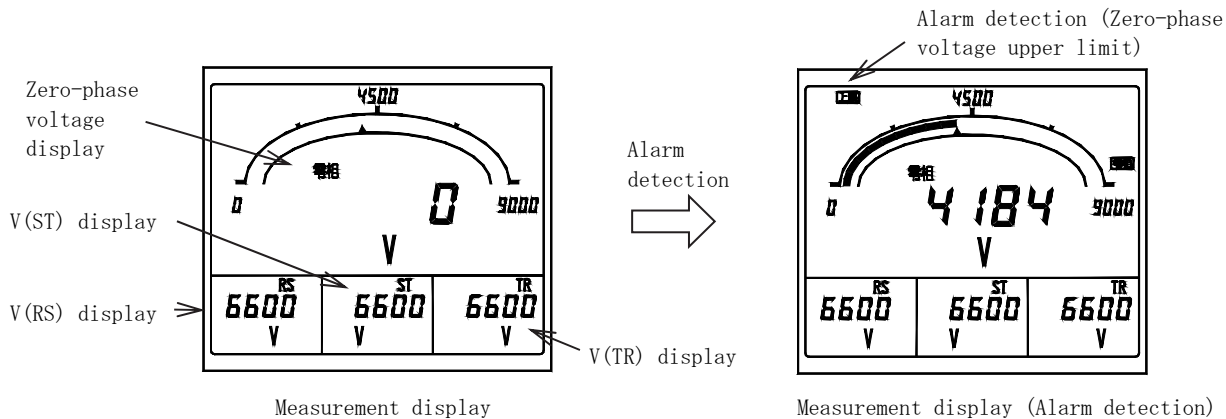

- The example of a display at the case of the detection in each alarm factor.
- In case the alarm factor is indicating by measurement at the main monitor or the sub-monitor, a measurement value constitutes a blinking display.
- The displays after an alarm return.
- In case a return method is automatic reset setting : It returns to the usual measurement display.
- In case a return method is manual reset setting : A detection display and an alarm output hold (in case setting as an alarm output of applicable factor).
- The return in this case needs alarm reset operation. Please refer to "4.3.6 Reset" about alarm reset.

Alarm factor	Example of a display	Alarm factor	Example of a display
Line voltage Upper limit (H) <上限>	<p>Detection display</p> <p>High-alarm (H) set point</p> <p>Low-alarm (L) set point</p>	Zero-phase voltage Lower limit (L) <下限>	<p>Detection display</p> <p>High-alarm (H) set point</p> <p>Low-alarm (L) set point</p>
Zero-phase voltage Upper limit (H) <上限>	<p>Detection display</p> <p>High-alarm (H) set point</p>		

4.2.3 Setting display

This is display for various setting. There are three types of setting modes according to the contents of setting. Refer to "5. Setting" for the operation in setting mode, and the detailed contents of a setting.

① Setting mode 1

Setting of a measurement display element, an alarm output, and an alarm value is mainly performed.

And, an alarm output can be tested in this setting mode.

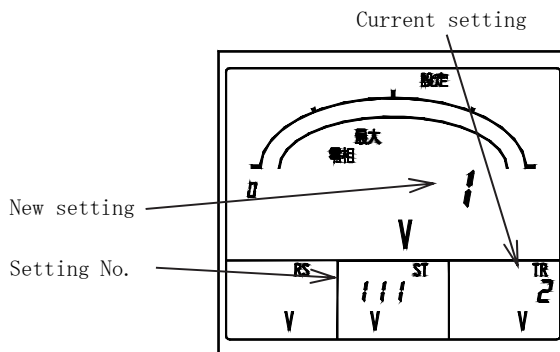

Setting mode 1 (No.111 Display pattern)

② Setting mode 2

Setting of measurement range, analog output, and measurement display ON/OFF is mainly performed.

And, initialization of a setting value can be performed in this setting mode.

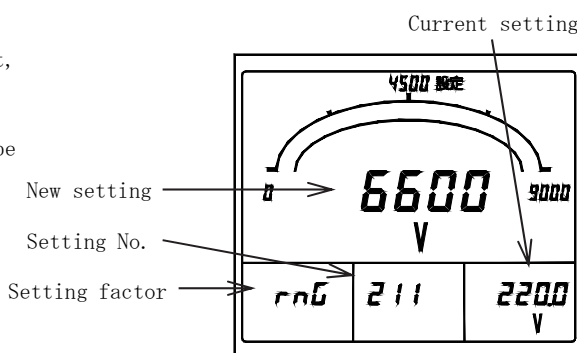

Setting mode 2 (No.211 Voltage range)

③ Setting mode 3

Setting of input circuit is mainly performed.

And, analog output can be adjusted in this setting mode.

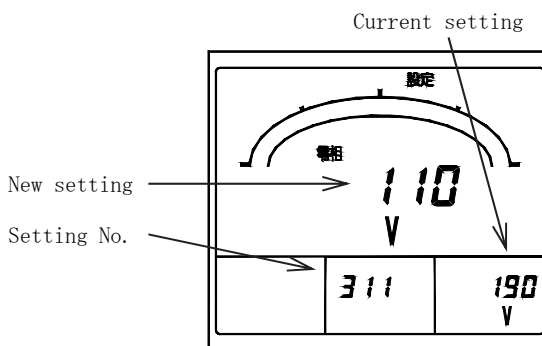

Setting mode 3
(No.311 Input circuit zero-phase input voltage)

4.3 Operation

4.3.1 The main monitor display-element change

The measurement display element of the main monitor is changed. A change is performed by $\boxed{+}$ $\boxed{-}$. This operation can perform the maximum and the minimum display other than instantaneous measurement display. After changing a measurement display element, if a switch is not operated for 10 minutes, it will return to the original measurement display element automatically. In maximum display and minimum display, even if a switch is not operated for 10 minutes, it does not return to the original display. Setting can perform same operation in external operation input. Please refer to "5.3.2 Setting mode 2, (3) external operation input setting" about the setting method. Please refer to "6.3 Option" about external operation input.

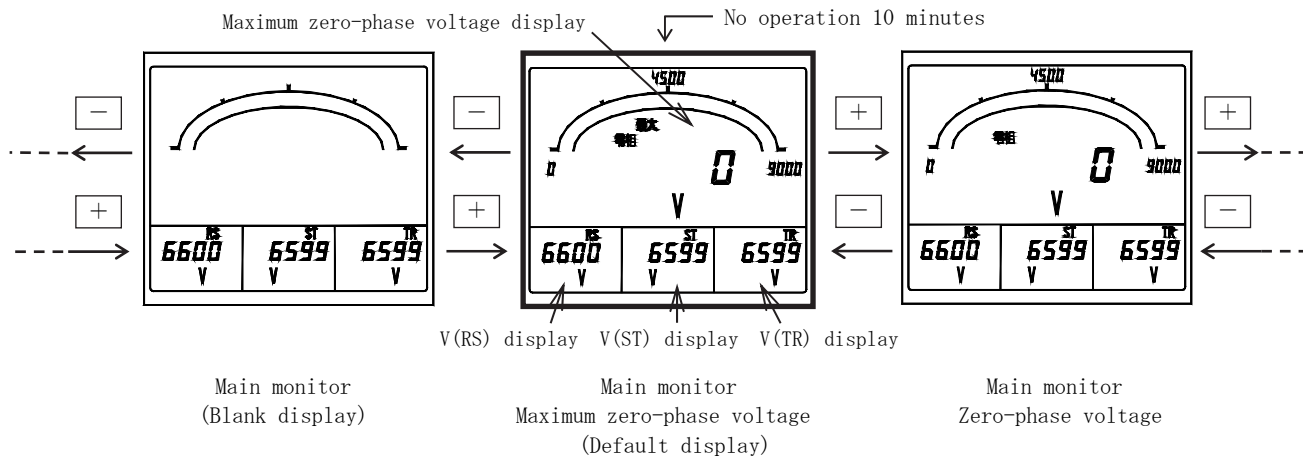

4.3.2 Phase (line) display change

A phase (line) display of voltage is changed. (Everything which is being indicated) A change is performed by $\boxed{\text{DISPLAY}}$. This operation can perform the maximum and the minimum display other than instantaneous measurement display. In addition, after changing a phase (line) display, if a switch is not operated for 10 minutes, it will return to the original phase (line) display automatically. In maximum display and minimum display, even if a switch is not operated for 10 minutes, it does not return to the original display. Setting can perform same operation in external operation input. Please refer to "5.3.2 Setting mode 2, (3) external operation input setting" about the setting method. Please refer to "6.3 Option" about external operation input.

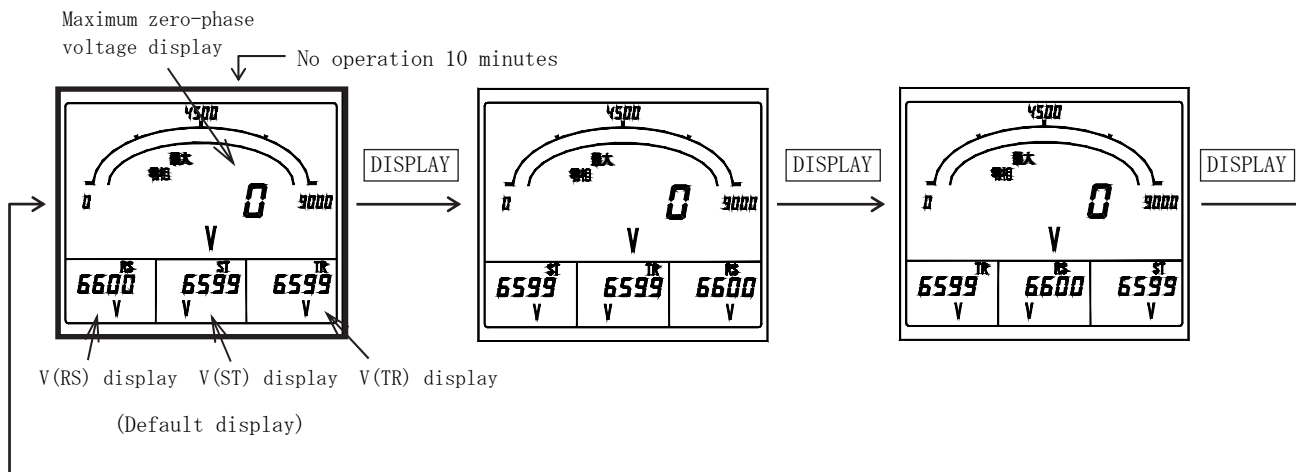

4.3.3 Ground fault phase detection display change

A measurement display and a ground fault phase detection display are changed. A change is performed by **MODE**. This operation can perform the maximum and the minimum display other than instantaneous measurement display. In addition, even if it elapses for 10 minutes without operating a switch, it does not return to the original display. And, a display is held even if it performs power supply reset. And, each maximum value and the minimum value are always updated by the newest value. Besides switch operation, it can change to a ground fault phase detection screen automatically by setup at the case of ground fault phase detection. Please refer to "5.3.1 Setting mode 1 (4) zero-phase voltage detection setting" about the setting method.

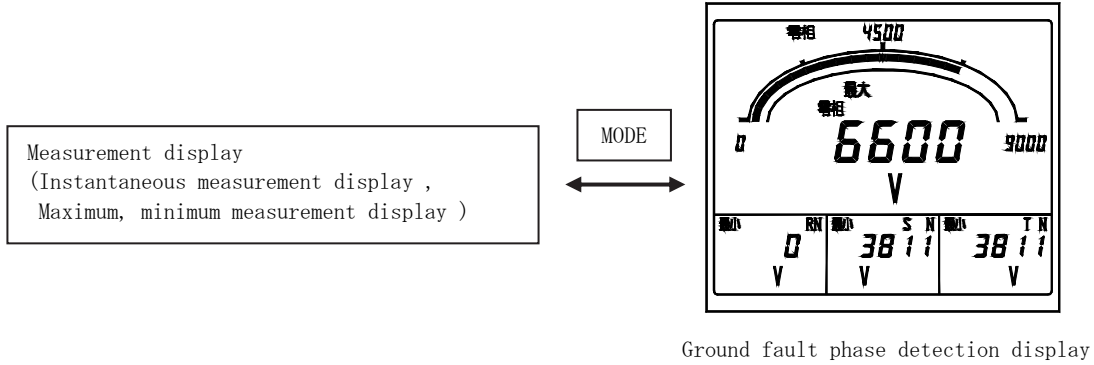

- * A ground fault phase constitutes the minimum value of a RN-SN-TN phase voltage. However, if a high order circuit breaker is switched OFF at the case of zero-phase voltage detection, all the minimum values of RN-SN-TN will be 0V. In that case, please check a ground fault phase at the maximum value of RN-SN-TN phase voltage.

4.3.4 Setting value check

A voltage range (VT ratio) and an alarm output set point are checked. Check is **RESET/SHIFT** and **-** are pushed simultaneously and performed. The change of a set point is carries out by **+** and **-**. This operation can perform a ground fault phase detection display and the maximum and minimum display other than a general measurement display. **DISPLAY** is pushed in case it returns to the original measurement display. And, if a switch is not operated for 10 seconds after a set point check, it will return to the original measurement display automatically.

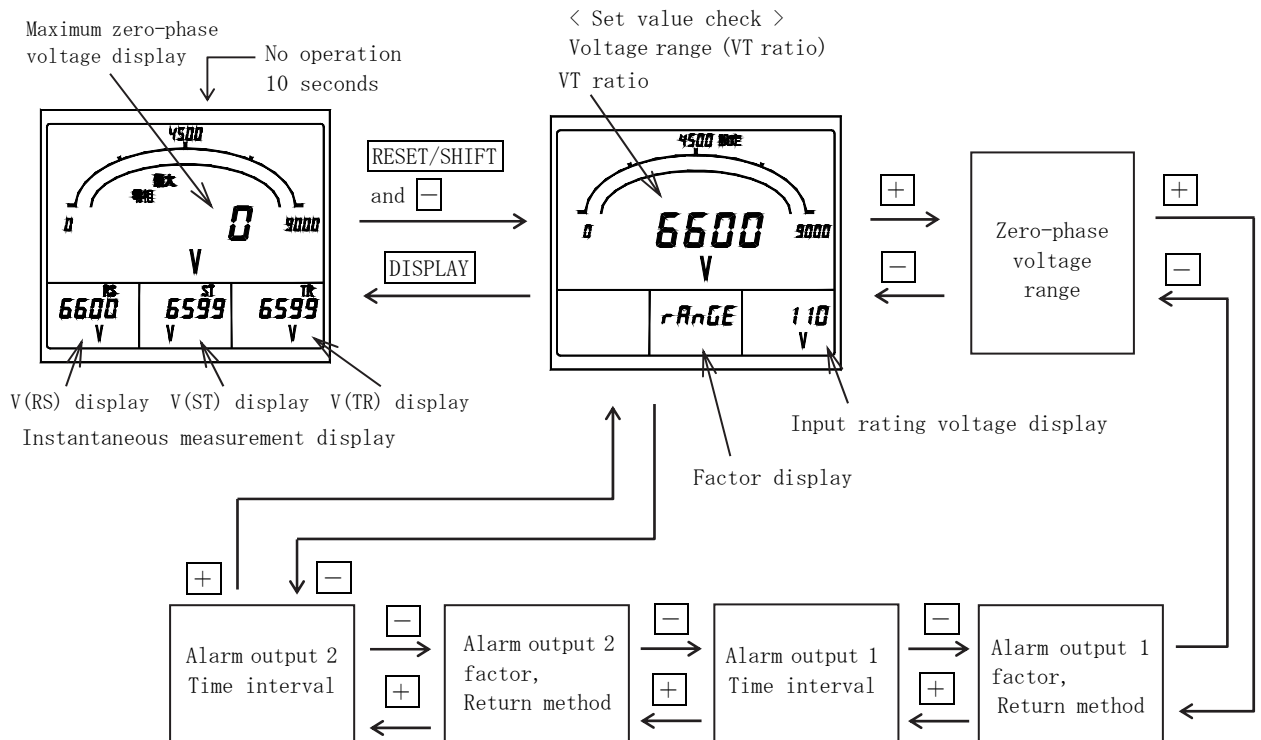

4.3.5 Setting mode

Various kinds of setting are performed. Setting mode is three types, and operations are different. **DISPLAY** is pushed in case it returns to the original measurement display. And, if a switch is not operated for 10 minutes after a set point check, it will return to the original measurement display automatically. Operation and the contents of setting (detail) in setting mode, please refer to "5 Setting".

- Setting mode 1 : Press **SET** for longer than 3 seconds.
- Setting mode 2 : Press **SET** and **RESET/SHIFT** together for longer than 3 seconds.
- Setting mode 3 : Press **SET** and **DISPLAY** together for longer than 3 seconds.

<Reference> This operation can perform the maximum, the minimum display, and a ground fault phase detection display besides an instantaneous measurement display.

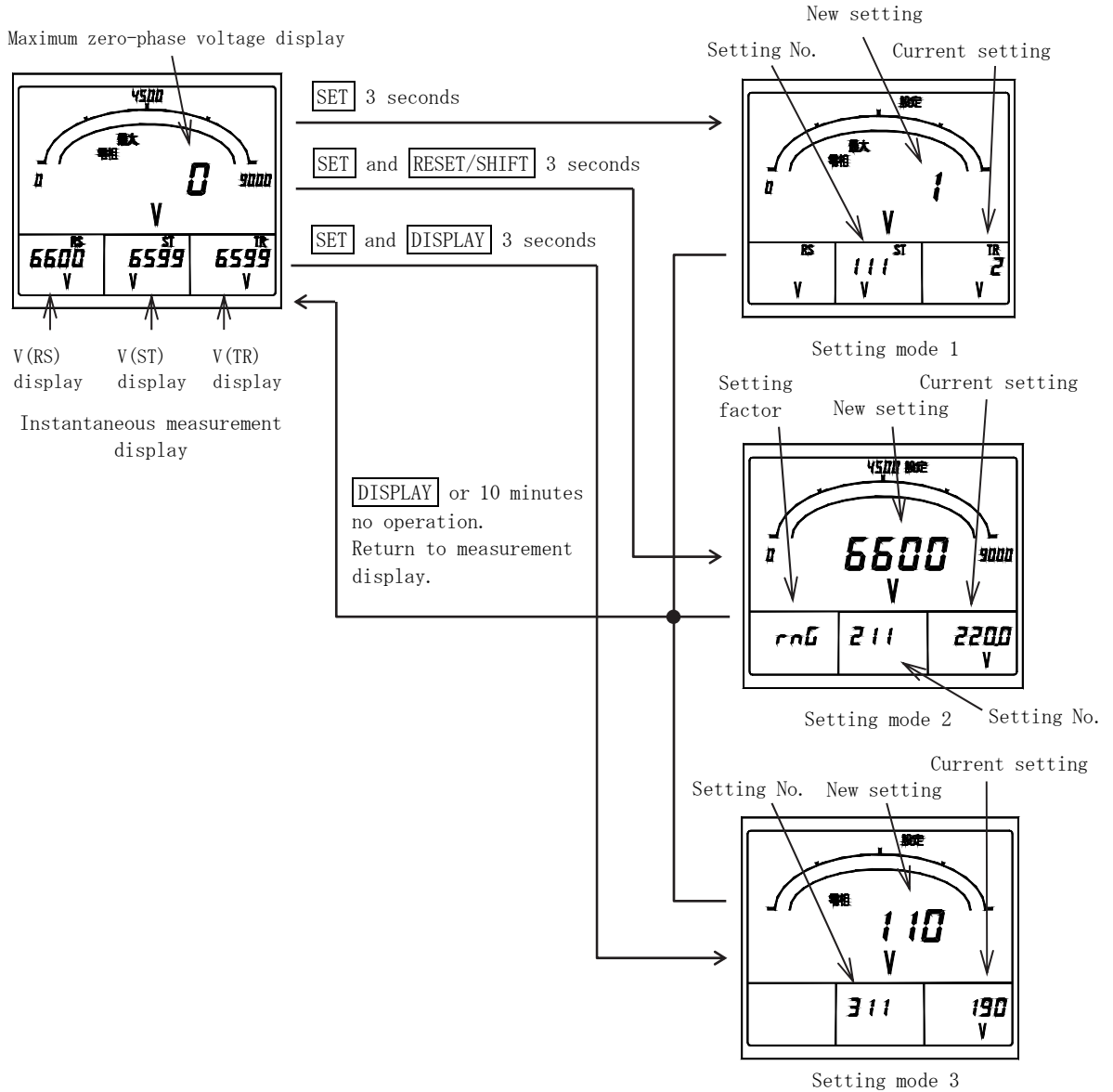

4.3.6 Reset

Various kinds of reset are performed. The kind of reset is as follows and operations are different, respectively. Reset of maximum value and minimum value (it updates to the instantaneous value at the time), Alarm output reset (OFF of an alarm output (at the case of manual reset setting)). And, the operation from each measurement display constitutes conditions at each reset.

(1) Reset of maximum value and minimum value

Reset of the various measurement values of maximum value and minimum value is performed. This reset has two types of methods. (How to perform according to a measurement factor individual. How to reset all maximum values and minimum values by package.)

<Caution> After a startup, needed is reset of maximum value and minimum value.

a) Individual reset

Reset of only a certain differential maximum value or the minimum value is performed. Other maximum values and minimum values are not reset by this operation.

- ① A measurement factor to reset is displayed. (Maximum value, minimum value display)
- ② Press **RESET/SHIFT** for longer than 1 seconds.

<Caution> An alarm output will be reset if this operation is performed by instantaneous measurement display. Please be sure to perform this operation after displaying the maximum value and a minimum value measurement factor to make it reset.

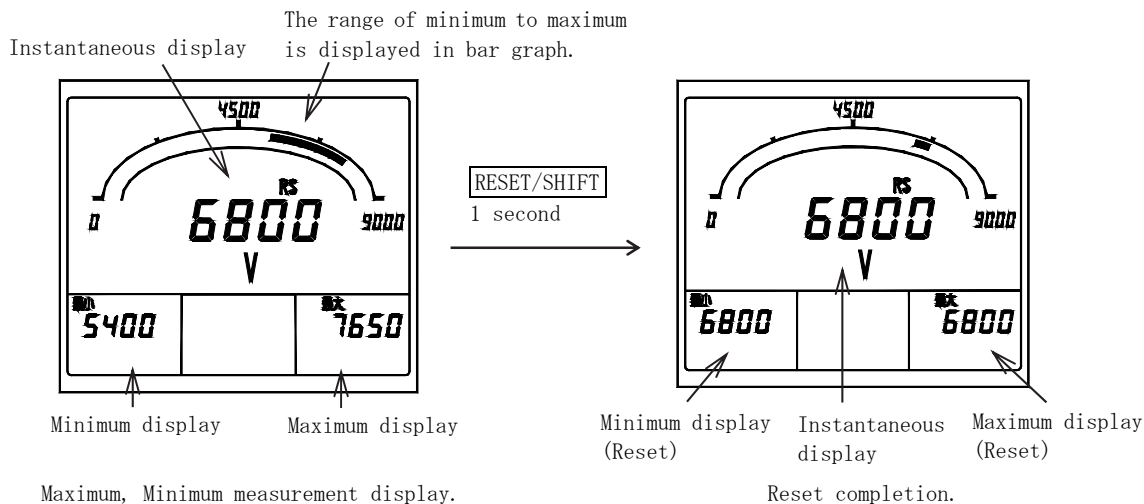

b) Package reset

Reset of all the maximum values and minimum value is performed. In addition, setting can perform same operation in external operation input. Please refer to "5.3.2 Setting mode 2 (3) external operation input setting" for the setting method, Please refer to "6.3 Option" for the external operation input,

- ① Press **RESET/SHIFT** and **+** together for longer than 1 second. By the maximum and the minimum measurement display and ground fault phase detection display.

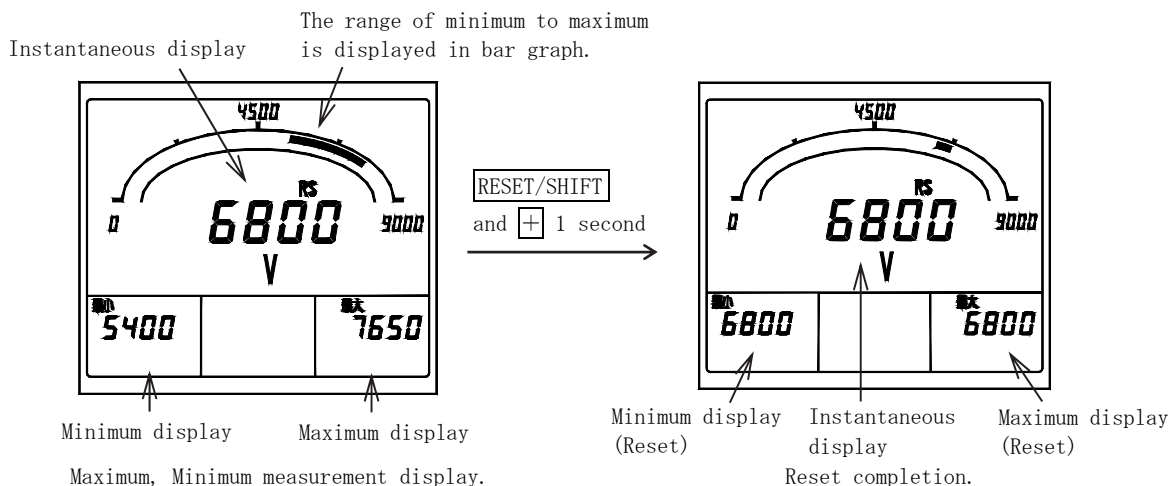

(2) Alarm reset

In case an alarm return method is set to "HOLD (manual return)", an alarm output is reset (output OFF).
 (With an alarm output option)

However, an output is not turned off by this operation, in case an alarm continues and it has caused.
 And, this operation is unnecessary in case setting as "AUTO (automatic return)" in alarm return method.
 (By which an output is also OFF according to an alarm return.)

In case the number of alarm outputs is two, both outputs are reset (output OFF) by this operation.
 (Return operation that comes out individually cannot be performed.)

In addition, setting can perform same operation in external operation input.

Please refer to "5.3.2 Setting mode 2 (3) external operation input setting" for the setting method,

Please refer to "6.3 Option" for the external operation input,

- ① By An instantaneous measurement display or ground fault phase detection display, RESET/SHIFT is pushed 1 second or more.

<Caution> If this operation is performed by the maximum and the minimum measurement display, the maximum value and minimum value of the measurement factor currently displayed will be reset.
 Please be sure to perform this operation in the state of an instantaneous measurement display or ground fault phase detection display.

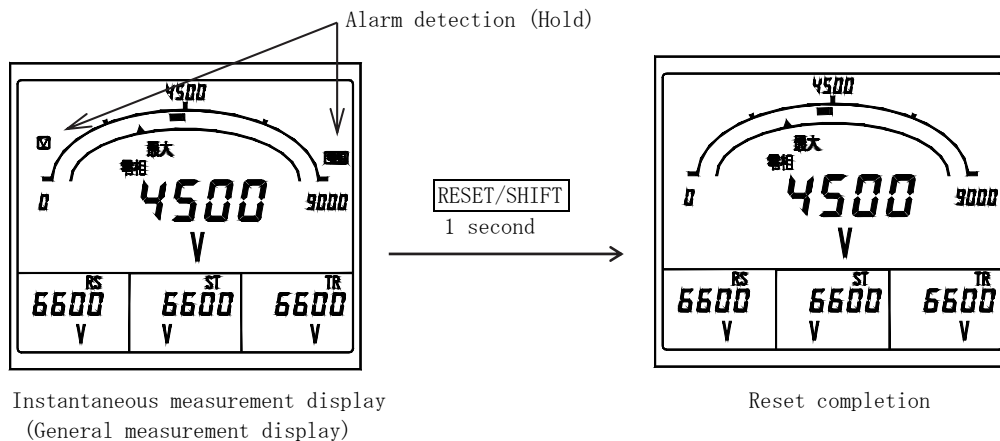

5. Setting

5.1 Function table

This product has each function setting with a front switch.

Setting mode 1. Function table

Set No.	Function	Functional description	Default setting	Important setting	Page
111	Display pattern	Set the display combination pattern of the digital 4 displays and bar graph display.	Pattern 1	○	26, 27
112	Main monitor	Set the display factor of digital main monitor.	MVo	○	26, 27
113	Sub-monitor (left)	Set the display factor of digital sub-monitor (left).	V(RS)	○	26, 27
114	Sub-monitor (center)	Set the display factor of digital sub-monitor (center).	V(ST)	○	26, 27
115	Sub-monitor (right)	Set the display factor of digital sub-monitor (right).	V(TR)	○	26, 27
116	Bar graph	Set the display factor of bar graph.	MVo+Vo	○	26, 27
121AL ⁽⁸⁾	Alarm 1 factor	Set the output factor of alarm 1.	Vo	○	28
122AL ⁽⁸⁾	Alarm 1 return method	Set the output action at the case of reset of alarm 1.	Automatic reset		28
123AL ⁽⁸⁾	Alarm 1 test	Output test of alarm 1 is performed.	—		28
124AL ⁽⁸⁾	Alarm 2 factor	Set the output factor of alarm 2.	OFF	○	28
125AL ⁽⁸⁾	Alarm 2 return method	Set the output action at the case of reset of alarm 2.	Automatic reset		28
126AL ⁽⁸⁾	Alarm 2 test	Output test of alarm 2 is performed.	—		28
131H	3-phase voltage upper limit	Set the high-alarm value of 3-phase voltage.	OFF		29
132L	3-phase voltage lower limit	Set the low-alarm value of 3-phase voltage.	OFF		29
133	Demand time interval	Set the demand time interval of line voltage.	0 second	○	29
141H	Zero-phase voltage upper limit	Set the high-alarm value of zero-phase voltage.	5280V	○	30
142	Response time	Set the measurement response time of zero-phase voltage.	0.1 seconds	○	30
143	Ground fault phase detection display ON/OFF	At the case of ground fault detection, it sets whether a screen is automatically changed to a ground fault phase detection display.	OFF	○	30
151	Backlight action	Set the ON/OFF of backlight.	AUTO OFF	○	31
152	Backlight brightness	Set the brightness of backlight.	3 (Middle)	○	31

Note⁽⁸⁾ A setting item is not displayed in case there is no corresponding option.

Setting mode 2. Function table

Set No.	Function	Functional description	Default setting	Important setting	Page
211	Voltage range	Set the voltage measurement range (VT ratio).	6600V	○	32
212	Zero-phase voltage scale	Display ON/OFF of $\times 1/\sqrt{3}$ is set as a scale of zero-phase voltage.	$\times 1/\sqrt{3}$ display OFF	○	32
213	Frequency range	Set the full scale of frequency meter. And, set this output range of analog output.	45.0 to 65.0Hz		32
221A ⁽⁹⁾	A01 output factor	Set the output factor of A01 (analog output 1).	MVo	○	33
222A ⁽⁹⁾	A02 output factor	Set the output factor of A02 (analog output 2).	V(RS)	○	33
223A ⁽⁹⁾	A03 output factor	Set the output factor of A03 (analog output 3).	V(ST)	○	33
224A ⁽⁹⁾	A04 output factor	Set the output factor of A04 (analog output 4).	V(TR)	○	33
225A ⁽⁹⁾	Low input cut	Set the function which makes a lower limit the output at the case of small input (3-phase voltage is 0.5% or less. zero-phase voltage is 1.0% or less) in analog output.	OFF (No operation)		33
231 ⁽⁹⁾	External operation input 1 function	Set the function of the external operation input 1.	Alarm reset ⁽¹⁰⁾	○	34
232 ⁽⁹⁾	External operation input 2 function	Set the function of the external operation input 2.	Maximum / Minimum reset ⁽¹⁰⁾	○	34
241	Phase voltage ON/OFF	Set the ON/OFF of phase voltage measurement display.	ON ⁽¹¹⁾		35
242	Line voltage ON/OFF	Set the ON/OFF of line voltage measurement display.	ON		35
243	Zero-phase voltage ON/OFF	Set the ON/OFF of zero-phase voltage measurement display.	ON		35
244	Frequency ON/OFF	Set the ON/OFF of frequency measurement display.	ON		35
251	Initialization of setting value	All set values are initialized. (Return to initial set value)	—		35

Setting mode 3. Function table

Set No.	Function	Functional description	Default setting	Important setting	Page
311	Zero-phase input voltage	Set the zero-phase input voltage.	190V ⁽¹³⁾	○	36
312	Rated frequency	Set the rated frequency of a zero-phase input is set.	50Hz	○	36
321	Measurement dead band	Set the dead band of measurement display.	0.0%		37
331 ⁽⁹⁾ ⁽¹²⁾	Analog output specification	Set the analog output specification.	DC1 to 5V or DC0 to 5V (Designation)		37
341 ⁽⁹⁾	A01 BIAS adjustment	Set the BIAS value of A01 (Analog output 1).	0.0%		37
342 ⁽⁹⁾	A01 SPAN adjustment	Set the SPAN value of A01 (Analog output 1).	100.0%		37
343 ⁽⁹⁾	A02 BIAS adjustment	Set the BIAS value of A02 (Analog output 2).	0.0%		37
344 ⁽⁹⁾	A02 SPAN adjustment	Set the SPAN value of A02 (Analog output 2).	100.0%		37
345 ⁽⁹⁾	A03 BIAS adjustment	Set the BIAS value of A03 (Analog output 3).	0.0%		37
346 ⁽⁹⁾	A03 SPAN adjustment	Set the SPAN value of A03 (Analog output 3).	100.0%		37
347 ⁽⁹⁾	A04 BIAS adjustment	Set the BIAS value of A04 (Analog output 4).	0.0%		37
348 ⁽⁹⁾	A04 SPAN adjustment	Set the SPAN value of A04 (Analog output 4).	100.0%		37

Note⁽⁹⁾ Setting item is not displayed in case there is no corresponding option.

Note⁽¹⁰⁾ This is initial value with an alarm output option. An initial value when there is no alarm output option constitutes the following.

Input 1 : Maximum / Minimum reset

Input 2 : Measurement factor change

Note⁽¹¹⁾ In the case of line voltage input specification, a initial value constitutes OFF.

Note⁽¹²⁾ Setting item is not displayed other than analog output DC0 to 5V or DC1 to 5V specification.

Note⁽¹³⁾ An initial value is set to 110V in case a zero-phase voltage channel range is 150V.

5.2 Setting table

Setting item changes by the specification of a product, or the existence of an option.

(1) Important setting

Each parenthesized number shows a setting number and this number is displayed on the setting screen.

Items	Setting and operation procedures	Page
Setting of measurement range of voltmeter (211)	Press SET and RESET/SHIFT together for longer than 3 seconds ➡ (211) Select a measurement range by + and - ➡ Press SET ➡ Selected measurement range is entered ➡ Press DISPLAY ➡ Returns to display mode.	32
Setting of zero-phase voltage scale. (212)	Press SET and RESET/SHIFT together for longer than 3 seconds ➡ Press RESET/SHIFT (211) ➡ Select a zero-phase voltage scale by + and - ➡ Press SET ➡ (212) Selected zero-phase voltage is entered ➡ Press DISPLAY ➡ Returns to display mode.	32
Setting of display combination. (111)	Press SET for longer than 3 seconds ➡ Select the display combination by + and - (111) ➡ Press SET ➡ Selected display combination is entered ➡ Press DISPLAY ➡ Returns to display mode.	26, 27
Setting of output factor in analog output 1 (A01). (221A)	Press SET and RESET/SHIFT together for longer than 3 seconds ➡ Press MODE ➡ (211) (221A) Select an output factor by + and - ➡ Press SET ➡ Selected output factor is entered ➡ Press DISPLAY ➡ Returns to display mode.	33
Setting of output factor in analog output 2 (A02). (222A)	Press SET and RESET/SHIFT together for longer than 3 seconds ➡ Press MODE ➡ (211) (221A) Press RESET/SHIFT ➡ Select an output factor by + and - ➡ Press SET ➡ (222A) Selected output factor is entered ➡ Press DISPLAY ➡ Returns to display mode.	33
Setting of output factor in analog output 3 (A03). (223A)	Press SET and RESET/SHIFT together for longer than 3 seconds ➡ Press MODE ➡ (211) (221A) Press RESET/SHIFT ➡ Press RESET/SHIFT ➡ Select an output factor by + and - ➡ (222A) (223A) Press SET ➡ Selected output factor is entered ➡ Press DISPLAY ➡ Returns to display mode.	33
Setting of output factor in analog output 4 (A04). (224A)	Press SET and RESET/SHIFT together for longer than 3 seconds ➡ Press MODE ➡ (211) (221A) Press RESET/SHIFT ➡ Press RESET/SHIFT ➡ Press RESET/SHIFT ➡ (222A) (223A) (224A) Select an output factor by + and - ➡ Press SET ➡ Selected output factor is entered ➡ Press DISPLAY ➡ Returns to display mode.	33
Setting of factor in alarm output 1. (121AL)	Press SET for longer than 3 seconds ➡ Press MODE ➡ Select an factor by + and - (111) (121AL) ➡ Press SET ➡ Selected factor is entered ➡ Press DISPLAY ➡ Returns to display mode.	28
Setting of factor in alarm output 2. (124AL)	Press SET for longer than 3 seconds ➡ Press MODE ➡ Press RESET/SHIFT ➡ (111) (121AL) (122AL) Press RESET/SHIFT ➡ Press RESET/SHIFT ➡ Select an factor by + and - ➡ (123AL) (124AL) Press SET ➡ Selected factor is entered ➡ Press DISPLAY ➡ Returns to display mode	28

Items	Setting and operation procedures	Page
Setting of external operation input 1 function. (231)	Press SET and RESET/SHIFT together for longer than 3 seconds → Press MODE → (211) (221A) Press MODE → Select an function by + and - → Press SET → (231) Selected function is entered → Press DISPLAY → Returns to display mode.	34
Setting of external operation input 2 function. (232)	Press SET and RESET/SHIFT together for longer than 3 seconds → Press MODE → (211) (221A) Press MODE → Press RESET/SHIFT → Select an function by + and - → Press SET → (231) (232) → Selected function is entered → Press DISPLAY → Returns to display mode.	34
Setting of zero-phase input voltage. (311)	Press SET and RESET/SHIFT together for longer than 3 seconds → (311) Select an input voltage by + and - → Press SET → Selected input voltage is entered → Press DISPLAY → Returns to display mode.	36
Setting of rated frequency in zero-phase input. (312)	Press SET and RESET/SHIFT together for longer than 3 seconds → Press RESET/SHIFT → (311) → Select an input rated frequency by + and - → Press SET → (312) Selected input rated frequency is entered → Press DISPLAY → Returns to display mode	36

(2) A combination except a display pattern.

Each parenthesized number shows a setting number and this number is displayed on the setting screen.

Items	Setting and operation procedures	Page
Setting of display factor in main-monitor. (112)	Press SET for longer than 3 seconds → Press RESET/SHIFT → (111) (112) Select an display factor by + and - → Press SET → Selected display factor is entered → Press DISPLAY → Returns to display mode.	26, 27
Setting of display factor in sub-monitor (left). (113)	Press SET for longer than 3 seconds → Press RESET/SHIFT → Press RESET/SHIFT → (111) (112) (113) Select an display factor by + and - → Press SET → Selected display factor is entered → Press DISPLAY → Returns to display mode.	26, 27
Setting of display factor in sub-monitor (center). (114)	Press SET for longer than 3 seconds → Press RESET/SHIFT → Press RESET/SHIFT → (111) (112) (113) Press RESET/SHIFT → Select an display factor by + and - → Press SET → (114) Selected display factor is entered → Press DISPLAY → Returns to display mode.	26, 27
Setting of display factor in sub-monitor (right). (115)	Press SET for longer than 3 seconds → Press RESET/SHIFT → Press RESET/SHIFT → (111) (112) (113) Press RESET/SHIFT → Press RESET/SHIFT → Select an display factor by + and - → (114) (115) Press SET → Selected display factor is entered → Press DISPLAY → Returns to display mode.	26, 27
Setting of display factor in bar-graph. (116)	Press SET for longer than 3 seconds → Press RESET/SHIFT → Press RESET/SHIFT → (111) (112) (113) Press RESET/SHIFT → Press RESET/SHIFT → Press RESET/SHIFT → (114) (115) (116) Select an display factor by + and - (If a sub-monitor is selected, an under bar will be displayed on the bottom of a digital display.) → Press SET → Selected display factor is entered → Press DISPLAY → Returns to display mode.	26, 27

(3) Setting of frequency measurement range

Each parenthesized number shows a setting number and this number is displayed on the setting screen.

Items	Setting and operation procedures	Page
Setting of measurement range in frequency. (213)	Press SET and RESET/SHIFT together for longer than 3 seconds ➔ Press RESET/SHIFT (211) ➔ Press RESET/SHIFT ➔ Select a measuring range by + and - ➔ Press SET ➔ (212) (213) Selected measuring range is entered ➔ Press DISPLAY ➔ Returns to display mode.	32

(4) Setting of analog output.

Each parenthesized number shows a setting number and this number is displayed on the setting screen.

Items	Setting and operation procedures	Page
Setting of output cut function at the case in minute input (3-phase voltage is 0.5% or less, zero-phase voltage is 1.0% or less). (225A)	Press SET and RESET/SHIFT together for longer than 3 seconds ➔ Press MODE ➔ (211) (221A) Press RESET/SHIFT ➔ Press RESET/SHIFT ➔ Press RESET/SHIFT ➔ Press RESET/SHIFT (222A) (223A) (224A) ➔ Select a low Input cut ON/OFF by + and - ➔ Press SET ➔ (225A) Selected action is entered ➔ Press DISPLAY ➔ Returns to display mode.	33

(5) Setting of alarm output.

Each parenthesized number shows a setting number and this number is displayed on the setting screen.

Items	Setting and operation procedures	Page
Setting of return method in alarm output 1. (122AL)	Press SET for longer than 3 seconds ➔ Press MODE ➔ Press RESET/SHIFT ➔ (111) (121AL) (122AL) Select a return method by + and - ➔ Press SET ➔ Selected return method is entered ➔ Press DISPLAY ➔ Returns to display mode.	28
Setting of return method in alarm output 2. (125AL)	Press SET for longer than 3 seconds ➔ Press MODE ➔ Press RESET/SHIFT ➔ (111) (121AL) (122AL) Press RESET/SHIFT ➔ Press RESET/SHIFT ➔ Press RESET/SHIFT ➔ (123AL) (124AL) (125AL) Select a return method by + and - ➔ Press SET ➔ Selected return method is entered ➔ Press DISPLAY ➔ Returns to display mode.	28

(6) Setting of 3-phase voltage detection.

Each parenthesized number shows a setting number and this number is displayed on the setting screen.

Items	Setting and operation procedures	Page
Setting of high-alarm value in 3-phase voltage. (131H)	Press SET for longer than 3 seconds ➔ Press MODE ➔ Press MODE ➔ (111) (121AL) (131H) Select a high-alarm value by + and - ➔ Press SET ➔ Selected high-alarm value is entered ➔ Press DISPLAY ➔ Returns to display mode.	29
Setting of low-alarm value in 3-phase voltage. (132L)	Press SET for longer than 3 seconds ➔ Press MODE ➔ Press MODE ➔ (111) (121AL) (131H) Press RESET/SHIFT ➔ Select a low-alarm value by + and - ➔ Press SET ➔ (132L) Selected low-alarm value is entered ➔ Press DISPLAY ➔ Returns to display mode.	29
Setting of demand time interval in a line voltage. (133)	Press SET for longer than 3 seconds ➔ Press MODE ➔ Press MODE ➔ (111) (121AL) (131H) Press RESET/SHIFT ➔ Press RESET/SHIFT ➔ Select a time interval by + and - ➔ (132L) (133) Press SET ➔ Selected time interval is entered ➔ Press DISPLAY ➔ Returns to display mode.	29

(7) Setting of zero-phase voltage detection.

Each parenthesized number shows a setting number and this number is displayed on the setting screen.

Items	Setting and operation procedures	Page
Setting of high-alarm value in zero-phase voltage. (141H)	Press SET for longer than 3 seconds → Press MODE → Press MODE → Press MODE (111) (121AL) (131H) → Select a high-alarm value by + and - → Press SET → (141H) Selected high-alarm value is entered → Press DISPLAY → Returns to display mode	30
Setting of measurement response time in zero-phase voltage. (142)	Press SET for longer than 3 seconds → Press MODE → Press MODE → Press MODE (111) (121AL) (131H) → Press RESET/SHIFT → Select a response time by + and - → Press SET → (141H) (142) Selected response time is entered → Press DISPLAY → Returns to display mode.	30
Setting of automatic change ON/OFF to ground fault phase detection display. (143)	Press SET for longer than 3 seconds → Press MODE → Press MODE → Press MODE (111) (121AL) (131H) → Press RESET/SHIFT → Press RESET/SHIFT → Select a function by + and - → (141H) (142) (143) Press SET → Selected function is entered → Press DISPLAY → Returns to display mode	30

(8) Backlight setting

Each parenthesized number shows a setting number and this number is displayed on the setting screen.

Items	Setting and operation procedures	Page
Setting of action in backlight. (151)	Press SET for longer than 3 seconds → Press MODE → Press MODE → Press MODE (111) (121AL) (131H) → Press MODE → Select a backlight action by + and - → Press SET → (141H) (151) Selected backlight action is entered → Press DISPLAY → Returns to display mode.	31
Setting of brightness in backlight. (152)	Press SET for longer than 3 seconds → Press MODE → Press MODE → Press MODE (111) (121AL) (131H) → Press MODE → Press RESET/SHIFT → Select a brightness by + and - → (141H) (151) (152) Press SET → Selected backlight brightness is entered → Press DISPLAY → Returns to display mode.	31

(9) Other, measurement setting

Each parenthesized number shows a setting number and this number is displayed on the setting screen.

Items	Setting and operation procedures	Page
Setting of dead band in measurement display. (321)	Press SET and RESET/SHIFT together for longer than 3 seconds → Press MODE → (311) (321) Select a dead band value of measurement by + and - → Press SET → The dead band value of display is entered → Press DISPLAY → Returns to display mode	37

5.3 Setting in detail explanation

5.3.1 Setting mode 1

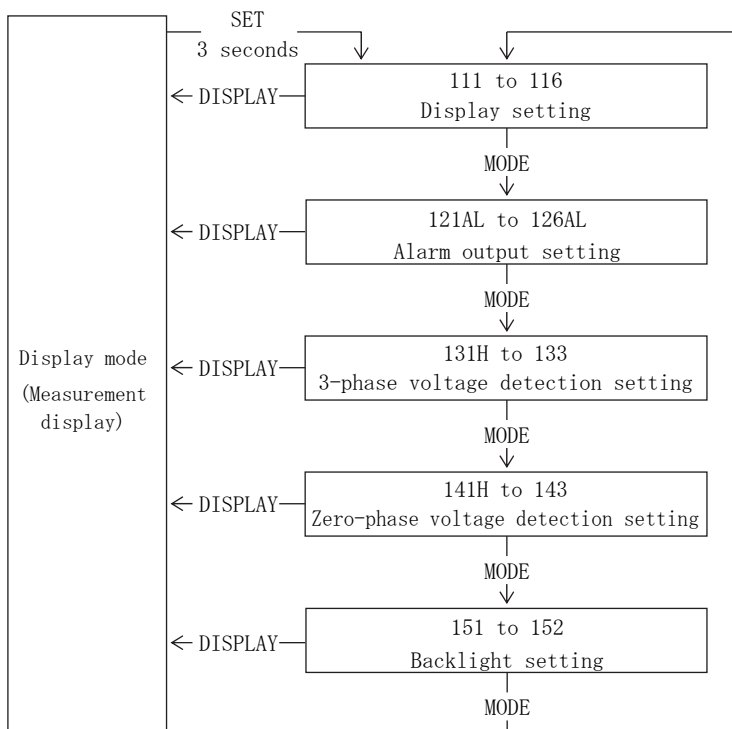

Setting mode 1 is selected by pressing **SET** switch for longer than 3 seconds. Pushing **MODE** switch performs movement of setting item. The present mode can be returned to the display mode by pressing **DISPLAY** switch.

< Caution >
If setting change should have been mistaken, an alarm output is not obtained correctly. Therefore, users must not set. The setting item without the corresponding option is not displayed.

Setting mode 1

(1) 111 to 116 Display combination setting

No.	Pattern No.	Main monitor	Sub-monitor (Left)	Sub-monitor (Center)	Sub-monitor (Right)	Bar graph
1	Pattern 1	MVo	V(RS)	V(ST)	V(TR)	MVo+Vo
2	Pattern 2	MVo	V(RN)	V(SN)	V(TN)	MVo+Vo
3	Pattern 3	V(RS)	V(ST)	V(TR)	Hz	V(RS)
4	Pattern 4	MVo	V(RS)	—	Hz	V(RS)
5	Pattern 5	Vo	V(RS)	V(ST)	V(TR)	MVo+Vo
6	Pattern 6	Vo	V(RN)	V(SN)	V(TN)	MVo+Vo
7	Pattern 7	Vo	V(RS)	—	Hz	V(RS)

● Displays set factor ⁽¹⁴⁾

Displays factor	Measurement factor
Main monitor	Voltage (VRS, VST, VTR, VRN, VSN, VTN), Maximum zero-phase voltage (MVo), Zero-phase voltage (Vo), Frequency (Hz)
Sub-monitor (Left)	Voltage (VRS, VST, VTR, VRN, VSN, VTN)
Sub-monitor (Center)	Voltage (VRS, VST, VTR, VRN, VSN, VTN)
Sub-monitor (Right)	Voltage (VRS, VST, VTR, VRN, VSN, VTN), Frequency (Hz)
Bar graph	Voltage (VRS, VST, VTR, VRN, VSN, VTN), Maximum zero-phase voltage (MVo), Zero-phase voltage (Vo), Frequency (Hz)

● Phase (line) change ⁽¹⁵⁾

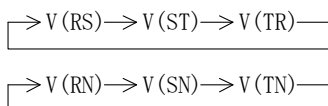

● Measurement factor change (Measurement display mode) ⁽¹⁴⁾

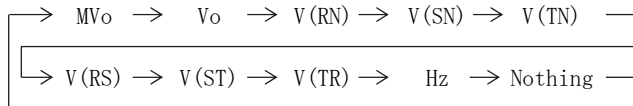

Note⁽¹⁴⁾ V(RN), V(SN), V(TN) becomes only phase voltage input products.

Note⁽¹⁵⁾ If **DISPLAY** is pushed, a phase voltage and a line voltage will change.

● Display combination setting

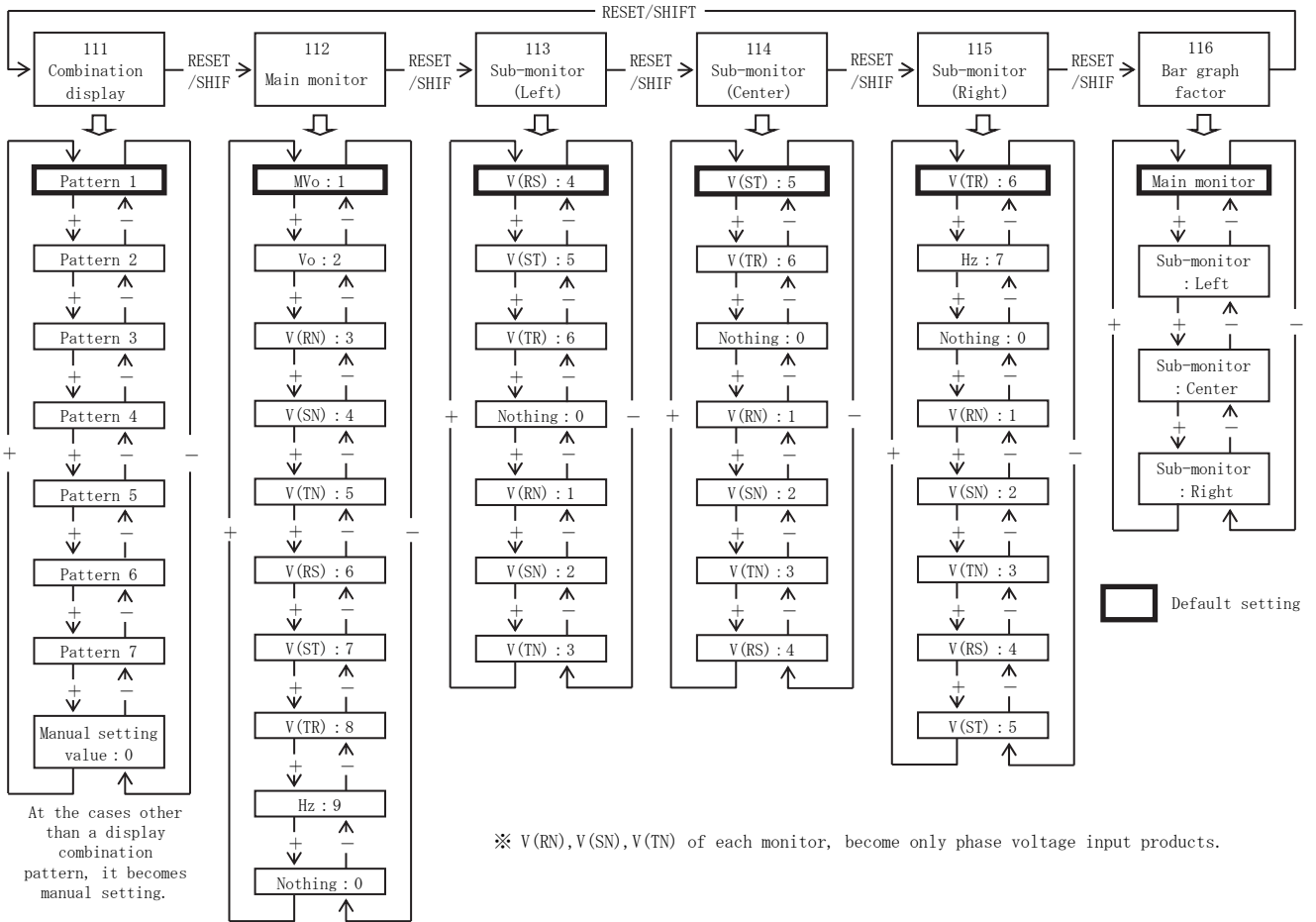

- ◆ 111 Combination display
Select the factors to be measured and monitored by 4 digital displays out of combination patterns. Set values are updated by **SET**.
- ◆ 112 to 115 Main monitor, Sub-monitor (left), Sub-monitor (center), Sub-monitor (right)
Set these items for a display configuration other than combined patterns. Set values are updated by **SET**.
- ◆ 116 Bar graph factor
A factor being monitored in the main monitor is basically displayed by a bar graph. Set this item for displaying a factor being monitored on a sub-monitor by bar graph. An under bar is attached to the digital display of the setting sub-monitor. Set values are updated by **SET**.

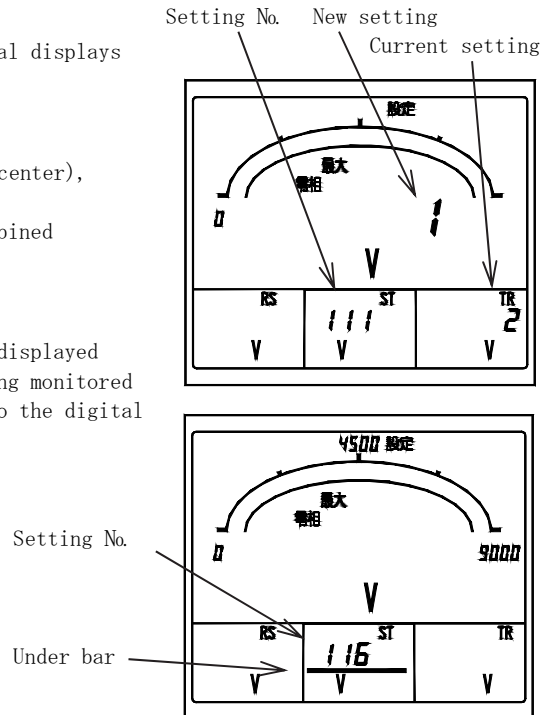

(2) 121AL to 126AL Alarm output setting 【With an alarm output option】

Various setting and an output test are performed about an alarm output. And, it sets about the corresponding alarm output.

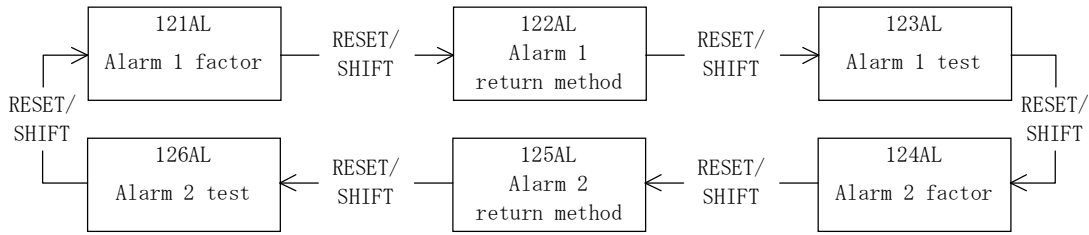

◆ 121AL Alarm 1 factor setting, 124AL Alarm 2 factor setting.

The output factor of alarms 1 and 2 is setting. Selection by **+** and **-**, set value is updated by **SET**.

Initial set value : ALARM 1 (Zero-phase voltage)
ALARM 2 OFF (Nothing)

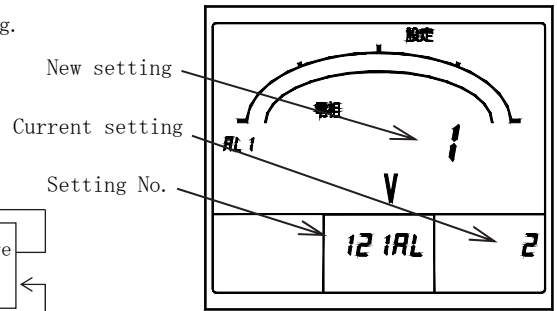
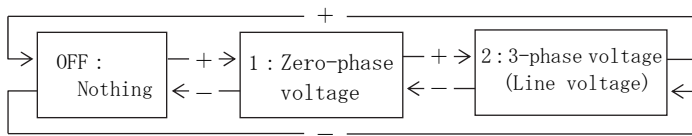

◆ 122AL Alarm 1 reset method setting, 125AL Alarm 2 reset method setting

Output action at the case of a reset of alarms 1 and 2 can be selected from AUTO (automatic reset) and HOLD (manual reset).

In "AUTO (automatic reset)", an alarm output also constitutes OFF according to a reset of an alarm.

In "HOLD (manual reset)", even after an alarm reset, an output holds ON. The reset in this case (output OFF) is performed in **RESET/SHIFT**.

Selection by **+** and **-**, set value is updated by **SET**.

Default setting : AUTO <自動復帰> (Automatic reset)

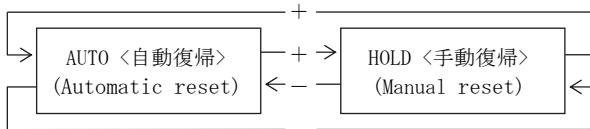

◆ 123AL Alarm 1 test, 126AL Alarm 2 test

The output of alarms 1 and 2 is tested. While pushing **SET**, an output is ON, and if it detaches, an output switches OFF. About a reset of an alarm, it becomes action united with reset method setting (automatic reset / manual reset) of each alarm output.

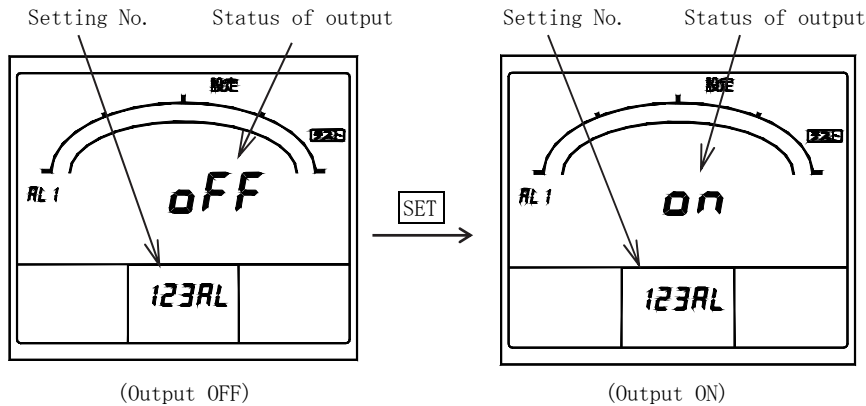

Alarm 1 test

(3) 131H to 133 3-phase voltage detection setting

3-phase voltage factor performs a setting of high-alarm value and low-alarm value.

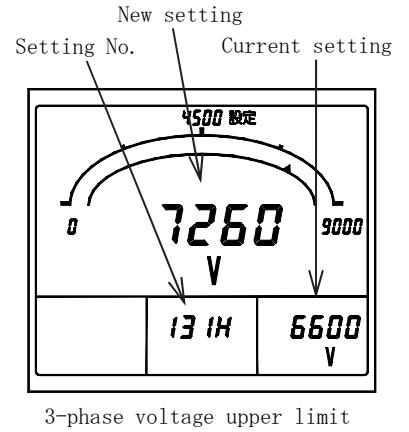
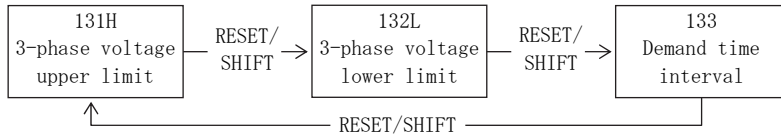

- ◆ 131H 3-phase voltage upper limit, 132L 3-phase voltage lower limit
The high-alarm value and low-alarm value of 3-phase voltage (line voltage) are setting.

Setting range. 30 to 150% (1% step) and OFF (Non use).
Selection by and , set value is updated by .

Default setting : OFF [Non use] (Upper limit, Lower limit)

- ◆ 133 Demand time interval

The demand time interval of a line voltage is setting.

Selection by and , set value is updated by .

Default setting : 0 second

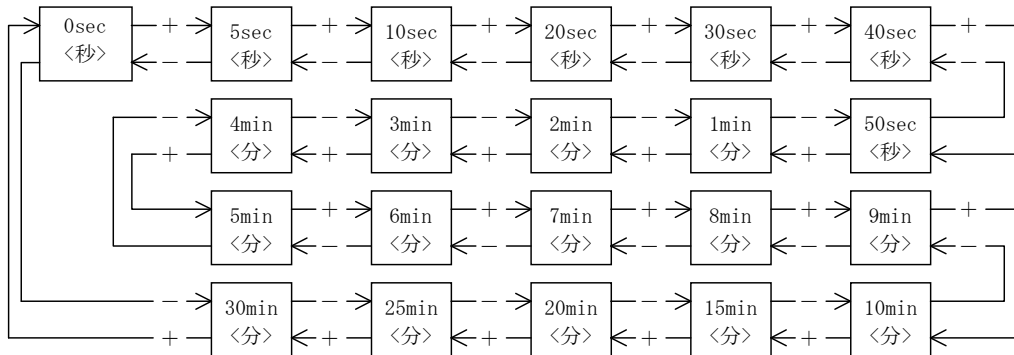

(4) 141H to 143 Zero-phase voltage detection setting

Setting of the alarm value of a zero-phase voltage factor, the response time, and a display change is performed.

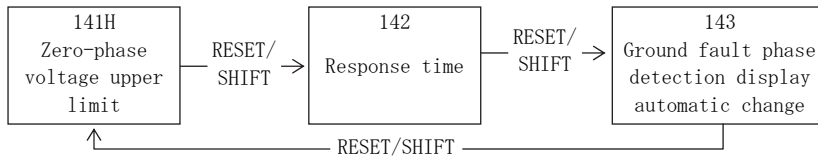

◆ 141H Zero-phase voltage upper limit

The upper limit of zero-phase voltage is setting.
 Setting range. 5 to 150% (1% step) and OFF (Non use).
 Selection by **+** and **-**, set value is updated by **SET**.
Default setting : 5280V

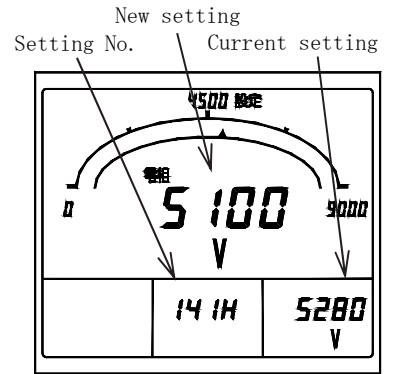

Zero-phase voltage upper limit

◆ 142 Response time

The response time (90% response) of zero-phase voltage is setting.
 Selection by **+** and **-**, set value is updated by **SET**.
Default setting : 0.1 seconds <秒>

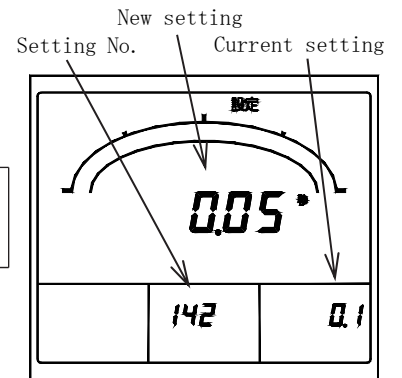
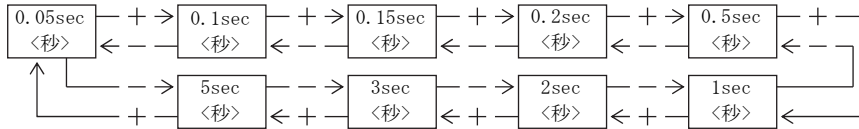

Response time

◆ 143 Ground fault phase detection display automatic change

Set the whether it changes from a measurement display (an instantaneous measurement display, the maximum, and the minimum measurement display) to a ground fault phase detection display automatically at the case of ground fault phase occurrence.
 Selection by **+** and **-**, set value is updated by **SET**.
Default setting : OFF (Not change)

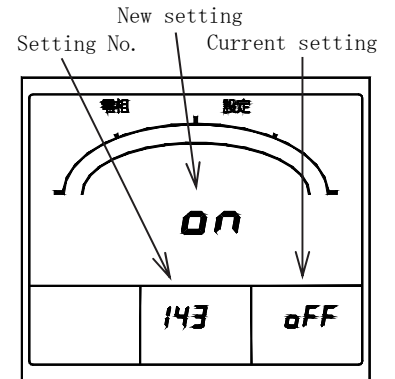

Zero-phase voltage upper limit

<Caution> In addition to this setting, the display can be switched to the ground fault detection display by a switch operation. Please refer to "4.3.3 Ground fault phase detection display change" about switch operation.

- (5) 151 to 152 Backlight setting
Set the action and brightness of backlight.

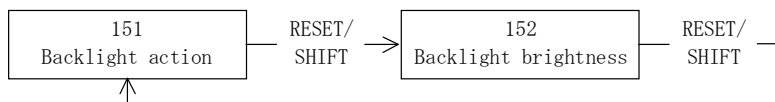

◆ 151 Backlight action

The backlight operation can be selected from ON (always on), AUTO (auto off), and OFF (always off).
If 5 minutes elapses without operating a switch in case it is set as "AUTO (auto off)", backlight will go out automatically.
After that, backlight will be turned on if either of switches is operated.
Selection by and , set value is updated by .

Default setting : AUTO (Auto off)

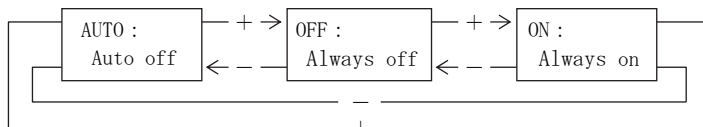

◆ 152 Backlight brightness

The backlight brightness can be selected in 5 levels.
Backlight becomes the darkest if it is set as "1".
Backlight becomes the brightest if it is set as "5".
Selection by and , set value is updated by .

Default setting : 3 (Middle)

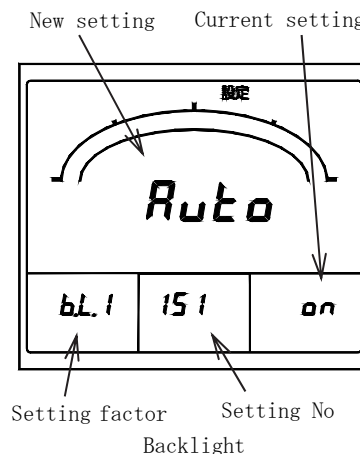

Setting	Brightness
5	Bright
4	↕
3	
2	
1	Dark

5.3.2 Setting mode 2

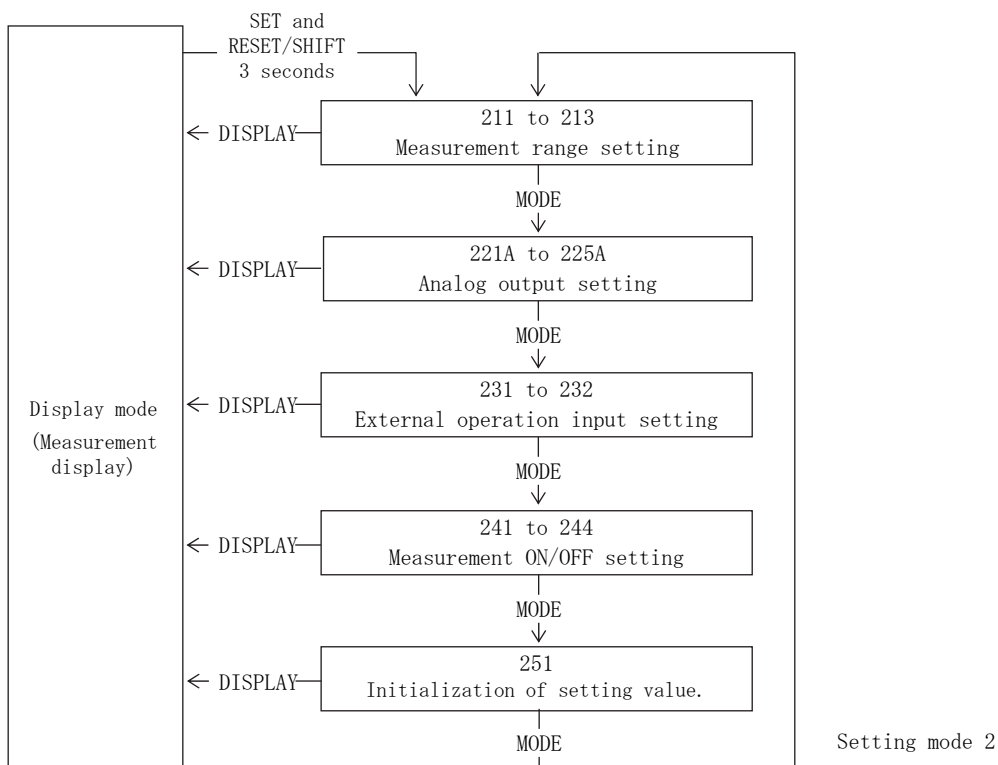

Setting mode 2 is selected by pressing and switches continuously for longer than 3 seconds. Pushing switch performs movement of setting item. The present mode can be returned to the display mode by pressing switch.

< Caution >

If setting change should have been mistaken, a display and output of measurement are not obtained correctly. Therefore, users must not set. The setting item without the corresponding option is not displayed.

(1) 211 to 213 Measurement range setting

The measurement range of each measurement factor is set.

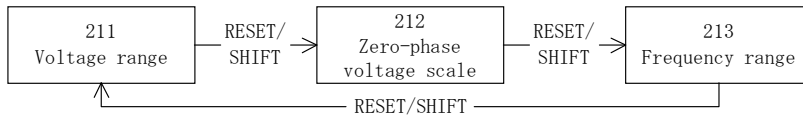

◆ 211 Voltage range

A voltage range (VT ratio) is setting.

Selection by and , set value is updated by .

Default setting : 6600V

Voltage measurement range (34 range)

150.0V (110V)	15.00kV (11kV/110V)
150V (110V)	18.00kV (13.2kV/110V)
300.0V (220V/110V)	18.82kV (13.8kV/110V) ⁽¹⁹⁾
300V (220V/110V)	22.50kV (16.5kV/110V) ⁽²⁰⁾
518V (380V/110V) ⁽¹⁶⁾	25.09kV (18.4kV/110V) ⁽²¹⁾
600V (440V/110V)	30.0kV (22kV/110V)
627V (460V/110V) ⁽¹⁷⁾	45.0kV (33kV/110V)
655V (480V/110V) ⁽¹⁷⁾	90.0kV (66kV/110V)
1200V (880V/110V)	105.0kV (77kV/110V) ⁽²²⁾
1500V (1100V/110V)	150.0kV (110kV/110V)
2250V (1650V/110V) ⁽¹⁸⁾	180.0kV (132kV/110V)
3000V (2200V/110V)	210.0kV (154kV/110V)
3.00kV (2200V/110V)	255.0kV (187kV/110V) ⁽²³⁾
4500V (3300V/110V)	300.0kV (220kV/110V)
4.50kV (3300V/110V)	375.0kV (275kV/110V) ⁽²⁴⁾
9000V (6600V/110V)	518.2kV (380kV/110V) ⁽²⁵⁾
9.00kV (6600V/110V)	750.0kV (550kV/110V)

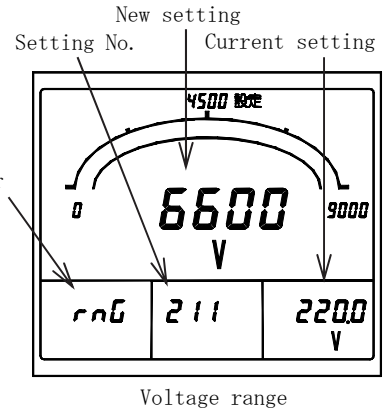

- Note⁽¹⁶⁾ The full scale of bar graph is 500V.
- Note⁽¹⁷⁾ The full scale of bar graph is 600V.
- Note⁽¹⁸⁾ The full scale of bar graph is 2400V.
- Note⁽¹⁹⁾ The full scale of bar graph is 18.00kV.
- Note⁽²⁰⁾ The full scale of bar graph is 24.00kV.
- Note⁽²¹⁾ The full scale of bar graph is 25.00kV.
- Note⁽²²⁾ The full scale of bar graph is 120.0kV.
- Note⁽²³⁾ The full scale of bar graph is 270.0kV.
- Note⁽²⁴⁾ The full scale of bar graph is 400.0kV.
- Note⁽²⁵⁾ The full scale of bar graph is 500.0kV.

◆ 212 Zero-phase voltage scale

Display ON/OFF of $\times 1/\sqrt{3}$ is set as a scale of zero-phase voltage.

Selection by and , set value is updated by .

Default setting : $\times 1/\sqrt{3}$ display OFF

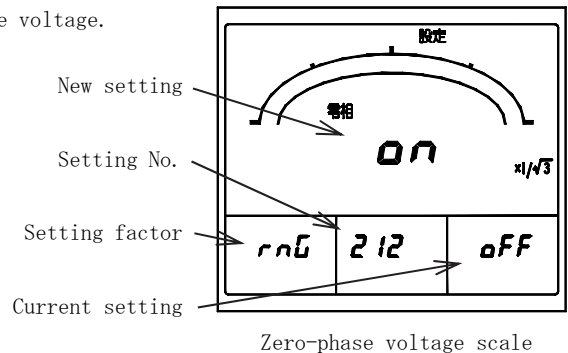
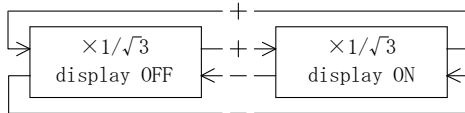

Zero-phase voltage scale

◆ 213 Frequency range

Frequency measurement range can be selected from 45.0 to 55.0Hz / 55.0 to 65.0Hz / 45.0 to 65.0Hz. Change of this setting also sets the analog output range of a frequency automatically simultaneously.

Selection by and , set value is updated by .

Default setting : 45.0 to 65.0Hz

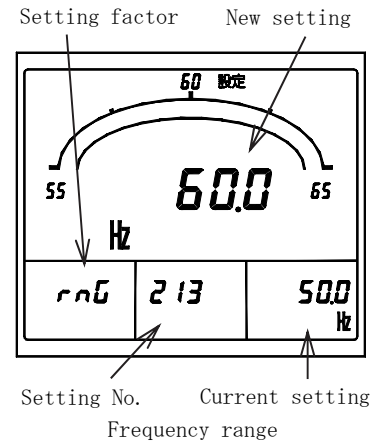
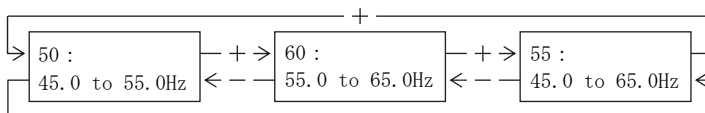

Frequency range

(2) 221A to 225A Analog output setting **【With an analog output option】**
 Various setting of analog output is performed.

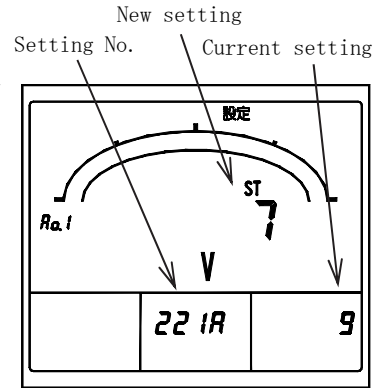
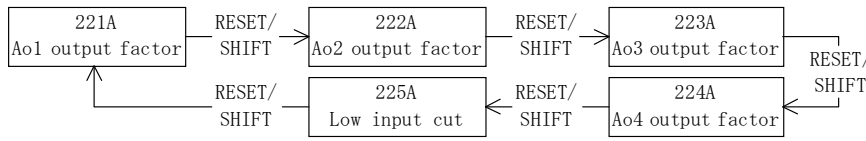

Ao1 output factor

- ◆ 221A to 224A AO(analog output)1 to 4 output factor.
 Set the output factor of each analog outputs.
 Selection by **[+]** and **[-]**, set value is updated by **[SET]**.
 V(RS), V(ST), V(TR) becomes only phase voltage input product.

Default setting : AO1 MVo
AO2 V(RS)
AO3 V(ST)
AO4 V(TR)

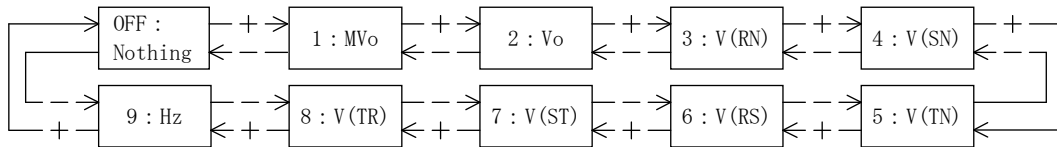

- ◆ 225A Low input cut
 This function which makes analog output a lower limit at the case of a minute input. A function can be selected from ON (Use) and OFF (Non use). However, in case an output is frequency, a low input cut is not done.
 Selection by **[+]** and **[-]**, set value is updated by **[SET]**.
Default setting : OFF (Non use)

Cut value
 Zero-phase voltage : Full scale 1.0% or less.
 Voltage : Full scale 0.5% or less.

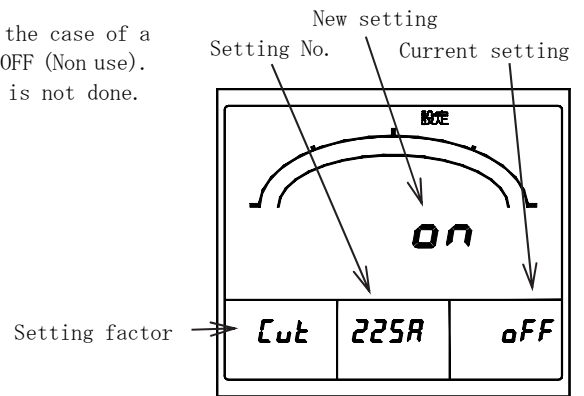

Low input cut

(3) 231 to 232 External operation input setting 【With an external operation input option】
 Various setting of external operation input is performed.

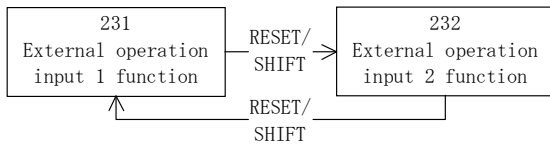

- ◆ 231 External operation input 1 function,
- 232 External operation input 2 function

The function of each external operation input (alarm reset, maximum / minimum reset, measurement factor change, phase change) can be selected.

Selection by and , set value is updated by .

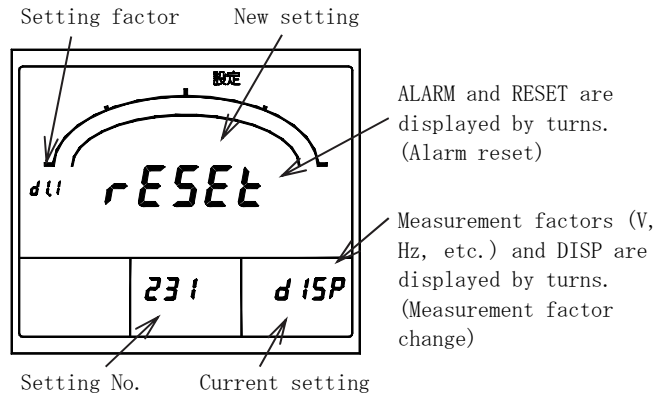

Default setting (With an alarm output option)

- Alarm reset (External operation input 1)
- Maximum / minimum reset (External operation input 2)

Default setting (With no alarm output option)

- Maximum / minimum reset (External operation input 1)
- Measurement factor change (External operation input 2)

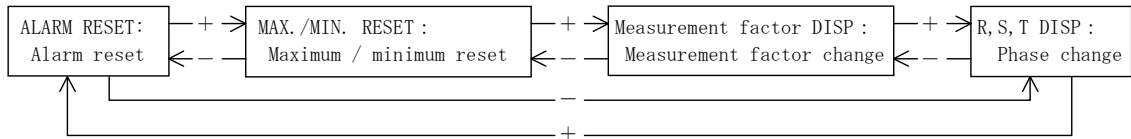

• About the setting display in an external operation input function

Function	The contents of a display at the case of function setting	"Current setting" display point	"New setting" display point
Alarm reset	"ALARM" and "RESET" are displayed by turns by 7 segment displays of the main monitor.	Sub-monitor (right)	Main monitor
Maximum / Minimum reset	"RESET" is displayed by 7 segment displays of the main monitor. And, "MAX <最大>" and "MIN <最小>" display by turns.		
Measurement factor change	"DISP" is displayed by 7 segment displays of the main monitor. And, each measurement factor (units of V, Hz, etc.) displays by turns.		
Phase change	"DISP" is displayed by 7 segment displays of the main monitor. And, each phase (R, S, T, N) displays by turns.		

(4) 241 to 244 Measurement ON/OFF setting 【Phase voltage is only for phase voltage input product】

Measurement display ON/OFF setting of each measurement factor is performed.
 Selection by **[+]** and **[-]**, set value is updated by **[SET]**.
 Default setting: ON (All measurement factors)

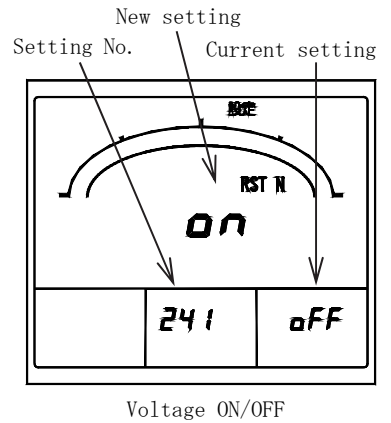
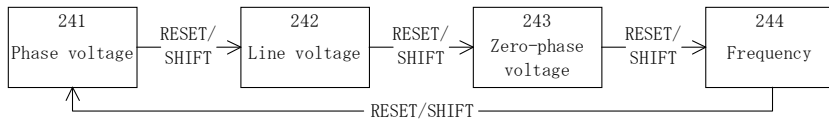

(5) 251 Initialization of setting value

Each set value is initialized (returns to default setting)

◆ 251 Initialization of setting value

Each set value is initialized (returns to default setting).
 Pushing **[SET]** for 3 seconds initializes all set values.

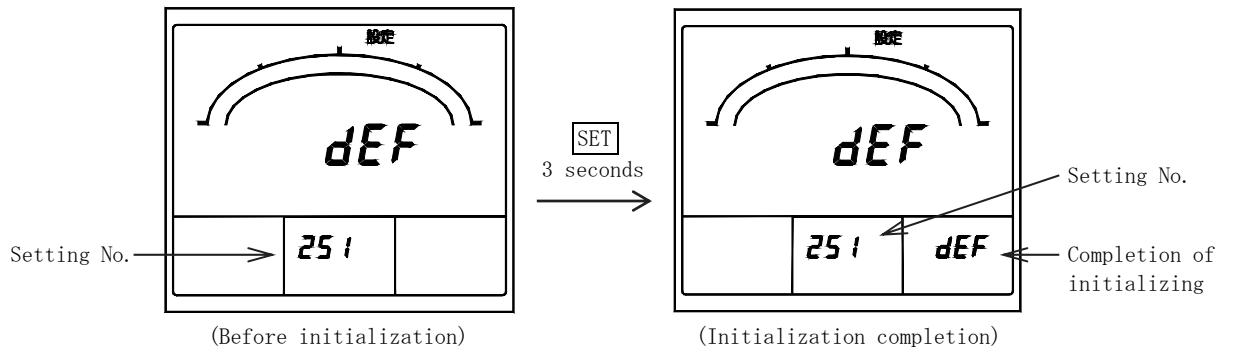

5.3.3 Setting mode 3

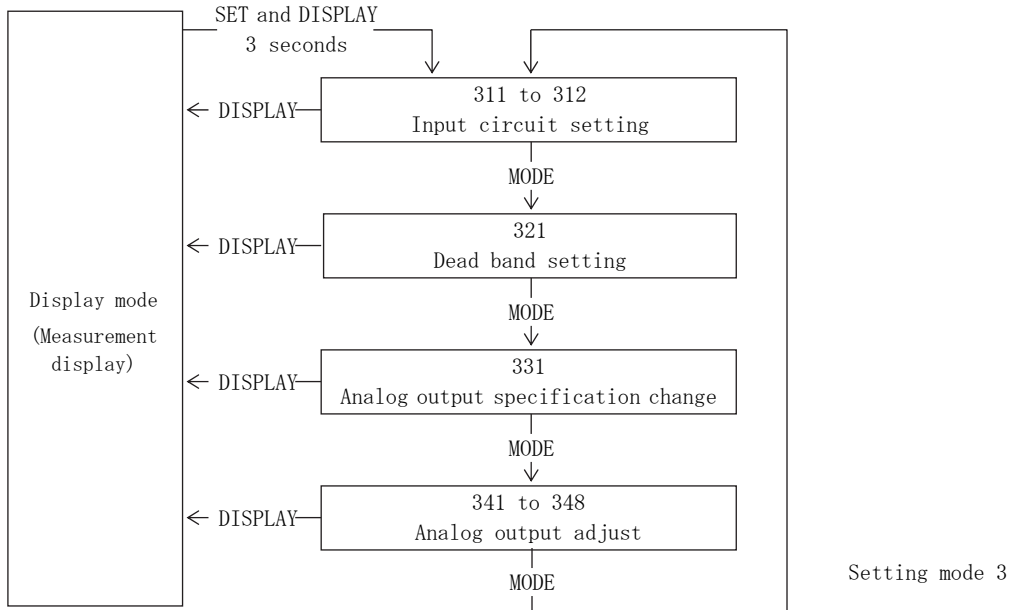

Setting mode 3 is selected by pressing **SET** and **DISPLAY** switches continuously for longer than 3 seconds. Pushing **MODE** switch performs movement of setting item. The present mode can be returned to the display mode by pressing **DISPLAY** switch.

< Caution >

If setting change should have been mistaken, a display and output of measurement are not obtained correctly. Therefore, users must not set. The setting item without the corresponding option is not displayed.

(1) 311 to 312 Input circuit setting

Set the about the input voltage of zero-phase input, and rated frequency.

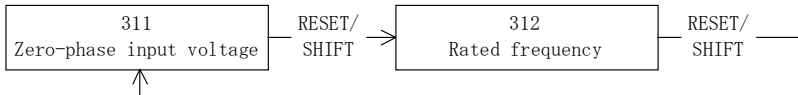

◆ 311 Zero-phase input voltage

Set the about a zero-phase input voltage.

Selection by **+** and **-**, set value is updated by **SET**.

Default setting : 190V

<Caution>

If an actual input and an actual setup differ from each other, it becomes impossible to measure correctly. Please set correctly.

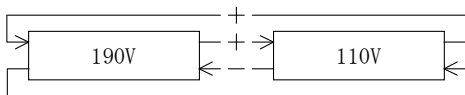

Setting No.

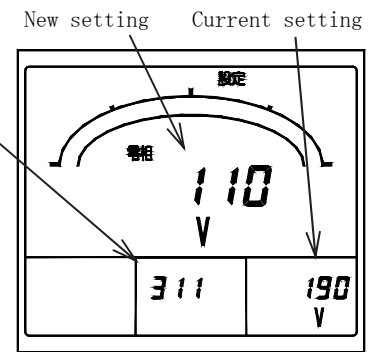

Zero-phase input voltage

◆ 312 Rated frequency

The frequency of a zero-phase input is setting.

Selection by **+** and **-**, set value is updated by **SET**.

Default setting : 50Hz

<Caution>

If an actual input and an actual setup differ from each other, it becomes impossible to measure correctly. Please set correctly.

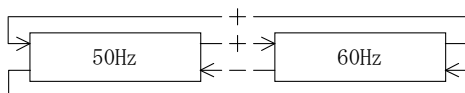

Setting No.

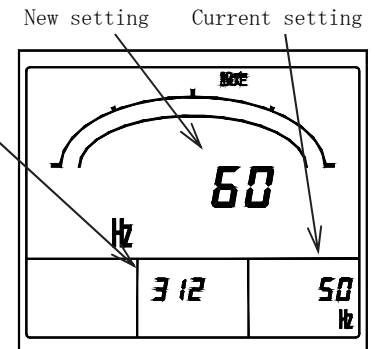

Rated frequency

- (2) 321 Dead band setting
Set the dead band of measurement display.

◆ 321 Measurement dead band
Set the dead band of measurement display.
By this setting, variation of less than this set value is disregarded by 3-phase voltage, and zero-phase voltage measurement display.
Setting range: 0.0 to 2.0% (0.1% step).
Selection by $\boxed{+}$ and $\boxed{-}$, set value is updated by \boxed{SET} .
Default setting: 0.0% (Nothing)

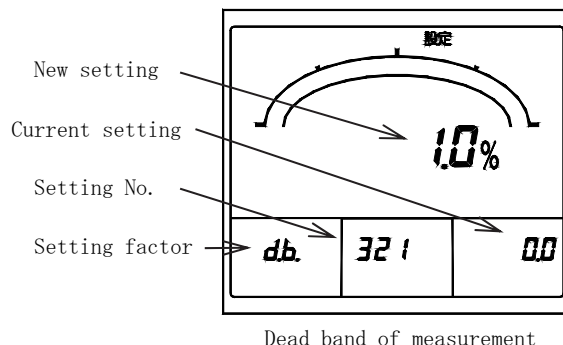

- (3) 331 Analog output specification setting 【With an analog output option (DC0 to 5V or DC1 to 5V)】
Set the specification of analog output (DC0 to 5V/DC1 to 5V).
Selection by $\boxed{+}$ and $\boxed{-}$, set value is updated by \boxed{SET} .
Default setting: DC1 to 5V or DC0 to 5V (Designation)

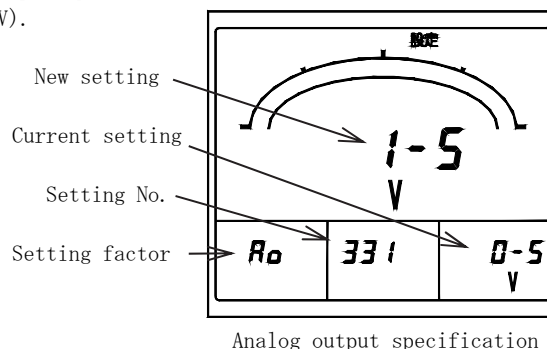
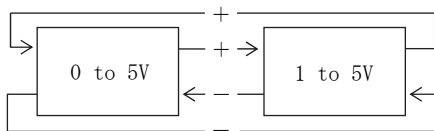

- (4) 341 to 348 Analog output adjustment 【With an analog output option】
The bias and span of each analog output are adjusted.

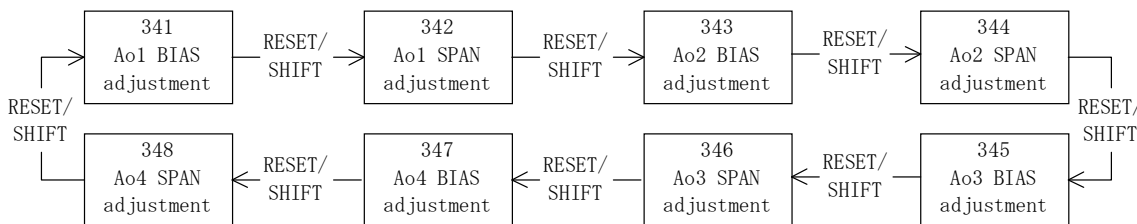

◆ 341 AO (Analog output) 1 bias adjustment,
343 AO (Analog output) 2 bias adjustment,
345 AO (Analog output) 3 bias adjustment,
347 AO (Analog output) 4 bias adjustment.
The bias of each analog output is adjusted.
Setting range: $\pm 10.0\%$ (0.1% step)
Selection by $\boxed{+}$ and $\boxed{-}$, set value is updated by \boxed{SET} .

◆ 342 AO (Analog output) 1 span adjustment,
344 AO (Analog output) 2 span adjustment,
346 AO (Analog output) 3 span adjustment,
348 AO (Analog output) 4 span adjustment.
The span of each analog output is adjusted.
Setting range: $\pm 10.0\%$ (0.1% step)
Selection by $\boxed{+}$ and $\boxed{-}$, set value is updated by \boxed{SET} .

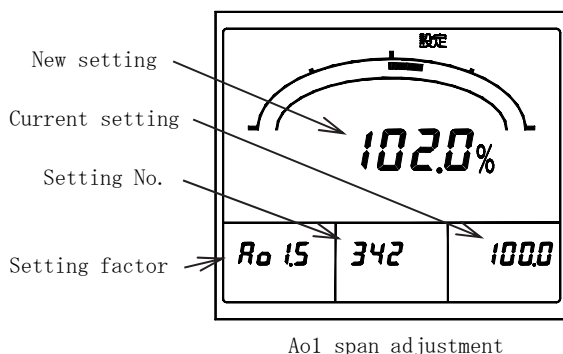

6. Specification

6.1 Specification and intrinsic error

Input rating	Phase voltage input	Zero-phase voltage (EVT tertiary) AC110V, 190V common use 3-phase voltage (EVT secondary) AC110/ $\sqrt{3}$ V 50/60Hz EVT secondary : V(RN), V(SN), V(TN) EVT tertiary : Vaf
	Line voltage input	Zero-phase voltage (EVT tertiary) AC110V, 190V common use 3-phase voltage (EVT secondary) AC110V 50/60Hz EVT secondary : V(RS), V(ST), V(TR) EVT tertiary : Vaf

Measurement item	Measurement range / Display specification ⁽²⁶⁾	Intrinsic error ⁽²⁷⁾		Note
		Digital display	Analog output	
Voltage (Line voltage)	Instant or demand, Maximum, Minimum AC150V to 750.0kV (34 ranges)	$\pm 1.0\%$	$\pm 0.5\%$	RS-ST-TR line change
				For demand time interval setting 0 second : Instantaneous measurement
				For other settings : Demand measurement
Voltage (Phase voltage) ⁽²⁸⁾	Instant, Maximum, Minimum AC150V to 750.0kV (34 ranges)	$\pm 1.0\%$	$\pm 0.5\%$	RN-SN-TN line change
				Ground fault phase is displayed from a RN-SN-TN phase voltage at the case of zero-phase voltage detection. ⁽³⁰⁾
				Response time setting is possible.
Zero-phase voltage ⁽²⁹⁾	Instant, Maximum, Minimum AC150V to 750.0kV (34 ranges)	$\pm 1.0\%$	$\pm 0.5\%$	Response time setting is possible.
Frequency	Instant, Maximum, Minimum 45.0 to 55.0Hz or 55.0 to 65.0Hz or 45.0 to 65.0Hz (Range select)	$\pm 0.5\%$	$\pm 0.5\%$	0.0Hz in case input is below 20% of voltage range.
Operating system	Voltage : Effective value computing type. Demand voltmeter (Line voltage) : Computing type according with bimetallic type. Zero-phase voltage, Ground fault phase detection : Fundamental-wave effective-value computing type Frequency : Zero cross cycle computing type.			
Response time setting	Maximum zero-phase voltage Ground fault phase detection	0.05 seconds / 0.1 seconds / 0.15 seconds / 0.2 seconds / 0.5 seconds / 1 second / 2 seconds / 3 seconds / 5 seconds (90% response)		
Demand time interval setting	Voltage	0 second / 5 seconds / 10 seconds / 20 seconds / 30 seconds / 40 seconds / 50 seconds / 1 minute / 2 minutes / 3 minutes / 4 minutes / 5 minutes / 6 minutes / 7 minutes / 8 minutes / 9 minutes / 10 minutes / 15 minutes / 20 minutes / 25 minutes / 30 minutes (95% time limit)		
Bar graph display	Bar graph display of the main-monitor factor is done. A display of a sub-monitor factor can also be set.			
Option	Analog output (4 sets), Alarm output (2 sets), External operation change input (2 sets)			

Note⁽²⁶⁾ The instantaneous value of each measurement factor can be checked by instantaneous measurement display. And, about the maximum value and the minimum value, it can check by the maximum and the minimum measurement display.

However, about a maximum zero-phase voltage, it can check by instantaneous measurement display.

Note⁽²⁷⁾ When the inverter output is directly measured in cycle control, SCR phase angle control, or PWM control, an error increases due to the operation principle.

Note⁽²⁸⁾ The line voltage input product is display OFF.

Note⁽²⁹⁾ When you measure zero-phase voltage, please be sure to perform connection of 3-phase voltage. In measurement of only a zero-phase voltage, an error becomes large.

Note⁽³⁰⁾ A ground fault phase constitutes the minimum phase of RN-SN-TN phase voltage. However, if a high order circuit breaker is OFF at the case of zero-phase voltage detection, all the minimum value of RN-SN-TN will be set to 0V. In that case, please check a ground fault phase at the maximum value of RN-SN-TN phase voltage.

● Measurable range

Measurement factor	Input	Measurable range	
		Display	Analog output
Voltage	AC0 to 150/ $\sqrt{3}$ V (Phase voltage input specification) AC0 to 150V (Line voltage input specification)	101% of meter full scale	101% of output span
Zero-phase voltage	AC0 to 150V (AC0 to 110V) AC0 to 259V (AC0 to 190V)	101% of meter full scale	101% of output span
Frequency	45.0 to 55.0Hz	44.9 to 55.1Hz	-1%, 101% of output span
	55.0 to 65.0Hz	54.9 to 65.1Hz	
	45.0 to 65.0Hz	44.8 to 65.2Hz	

6.2 Performance

Item	Specification		
Intrinsic error	Reference to measure specification and intrinsic error.		
Intrinsic error of bar graph	$\pm 10\%$ (% for span)		
Influence by temperature	23 \pm 10°C within intrinsic error.		
Conformity technical standard	JIS C 1102-1, -2, -4, -7 : 1997 , JIS C 1111 : 1989		
Display updating time	About 1 second (Bar graph : 0.25 seconds)		
Display device / Display composition	LCD	Main monitor	5 digit, character height 11mm
		Sub-monitor (Left)	4 digit, character height 6mm
		Sub-monitor (Center), (Right)	5 digit, character height 6mm
		Bar graph	20 dots
LCD view angle	Upper view angle and lower view angle 75° , Right and left view angle 75°		
Backlight	LED backlight : White ⁽³¹⁾ Always on, Auto off (after 5 minutes without operating), Always off. Setting is possible. Backlight can select brightness from five steps of 1 to 5.		
Auxiliary supply	(1) AC85 to 264V 50/60Hz 10VA (Rated voltage, AC100/110V, 200/220V) DC80 to 143V 6W (Rated voltage, DC100/110V) for both AC and DC uses		
	(2) DC20 to 56V 6W (Rated voltage, DC24/48V)		
Rush current (Time constant)	Rated voltage AC110V 2.2A or less (About 3.6ms)		
	Rated voltage AC220V 4.4A or less (About 3.6ms)		
	Rated voltage DC110V 1.6A or less (About 3.6ms)		
	Rated voltage DC24V 5.0A or less (About 2.0ms)		
	Rated voltage DC48V 9.9A or less (About 2.0ms)		
Input consumption VA	Voltage circuit	0.05VA or less (110/ $\sqrt{3}$ V) , 0.1VA or less (110V)	
	Zero-phase voltage circuit	0 to 5VA or less (190V)	
Overload capacity	Voltage circuit	2 times 10 seconds, 1.2 times continuation of rated voltage.	
	Auxiliary supply	1.5 times 10 seconds, 1.2 times continuation of rated voltage. In case of DC110V, 1.5 times 10 seconds, 1.3 times continuation of rated voltage.	
Insulation resistance JIS C 1102-1 JIS C 1111	Between electric circuits and case (ground).		
	Between input and output and auxiliary supply.		
	Between AC inputs (3-phase voltage and zero-phase voltage).		
	Between outputs (analog output and alarm output).		
	Between alarm outputs.		
Between analog outputs are not insulation of minus common.			
Withstand voltage JIS C 1102-1 JIS C 1111	Between electric circuits and case (ground).		
	Between input and output and auxiliary supply.		
	Between AC inputs (3-phase voltage and zero-phase voltage).		
	Between outputs (analog output and alarm output).		
	Between alarm outputs.		
Between analog outputs are not insulation of minus common.			
Impulse withstand voltage JIS C 1111	Between electric circuits (An analog output is excluded) and case (ground).		
	Between analog output and case (ground).		
		5kV 1.2/50 μ s Both positive and negative polarities, for each 3 time.	

Note⁽³¹⁾ The white backlight of this product is using white LED which combined the special phosphor and blue LED. In the characteristics of this LED, color tone may be different for each product.

Item	Specification
Noise-capacity JEA B-402	<p>(1) Oscillatory surge voltage When a damping vibration waveform (peak voltage 2.5kV, frequency 1MHz±10%) is repeatedly applied, the measurement error should be within 10% and no malfunction should occur. Voltage input circuit (Normal / Common) Auxiliary supply circuit (Normal / Common)</p> <p>(2) Square wave impulse noise If a noise (1μs, 100ns width) is repeated and added, a measurement error should be within 10%. And, there needs to be no malfunction. Auxiliary supply circuit (Normal / Common) Over 1500V Voltage input circuit (Normal / Common) Over 1500V Alarm output (Common) Over 1000V Operation input (Common) Over 1000V Analog output circuit (Induction) Over 1000V</p> <p>(3) Electric wave noise If intermittence irradiation of the electric wave of a 150MHz, 400MHz band is done by (5W, 1m), a measurement error should be within 10%. And, there needs to be no malfunction.</p> <p>(4) Electrostatic noise Measurement error should be within 10% at contact discharge 8kV and air discharge 15kV, and malfunction shall not occur. And, do not be a communication error and stop.</p>
Vibration, Shock JIS C 1102-1	Vibration : Single amplitude 0.15mm, 10 to 55Hz, Each minute octave in 5 times sweep. Shock : 490m/s ² Each 3 times to the X, Y, Z direction.
Construction	Dimension : 110mm(Width)×110mm(Height)×103.5mm(Depth) Body diameter : 99mm φ With terminal cover
Ingress Protection code	IP40
Material	Case, Cover : ABS(V-0) , Terminal block : PBT , Terminal cover : Polycarbonate
Color	Black (Munsell N1.5)
Mass	Approx. 600g
Blackout guarantee	Maximum value, Minimum value, Ground fault phase detection display, Each setting value. Data hold by nonvolatile memory.
Operating temperature and humidity limits	-10 to +55°C , 30 to 85% RH, Non condensing.
Storage temperature limits	-25 to +70°C

6.3 Option

Item	Specification		
Analog output	Number of output	4 circuits	
	Output specification	DC4 to 20mA (Below 550Ω)	
		DC0 to 1mA (Below 10kΩ)	
		DC0 to 5V/1 to 5V (Over 600Ω)	
		DC0 to 10V (Over 2kΩ)	
		One of them is designated by identical ratings.	
	Output factor	Phase voltage (RN-SN-TN), Line voltage (RS-ST-TR), Frequency, Maximum zero-phase voltage, Zero-phase voltage A phase voltage (RN-SN-TN) constitutes only phase voltage input product.	
	Response time	Maximum zero-phase voltage, Zero-phase voltage, Voltage (RN-SN-TN) : Response time setting + 1 second or less. Voltage (RS-ST-TR), Frequency : 1 second or less (Time within ±1% of final constant value.)	
	Low input cut	An output is fixed to a lower limit if input is below a cut value. (Function ON / OFF is possible at a setting.) However, in the case of frequency, it excludes. Low input cut value. Zero-phase voltage : Full scale 1.0% or less. Voltage : Full scale 0.5% or less.	
	Output ripple	Within the double precision of accuracy (% for output span)	
Output adjustment	Bias and a span adjustment are possible according to each output individual.		
	Adjustable range	Bias	±10.0% (0.1% step) % for output span.
		Span	±10.0% (0.1% step) % for output span.
Between outputs are not insulation of minus common.			

Item	Specification		
Alarm output	Alarm factor : Zero-phase voltage, Line voltage (The maximum value between each line), Alarm OFF. Possible to setting one of them. (Alarm 2 circuit setting of each is possible.) Reset form : Automatic reset or Manual reset (Setting) Output contact : No voltage normally open contact (a contact) (OR of each phase detection) Contact capacity : AC250V 8A, DC125V 0.3A (Resistance load), AC250V 2A, DC125V 0.1A (Inductive load)		
	Alarm factor	Specification	
	Zero-phase voltage	Function	Measurement value \geq Upper limit setting value, Alarm display and alarm output. With a ground fault phase detection display automatic change function. (In case of detection.) (Setting of use / not use is possible for a ground fault phase detection display automatic change function.) Ground fault phase detection display : A maximum zero-phase voltage and the minimum phase voltage are displayed. A maximum zero-phase voltage and minimum phase voltage update after of zero-phase voltage detection. After backlight turns on, backlight is off when not operating it for 5 minutes. (At the case of setting in backlight automatic off.)
		Setting accuracy	$\pm 1.0\%$ (% to the value which set a full scale to 150%)
		Setting range	5 to 150% (1% step) or OFF (not use), Full scale=150%.
	Line voltage (The maximum value between each line)	Function	Measurement value \geq Upper limit setting value, Alarm display and alarm output. (Detects by the maximum phase) Measurement value \leq Lower limit setting value, Alarm display and alarm output. (Detects by the minimum phase)
		Setting accuracy	$\pm 1.0\%$ (% to the value which set a full scale to 150%)
		Setting range	30 to 150% (1% step) or OFF (not use), Full scale=150%.
	External operation input	Number of circuits	2 circuits, Function (4 types) is changed by setting.
		Function	4 types of following functions can be operated by adding a voltage signal from the outside in addition to switch operation.
Alarm reset		Alarm output is reset (output OFF). Please refer to "4.3.6 Reset" about operation by the switch.	
Maximum / Minimum reset		The maximum value / minimum value is reset (it updates to the instantaneous value at the time). Please refer to "4.3.6 Reset" about operation by the switch.	
Measurement factor change		The measurement display element of the main monitor is changed. Please refer to "4.3.1 Main monitor display-element change" about operation by the switch.	
Phase change		A phase/lines display of the voltage display is changed. Please refer to "4.3.2 Phase (between lines) display change" about operation by the switch.	
Minimum operation pulse width		300ms , Continuation applying is possible.	
Rated input	Input rating becomes the same as that of auxiliary supply. (1) AC100/110V 0.4VA, AC200/220V 1.4VA, DC100/110V 0.4W AC DC two ways. Contact capacity : About 3mA (AC, DC100/110V), About 6mA (AC200/220V) (2) DC24V 0.3W, DC48V 1.2W Contact capacity : About 10mA (DC24V) , About 20mA (DC48V)		

- Caution on the use of external display selection input (option)
External power consumption is 0.4VA at AC110V or 1.4VA at AC220V or 0.4W at DC110V.
In case a relay or a switch is used for power supply supply, please use the thing of about 1mA of the minimum application loads.

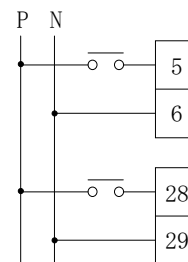

7. Maintenance and check

7.1 Trouble shooting

Symptoms	Possible causes	Remedial measures
Indicator does not display.	The power supply is not supplied. (Not connected. or voltage is low)	Check the auxiliary supply. Again, a power supply is supplied.
	Measurement display ON/OFF setting is set to OFF.	Setting check.
	Trouble of device.	Replace the device.
Measuring value error is noticeable	Range is not set correctly.	Please set again.
	Out of range in rated frequency (45.0 to 65.0Hz).	Cannot be used.
	Cycle control, SCR phase angle control, PWM control, or other inverter output is measured.	Cannot be used.
Analog output is not outputted.	Analog output is set to OFF or measurement factor is set to OFF.	Please check a setting
Alarm output does not return.	The return method is a "manual reset".	Please check a setting

7.2 Test

In case this product is tested, a special setting or operation is not needed fundamentally. However, the following test should operate it along with each process.

Alarm output test

Even if this product does not have input, it can perform ON/OFF test of an alarm output (relay contact output). Operation is performed by alarm 1 test and alarm 2 test in the setting mode 1.

Please refer to "5.3.1 Setting mode 1 (2) alarm output setup" about the details of operation.

In addition, an alarm return constitutes action corresponding to a return method setting (automatic reset / manual reset) of each alarm output.

< Operating process >

- Alarm 1 test (Setting No. 123)

Press **SET** for 3 seconds → Press **MODE** → Press **RESET/SHIFT** for 2 times → While pushing **SET**, the alarm 1 output is ON.

- Alarm 2 test (Setting No. 126)

Press **SET** for 3 seconds → Press **MODE** → Press **RESET/SHIFT** for 5 times → While pushing **SET**, the alarm 2 output is ON.

 DAIICHI ELECTRONICS CO., LTD.

Tokyo Office : 11-13, Hitotsuya 1-chome, Adachi-ku, Tokyo, 121-8639, JAPAN.
TEL : +81-3-3885-2411 , Fax : +81-3-3858-3966

Kyoto Office : 1-19, Ichinobe-Nishikawahara, Jyoyou-shi, Kyoto, 610-0114, JAPAN.
TEL : +81-774-55-1391 , Fax : +81-774-54-1353

Revision B, DATE : March 3, 2021