

INSTRUCTION MANUAL
(DETAILED VERSION)

OLED ALARM SETTER

SDEL-105

Contents

Overview	2
Safety precautions	2
Composition of type	3
1 Features of product	4
2 Dimension diagram	4
3 Bundled items	5
4 Installation instructions	5
4.1 Cautions on mounting	5
4.2 Example of combination mounting	5
4.3 The mount to IEC35mm rail (DIN rail), and the method of detachment	6
4.4 Mounting by screws	6
5 Wiring	7
6 Operation	9
6.1 Names and functions of parts	9
6.2 Basic operation	9
6.3 Display configuration	10
7 Measurement mode	10
7.1 Measurement display	10
7.2 Maximum value / Minimum value reset	11
8 Settings change mode	12
8.1 Flowchart for changing settings	12
8.2 How to change settings	13
8.3 Settings menu	13
9 Settings confirmation mode	17
9.1 Flowchart for settings confirmation	17
9.2 How to settings confirmation	17
9.3 Settings confirmation menu	18
10 Test mode	20
11 Error display	20
12 Specification	21
12.1 Ratings	21
12.2 Performance	21
12.3 Alarm output	24
12.4 List of units	28
13 Inspection and calibration	29
13.1 Inspection	29
13.2 Calibration	29
14 Troubleshooting	30

Overview

Thank you for your purchase of DAIICHI electronics product.

Please read this instruction manual carefully before use.

Keep this manual for future reference. Please contact us if this manual is lost or damaged.

Safety precautions

■ Environment conditions

Please be sure to use this product in a place that meets the following conditions.

In places that do not meet this condition, it may cause malfunction or failure and product life decline.

- Within the range of ambient temperature -10 to 55°C , humidity 5 to 90% RH.
- Environment with low corrosive gas, dust, salt and oil smoke. (Corrosive gas: $\text{SO}_2/\text{H}_2\text{S}$, etc.)
- Environment that is not affected by vibration or shock.
- Environment with less external noise.
- Altitude 2000m or less.

■ Outdoor use conditions

- These products are not dustproof, waterproof, and splash proof construction. Please avoid the place with much dust. Moreover, please install in the place not exposed to rain or water drop. (Ingress Protection: IP40)
- Please do not install in the place where sunlight hits directly. Discoloration and degradation of a name plate, and deformation of the case by the surface temperature rise may occur.
- Product lifespan decreases when the ambient daily average temperature exceeds 40°C .

■ Mounting and wiring

Please refer to this instruction manual for mounting and the wiring.



CAUTION

- Please refer to connection diagram for the wiring.
- Please avoid hot line work.
- Please use an electrical wire size suitable with the rated current.
- Please check the tightening of the screw.

■ Preparation

This product must be set before use. Please read this user manual carefully and set up the device correctly.

■ Maintenance and inspection

- Inspection in energized state is dangerous.
- This product has no parts to replace during regular inspections.
- During inspections, take care to ensure that output wires and human bodies do not come into contact with the input and power supply terminals.
- Please check that the power LED (POWER) is lit properly.
- Please check that there are no loose wires or loose mounting screws.
- If dust has adhered to this product, please wipe off lightly with the dry soft cloth. Please do not use organic solvents, chemicals, cleaners, etc., such as alcohol, for cleaning.

■ Storage

Please store in a place that meets the following conditions.

- Within the range of ambient temperature -25 to 70°C , humidity 5 to 90% RH.
- Daily average temperature 40°C or less.
- Environment with low corrosive gas, dust, salt and oil smoke.
- Environment that is not affected by vibration or shock.
- Aluminum electrolytic capacitors are used in products. Please energize the power supply within one year after purchase.

■ Countermeasures against troubles

If trouble occurs within the warranty period, DAIICHI ELECTRONICS will repair this product.

■ Countermeasures against troubles

Please dispose of this product as industrial waste (non-combustible).

Mercury parts and a nickel-cadmium battery are not used for this product.

■ Warranty period

The warranty period of the product is one year after the date of delivery.

■ Warranty scope

In the state of the normal use of product-specification within the range according to this instruction manual, this product in trouble within the warranty period will be performed exchange or repair gratuitously. However, it is not warranted in the following cases.

① If it breaks down when converted or repaired without us.

② If it breaks down by use out of specification range.

③ If the cause of trouble is based on cause other than this product.

④ Damage and trouble by transportation, movement, and falling.

⑤ In other cases where the supplier is not responsible due to disasters, etc.

This warranty is a warranty only for the delivered product.

Cannot warrant the damage induced by trouble of this product.

■ Replacement cycle of the product

We recommend updating the product for 10 years as a rough standard.

■ Change of instruction manual written contents.

This instruction manual changes written contents without a notice by product improvement etc.

Composition of type

Type

Specification code

SDEL-105-

① Input (Input resistance)		② Output contact configuration		③ Power supply	
A3	DC0 to 60mV (Approx. 1MΩ)	1	Alarm output : 2 points	F	AC80 to 264V
A5	DC0 to 1V (Approx. 1MΩ)		Change-over contact (N.O./N.C.)		DC80 to 264V
A6	DC0 to 5V (Approx. 1MΩ)	2	Alarm output : 3 points	5	DC19 to 29V
A7	DC0 to 10V (Approx. 1MΩ)		Make contact (N.O.)		
A8	DC1 to 5V (Approx. 1MΩ)	3	Alarm output : 3 points	0	Other
B3	DC±60mV (Approx. 1MΩ)		Break contact (N.C.)		
B5	DC±1V (Approx. 1MΩ)	4	Alarm output : 4 points	0	Other
B6	DC±5V (Approx. 1MΩ)		Make contact (N.O.)		
B7	DC±10V (Approx. 1MΩ)	5	Alarm output : 4 points	0	Other
C3	DC0 to 1mA (Approx. 100Ω)		Break contact (N.C.)		
C4	DC0 to 5mA (Approx. 100Ω)	0	Other	0	Other
C5	DC0 to 10mA (Approx. 100Ω)				
C6	DC0 to 16mA (Approx. 100Ω)	0	Other	0	Other
C7	DC4 to 20mA (Approx. 100Ω)				
00	Other (Voltage input range : 60mV to 60V) (Current input range : 1mA to 50mA)	0	Other	0	Other

1 Features of product

- Alarm outputs can be selected from 2 points (Change-over contact [N.O./N.C.]), 3 points (Make contact [N.O.]) or Break contact [N.C.], or 4 points (Make contact [N.O.] or Break contact [N.C.]).
- Measurement display and setting changes can be made via a high-contrast organic EL panel.
- The operating status of the outputs is indicated by a monitor lamp (red) on the front of the unit.
- The test function allows you to verify the operation of the alarm output without applying an input.
- Equipped with setting functions such as output mode (upper / lower limit, excitation / non-excitation), dead band, starting delay, and contact delay.

2 Dimension diagram

(1) Main unit and socket

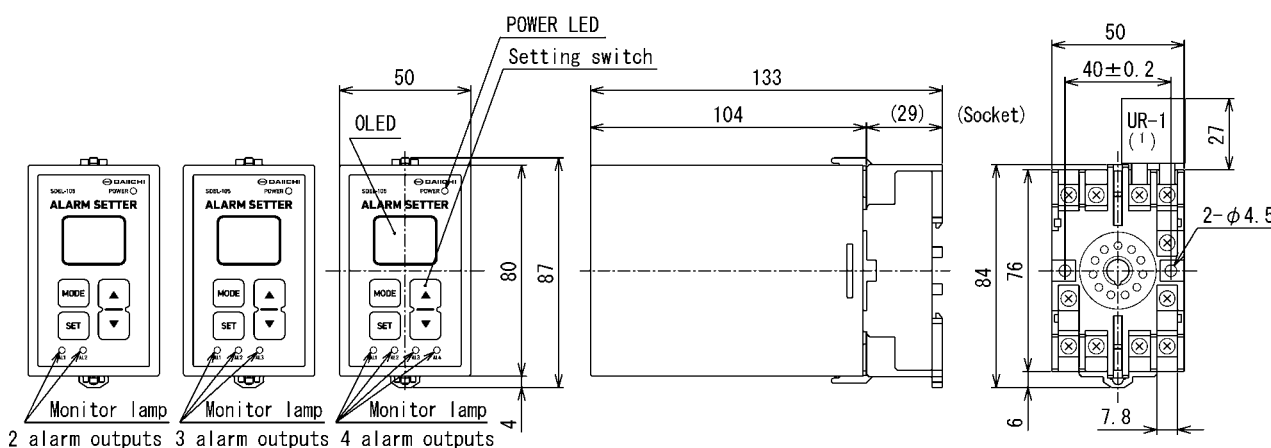

Note⁽¹⁾ The UR-1 is sold separately.

Please use it in combination with a voltage-input alarm setter.

When replacing an alarm setter with live current inputs, if open-circuit protection is required, connect the UR-1 to the socket to convert the signal to a voltage signal before use. (UR-1, specified resistance value)

(2) Precision Resistance Unit, Type : UR-1 (Sold separately)

The UR-1 is used to prevent open circuits when replacing the alarm setter while the circuit is live during current input.

To install the UR-1, connect it to terminals 5 and 6 of the socket along with the input wires.

Resistance value of UR-1 in input signal.

Current signal Resistance	DC0 to 1mA	DC0 to 10mA	DC0 to 16mA	DC0 to 20mA	DC2 to 10mA	DC4 to 20mA	DC10 to 50mA
10Ω	—	DC0 to 100mV	DC0 to 160mV	DC0 to 200mV	DC20 to 100mV	DC40 to 200mV	DC100 to 500mV
50Ω	—	—	—	DC0 to 1V	DC100 to 500mV	DC0.2 to 1V	DC0.5 to 2.5V
62.5Ω	—	—	DC0 to 1V	—	—	DC0.25 to 1.25V	—
100Ω	DC0 to 100mV	DC0 to 1V	—	—	—	DC0.4 to 2V	DC1 to 5V
250Ω	—	—	—	DC0 to 5V	—	DC1 to 5V	—
500Ω	—	DC0 to 5V	—	DC0 to 10V	DC1 to 5V	—	—
1kΩ	DC0 to 1V	DC0 to 10V	—	—	—	—	—

4.3 The mount to IEC35mm rail (DIN rail), and the method of detachment

<Note> If it insert and remove the body section from a socket, please carry out after shutting down a power supply and an input signal.

(1) How to fix a socket.

Set the base socket so that its slider is at the bottom. Position the upper hook at the rear side of base socket on the IEC35mm rail (DIN rail) and push in the lower.

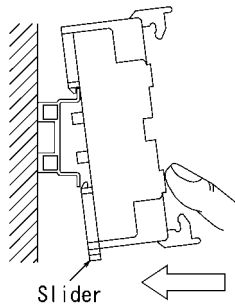

(2) How to fix a body to a socket.

Do in the direction which can read a label character correctly and insert a body straightly. After inserting it all the way in, please fix the main body with the yellow stopper of the socket.

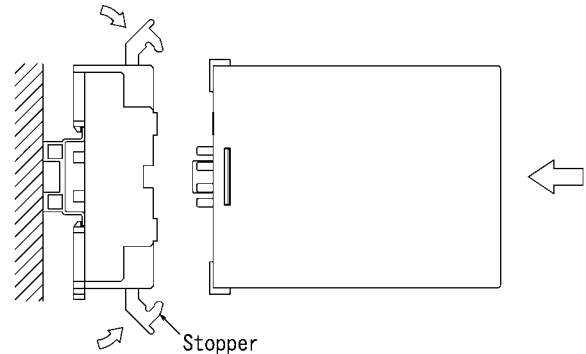

(3) How to remove a body from a socket.

Remove the stopper of the socket from the main body. Please pull a body to straight near side.

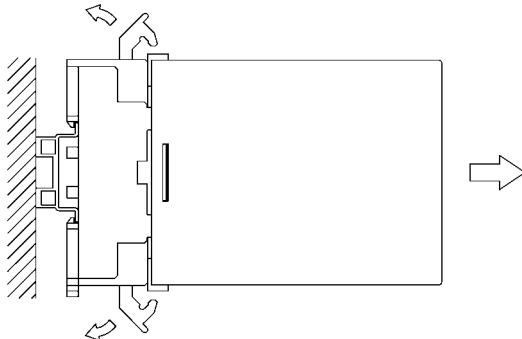

(4) How to remove a socket.

Push down the slider utilizing a minus screwdriver and pull.

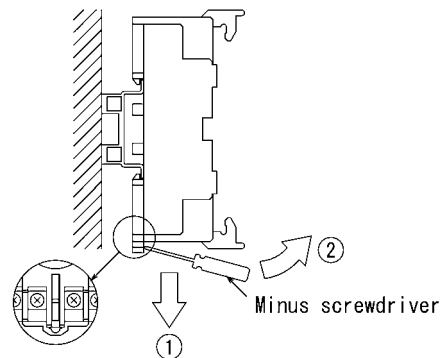

<Note>

If a transducer body is taken out and inserted aslant, the terminal of a body will bend and a loose connection etc. will occur.

4.4 Mounting by screws

Remove the stopper of the socket from the main body. Please pull a body to straight near side. Install the socket with M4 screw and attach the main unit after wiring. (However, screws are not included, tightening torque of screw 4 : 1.08 to 1.47N·m (11 to 15kg·cm))

5 Wiring

2 alarm outputs
Each change-over contact
(N.O./N.C.)

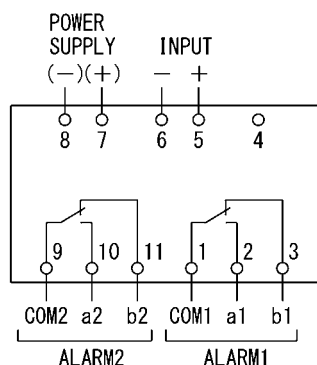

3 alarm outputs
Each make contact (N.O.)

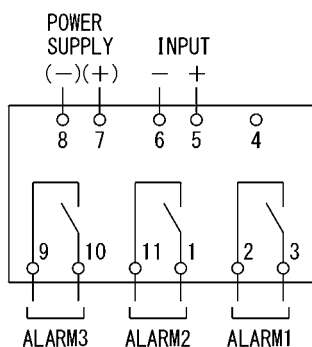

3 alarm outputs
Each break contact (N.C.)

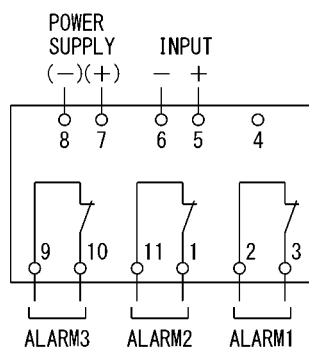

4 alarm outputs
Each make contact (N.O.)

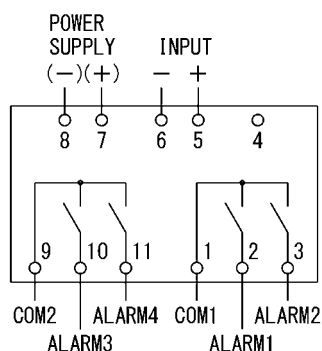

4 alarm outputs
Each break contact (N.C.)

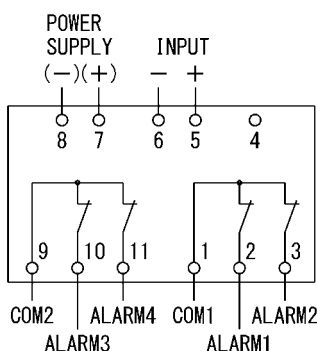

Socket terminal diagram

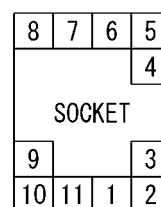

Please refer to the wiring diagram above.

The polarity in parentheses applies when the power supply is DC.

The tightening torque for terminal screws is 0.7 to 0.9N·m (7.1 to 9.2kg·cm) for M3.5 screws.

<Caution>

Working while the power is on or the input is connected is dangerous.

Be sure to turn off the power before performing any work.

Do not touch terminals or other components with wet hands during cleaning or inspection, as this may result in electric shock.

Incorrect wiring of the power supply or inputs may cause burnout, so please exercise extreme caution when wiring. In addition, it is dangerous to perform inspections in areas where flammable materials, chemicals, or gases are present.

When connecting inductive loads, such as electromagnetic relays, to the output terminals, we recommend installing diodes or surge killer.

《The example of spark quenching method circuit》

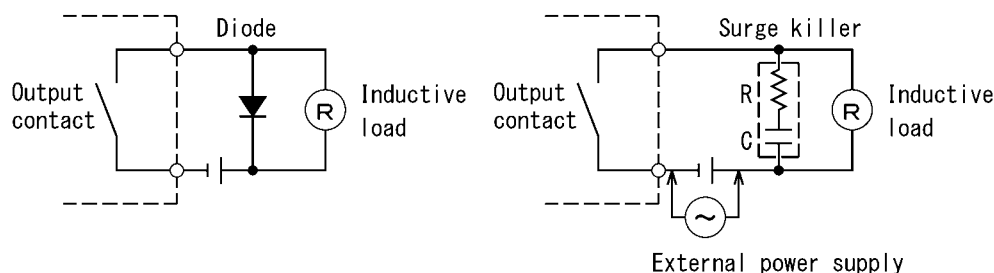

- Precautions for installation

- (1) Installation status

- There is no limit of a mounting position.

- The installation can select IEC35mm rail (DIN rail) mounting and screw mounting.

- In screw mounting, please install with M4 screw.

- The tightening torque of screw, M4 : 1.08 to 1.47N·m (11 to 15kg·cm).

- However, the screw is not attached.

- Leave a space of at least 5 mm between adjacent units to allow for heat dissipation and leave a space of at least 100 mm above and below to allow for heat dissipation and wiring space.

- (2) Wiring status

- When transmitting the Alarm Setter' s output directly over long distances, even if the transmission line is susceptible to interference from induced lightning surges or other sources, this unit includes a built-in protection circuit. Therefore, no additional protection is required on the output side of this unit.

- However, to protect the receiving equipment, please install line-to-line surge protectors and an arrester rated for approximately 500 V between the transmission line and ground on the receiving equipment side.

- Please separate wiring of input and output and perform consideration to noise.

- And please separate from a line with the power line used as the source of noise and steep voltage, and current as much as possible. Please use shielding wire for the bottom of the remarkable environment of noise.

- (3) Environmental conditions

- ① Ambient temperature and humidity range

- Please ensure that the ambient temperature and humidity for each device remain within the following ranges.

- Temperature : -10 to +55°C, Humidity : 5 to 90% RH (Non condensing)

- ② Environment atmosphere

- The case has sealing construction. However, be careful of employment under environment with much dust.

- Please consult on the occasion of the employment under corrosive gas environment, such as hydrogen sulfide gas (H₂S) and chlorine gas (Cl).

6 Operation

6.1 Names and functions of parts

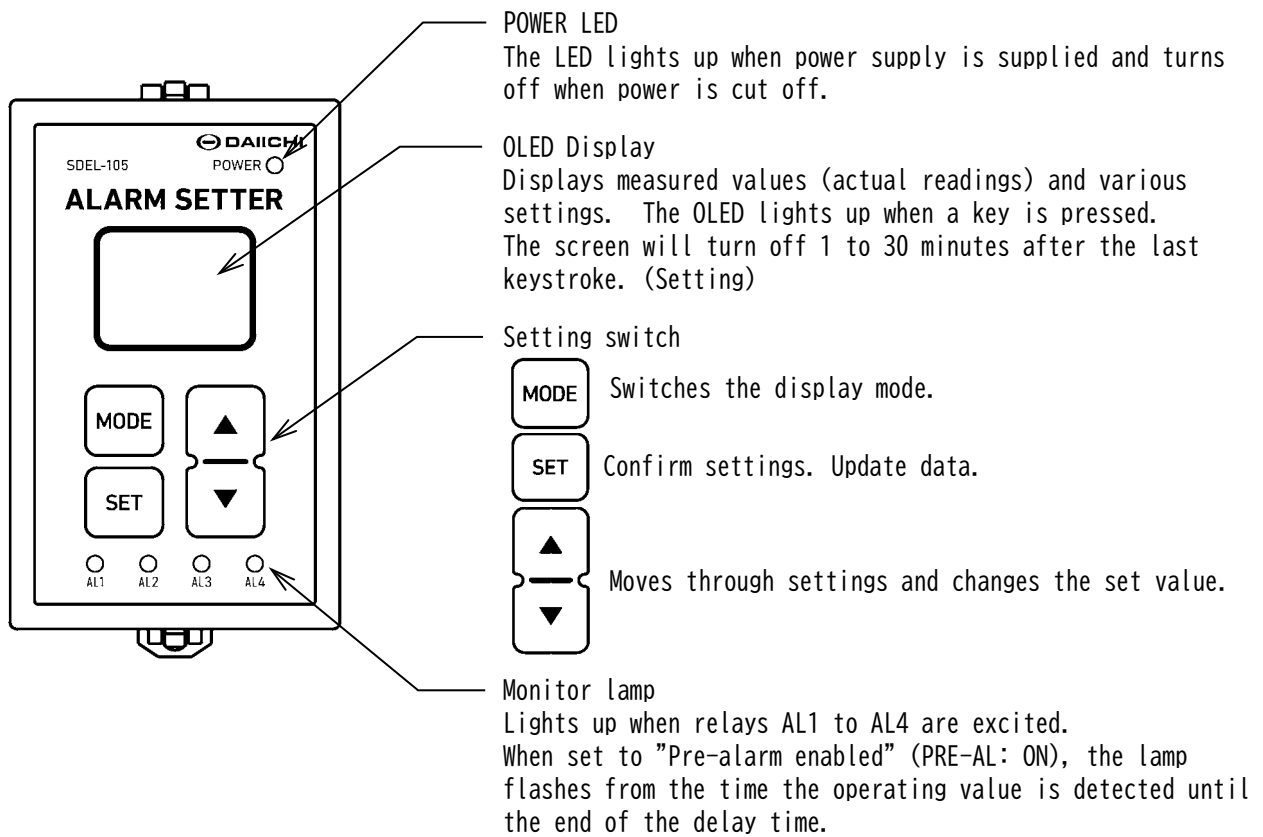

<Note> Do not apply excessive force to the setting switch.
Applying excessive force will put stress on the front panel and affect the display.

6.2 Basic operation

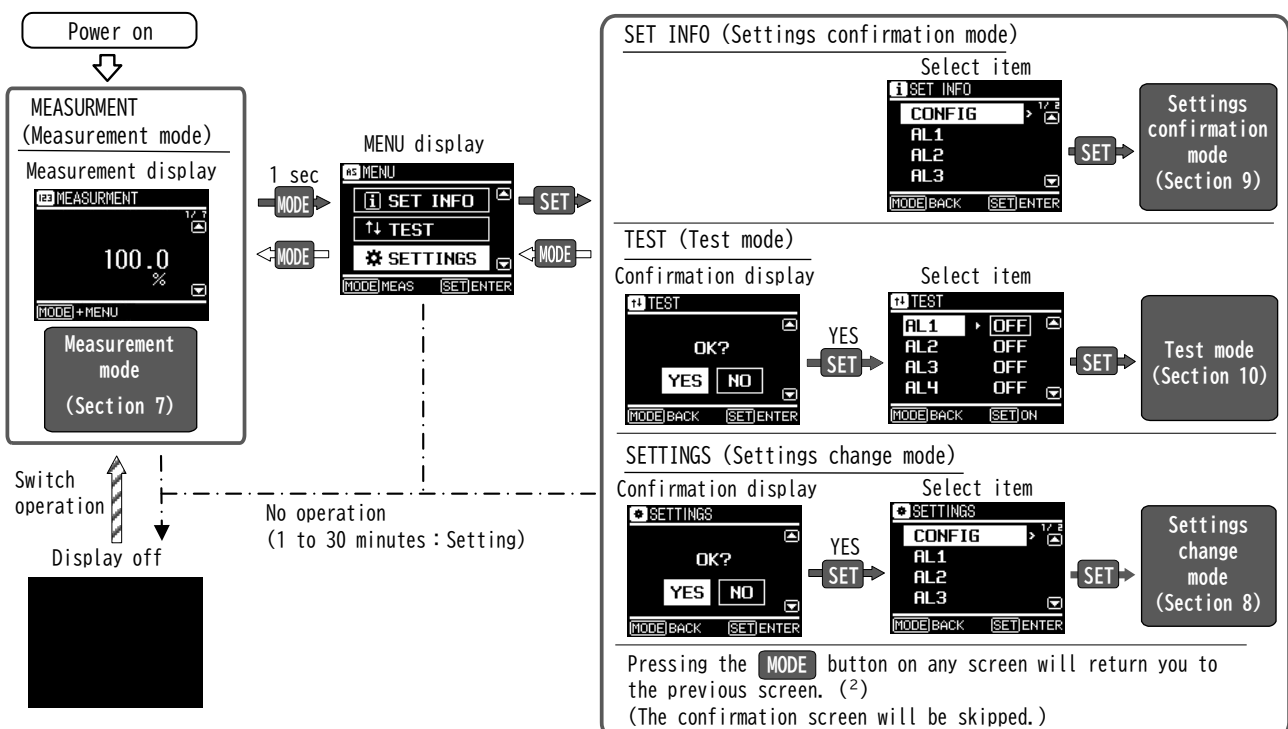

Note(2) Press and hold for 1 second or longer to return to the MENU display from any display.

6.3 Display configuration

Display

- Display name
- Main display
Displays item names, settings, measured values, and other information.
- Cursor position (Invert colors)
- Switch icon
Indicates operation using the ▲▼ keys.
- Operation Guide
Displays the action performed when the switch is operated.



7 Measurement mode

7.1 Measurement display

(1) Display

Example : Instantaneous measurement

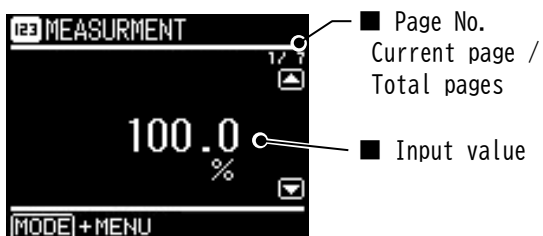

Example : Alarm output 1 status

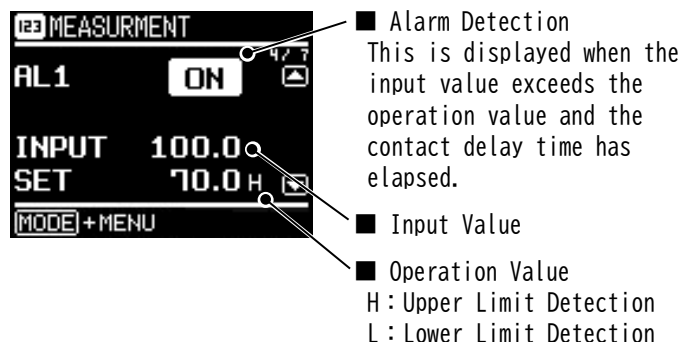

(2) Operation

- ① After powering on, the device automatically enters [Measurement mode].
- ② Use the ▲ ▼ switches to select the measurement element (see table below) you wish to display.

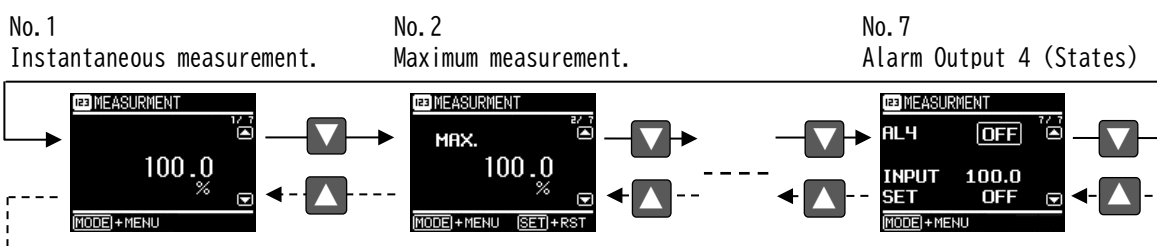

(3) Measurement items

Page No.	Measurement elements
1	Instantaneous measurement
2	Maximum measurement
3	Minimum measurement
4	Alarm Output 1 status
5	Alarm Output 2 status
6	Alarm Output 3 status ⁽³⁾
7	Alarm Output 4 status ⁽⁴⁾

Note⁽³⁾ 3 alarm outputs and 4 alarm outputs only

Note⁽⁴⁾ 4 alarm outputs only

7.2 Maximum value / Minimum value reset

(1) Display

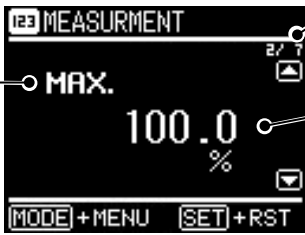

■ Maximum measurement display

■ Page No.
Current page / Total pages

■ Input value

Page No.	Setting item
2	Maximum measurement
3	Minimum measurement

(2) Operation

- ① [Measurement mode], use the ▲ ▼ switch to display the maximum or minimum scaling value.
- ② Press and hold the **SET** switch for at least 3 seconds.

Example : Maximum scaling value

Reset complete

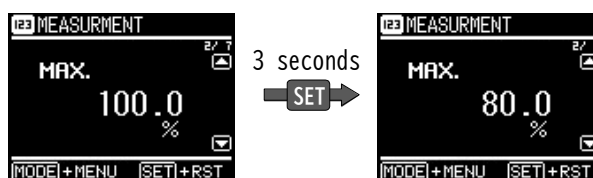

<Caution> Please display the scaling to be reset before performing the reset operation.
Only the currently displayed values will be reset.

8 Settings change mode

8.1 Flowchart for changing settings

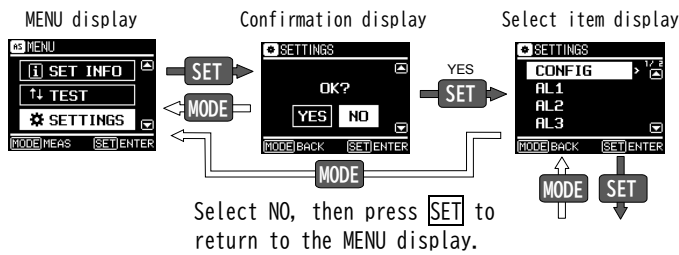

Use ▲ ▼ to select a setting item.

Caution
After changing settings, be sure to return to the MENU screen. If you do not return to the MENU screen, your settings will not be protected during a power outage.

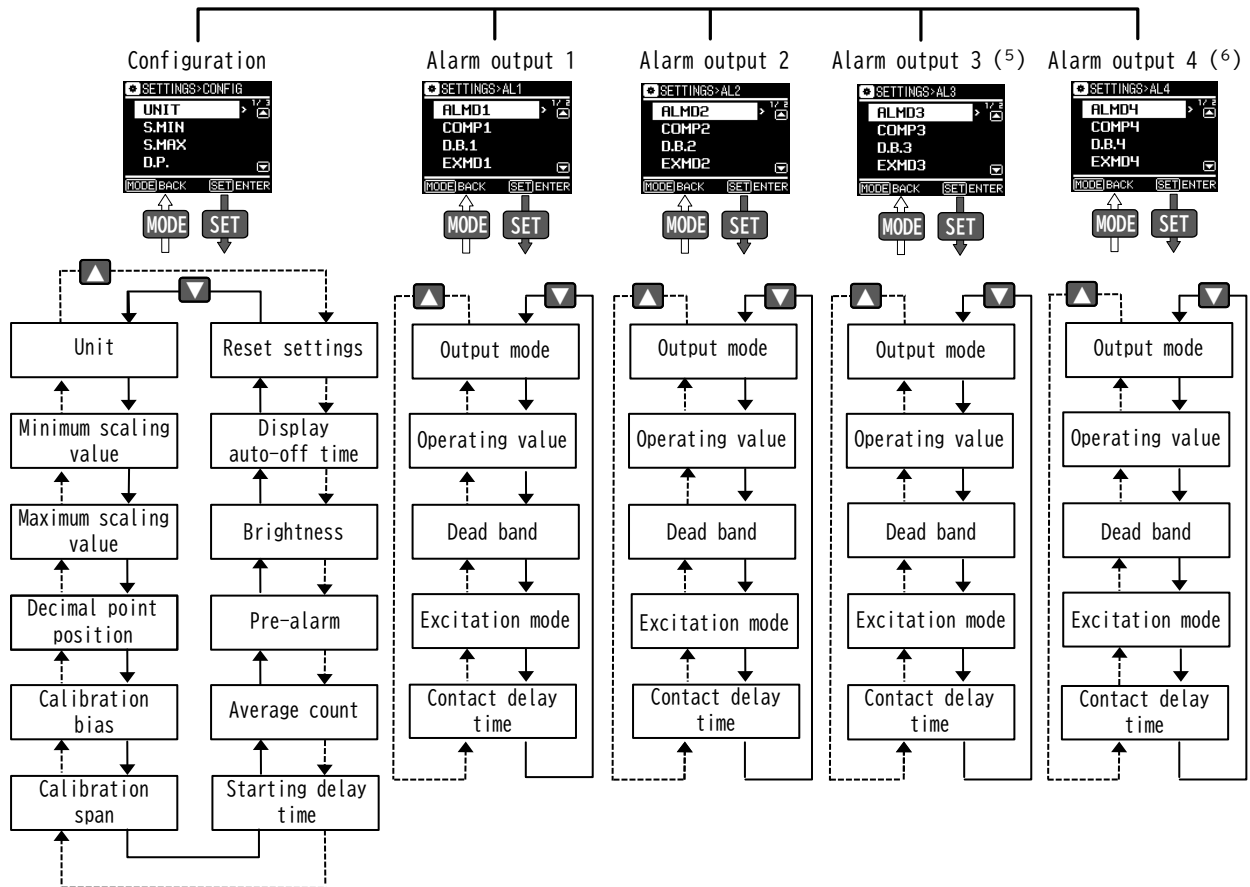

Note⁽⁵⁾ 3 alarm outputs and 4 alarm outputs only

Note⁽⁶⁾ 4 alarm outputs only

8.2 How to change settings

(1) Display

Example: Unit setting

Example: Operation value setting

- Setting item
- Setting unit No.
- Current setting value (Check mark: ✓)
- Switch icon Operate the ▲▼.
- Setting value (numerical value) ▲▼ in the increase or decrease.
- Operation guidance Display the operation at the time of switch operation.

(2) Operation

- ① On each settings screen, use ▲ ▼ to change the setting value and press SET to confirm.
- ② Once confirmed, a "check mark: ✓" indicating the current setting will appear next to the changed setting value.
- ③ If there are many setting values, press and hold ▲ ▼ to scroll through them quickly.



<Caution> After changing settings, be sure to return to the MENU screen.

If you do not return to the MENU screen, your settings will not be protected during a power outage.

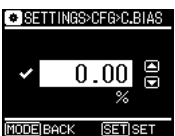
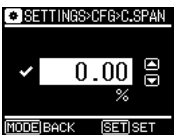
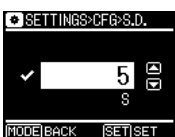

8.3 Settings menu

(1) CONFIG

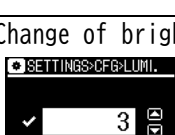
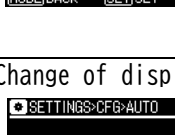
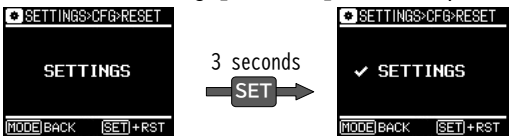
Setting item	Description	Content											
Unit 【UNIT】	Set the unit for the input value.	【Change of Units】 	<table border="1"> <thead> <tr> <th colspan="2">Setting range</th> </tr> </thead> <tbody> <tr> <td colspan="2">Select 1 unit from the 129 units</td> </tr> <tr> <td colspan="2">For details, please refer to "12.4 List of units".</td> </tr> </tbody> </table>	Setting range		Select 1 unit from the 129 units		For details, please refer to "12.4 List of units".					
Setting range													
Select 1 unit from the 129 units													
For details, please refer to "12.4 List of units".													
Minimum scaling value 【S. MIN】	Set the minimum scaling value.	【Change of minimum scaling value】 	<table border="1"> <thead> <tr> <th colspan="2">Setting range</th> </tr> </thead> <tbody> <tr> <td>-9999 to 9998</td> <td>1 step</td> </tr> </tbody> </table> <p><Note> Changing the scaling will also change the alarm operating value accordingly.</p>	Setting range		-9999 to 9998	1 step						
Setting range													
-9999 to 9998	1 step												
Maximum scaling value 【S. MAX】	Set the maximum scaling value.	【Change of maximum scaling value】 	<table border="1"> <thead> <tr> <th colspan="2">Setting range</th> </tr> </thead> <tbody> <tr> <td>-9998 to 9999</td> <td>1 step</td> </tr> </tbody> </table> <p><Note> Changing the scaling will also change the alarm operating value accordingly.</p>	Setting range		-9998 to 9999	1 step						
Setting range													
-9998 to 9999	1 step												
Decimal point position 【D. P.】	Set the decimal point position for the maximum and minimum scaling values and the operating value.	【Change of decimal point position】 	<table border="1"> <thead> <tr> <th colspan="2">Setting range</th> </tr> </thead> <tbody> <tr> <td>0000</td> <td>(No decimal point)</td> </tr> <tr> <td>000.0</td> <td></td> </tr> <tr> <td>00.00</td> <td></td> </tr> <tr> <td>0.000</td> <td></td> </tr> </tbody> </table> <p><Note> When changing the decimal point position, check the maximum and minimum scaling settings and the operating values.</p>	Setting range		0000	(No decimal point)	000.0		00.00		0.000	
Setting range													
0000	(No decimal point)												
000.0													
00.00													
0.000													

Setting item	Description	Content												
Calibration bias 【C. BIAS】	Set the bias point for the input value.	<p>【Change of calibration bias】</p>  <table border="1"> <thead> <tr> <th colspan="2">Setting range</th> </tr> </thead> <tbody> <tr> <td>-9.99 to 9.99%</td> <td>0.1 step</td> </tr> </tbody> </table>	Setting range		-9.99 to 9.99%	0.1 step								
Setting range														
-9.99 to 9.99%	0.1 step													
Calibration span 【C. SPAN】	Set the span point for the input value.	<p>【Change of calibration span】</p>  <table border="1"> <thead> <tr> <th colspan="2">Setting range</th> </tr> </thead> <tbody> <tr> <td>-9.99 to 9.99%</td> <td>0.1 step</td> </tr> </tbody> </table>	Setting range		-9.99 to 9.99%	0.1 step								
Setting range														
-9.99 to 9.99%	0.1 step													
Starting delay time 【S.D.】	Set the time between applying the power supply and the contacts actuating.	<p>【Change of starting delay time】</p>  <table border="1"> <thead> <tr> <th colspan="2">Setting range</th> </tr> </thead> <tbody> <tr> <td colspan="2">1 to 180 seconds</td> </tr> </tbody> </table>	Setting range		1 to 180 seconds									
Setting range														
1 to 180 seconds														
Average count 【AVE】	Set the average number (average count) of internal measurement operations.	<p>【Change of average count】</p>  <table border="1"> <thead> <tr> <th colspan="2">Setting range</th> </tr> </thead> <tbody> <tr> <td>1</td> <td>Data update, Fast</td> </tr> <tr> <td>4</td> <td>↑</td> </tr> <tr> <td>8</td> <td></td> </tr> <tr> <td>16</td> <td>↓</td> </tr> <tr> <td>32</td> <td>Data update, Slow</td> </tr> </tbody> </table>	Setting range		1	Data update, Fast	4	↑	8		16	↓	32	Data update, Slow
Setting range														
1	Data update, Fast													
4	↑													
8														
16	↓													
32	Data update, Slow													
Pre-alarm 【PRE-AL】	Set whether the monitor lamp should flash before the set value is reached.	<p>【Change of pre-alarm】</p>  <table border="1"> <thead> <tr> <th colspan="2">Setting range</th> </tr> </thead> <tbody> <tr> <td colspan="2">ON</td> </tr> <tr> <td colspan="2">OFF</td> </tr> </tbody> </table>	Setting range		ON		OFF							
Setting range														
ON														
OFF														
Brightness 【LUMI.】	Set the brightness of the OLED display.	<p>【Change of brightness】</p>  <table border="1"> <thead> <tr> <th colspan="2">Setting range</th> </tr> </thead> <tbody> <tr> <td>5</td> <td>Bright</td> </tr> <tr> <td>4</td> <td>↑</td> </tr> <tr> <td>3</td> <td></td> </tr> <tr> <td>2</td> <td>↓</td> </tr> <tr> <td>1</td> <td>Dark</td> </tr> </tbody> </table>	Setting range		5	Bright	4	↑	3		2	↓	1	Dark
Setting range														
5	Bright													
4	↑													
3														
2	↓													
1	Dark													
Display auto-off time 【AUTO-OFF】	Set the auto-off time for the OLED display.	<p>【Change of display auto-off time】</p>  <table border="1"> <thead> <tr> <th colspan="2">Setting range</th> </tr> </thead> <tbody> <tr> <td>1 minute</td> <td>10 minutes</td> </tr> <tr> <td>2 minutes</td> <td>15 minutes</td> </tr> <tr> <td>5 minutes</td> <td>30 minutes</td> </tr> </tbody> </table>	Setting range		1 minute	10 minutes	2 minutes	15 minutes	5 minutes	30 minutes				
Setting range														
1 minute	10 minutes													
2 minutes	15 minutes													
5 minutes	30 minutes													
Restore to default settings 【RESET】	Resets all settings (SETTINGS).	<ul style="list-style-type: none"> Press and hold the SET switch for at least 3 seconds to reset (initialize). When the reset is complete, a check mark (✓) will appear to the left of the item. <p>【Restore to settings】 【Reset Complete】</p>  <p><Note> If you perform an initialization, any settings you have changed will be overwritten with their default values. Please note that if the unit was shipped with specific settings, those settings will not be restored.</p>												

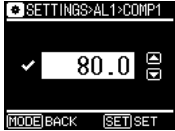
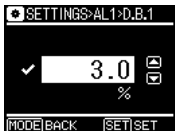
(2) Alarm output settings, AL1 to AL4 (Specify)

Setting item	Description	Content					
Output mode 【ALMD】	Set the signal state when the operating value is reached.	【Change of output mode】 	<table border="1"> <tr><th>Setting range</th></tr> <tr><td>HIGH (H operation)</td></tr> <tr><td>LOW (L operation)</td></tr> <tr><td>OFF (No operation)</td></tr> </table>	Setting range	HIGH (H operation)	LOW (L operation)	OFF (No operation)
Setting range							
HIGH (H operation)							
LOW (L operation)							
OFF (No operation)							
Operating value 【COMP】	Set the operating value to be detected.	【Change of operating value】 	<table border="1"> <tr><th>Setting range</th></tr> <tr><td>-25 to 125%</td></tr> </table> <p><Note> Changing the scaling will also change the alarm operating value accordingly.</p>	Setting range	-25 to 125%		
Setting range							
-25 to 125%							
Dead band 【D.B.】	Set the range before and after the operating value that will not be judged.	【Change of dead band】 	<table border="1"> <tr><th>Setting range</th></tr> <tr><td>0.5 to 50.0%</td></tr> </table>	Setting range	0.5 to 50.0%		
Setting range							
0.5 to 50.0%							
Excitation mode 【EXMD】	Set the relay operation when detection occurs.	【Change of excitation mode】 	<table border="1"> <tr><th>Setting range</th></tr> <tr><td>ON (Excitation)</td></tr> <tr><td>OFF (Non-excitation)</td></tr> </table> <p>For details, please refer to “Section 12.3 (2) Operation of alarm output” .</p>	Setting range	ON (Excitation)	OFF (Non-excitation)	
Setting range							
ON (Excitation)							
OFF (Non-excitation)							
Contact delay time 【C.D.】	Set the time from detection to contact operation.	【Change of contact delay time】 	<table border="1"> <tr><th>Setting range</th></tr> <tr><td>0 to 180 seconds</td></tr> </table>	Setting range	0 to 180 seconds		
Setting range							
0 to 180 seconds							

<Notes on Settings>

Operating values can be set within a range of -25% to +125% or 9999 to 9999 (decimal point depend on the settings) relative to the scaling factor.

Changing the scaling will also change the alarm operating value accordingly.

(Example) Input : 4 to 20mA, Operation value : -25.0, Output mode : Low

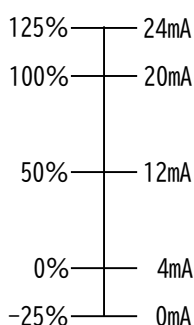

Since an “L” is detected at 0mA input, it can also be used for open-circuit detection.

(3) Default settings

Item		Guidance	Default Settings			
			2 alarm outputs	3 alarm outputs	4 alarm outputs	
CONFIG	Unit	UNIT	%			
	Scaling	Minimum value	S. MIN	0.0		
		Maximum value	S. MAX	100.0		
		Decimal point	D. P.	000.0		
	Calibration	Bias	C. BIAS	0.00%		
		Span	C. SPAN	0.00%		
	Starting delay	S. D.	5 seconds			
	Average count	AVE	1			
	Pre-alarm	PRE-AL	OFF			
Brightness	LUMI.	3				
Display auto-off time	AUTO-OFF	10 minutes				
ALARM1	Output mode	ALMD1	HIGH	HIGH	HIGH	
	Operating value	COMP1	70.0	80.0	80.0	
	Dead band	D. B. 1	3.0%			
	Excitation mode	EXMD1	ON			
	Contact delay time	C. D. 1	0 seconds			
ALARM2	Output mode	ALMD2	LOW	HIGH	HIGH	
	Operating value	COMP2	30.0	70.0	70.0	
	Dead band	D. B. 2	3.0%			
	Excitation mode	EXMD2	ON			
	Contact delay time	C. D. 2	0 seconds			
ALARM3	Output mode	ALMD3	—	LOW	LOW	
	Operating value	COMP3	—	30.0	30.0	
	Dead band	D. B. 3	—	3.0%		
	Excitation mode	EXMD3	—	ON		
	Contact delay time	C. D. 3	—	0 seconds		
ALARM4	Output mode	ALMD4	—	LOW		
	Operating value	COMP4	—	20.0		
	Dead band	D. B. 4	—	3.0%		
	Excitation mode	EXMD4	—	ON		
	Contact delay time	C. D. 4	—	0 seconds		

9 Settings confirmation mode

9.1 Flowchart for settings confirmation

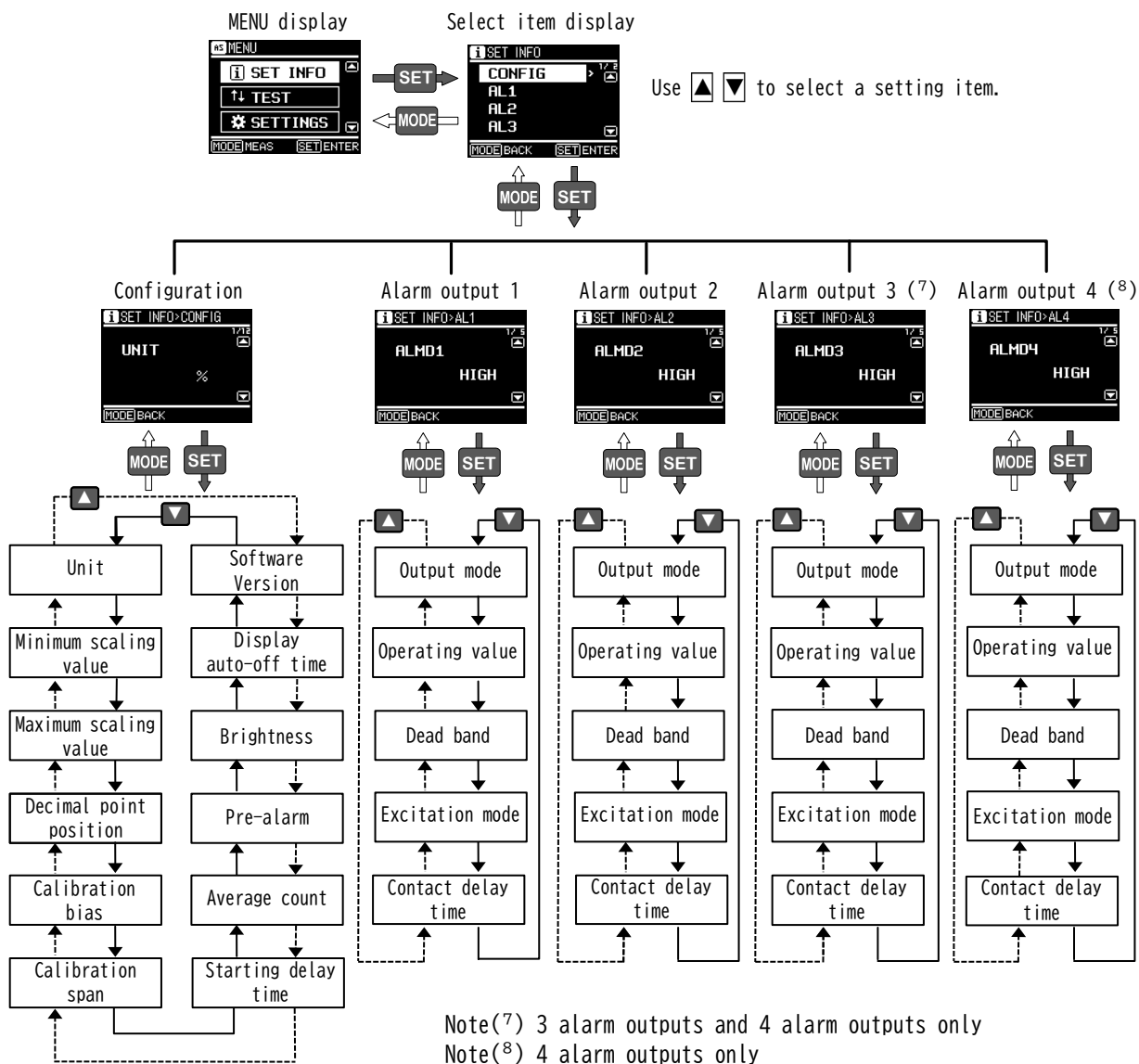

9.2 How to settings confirmation

(1) Display

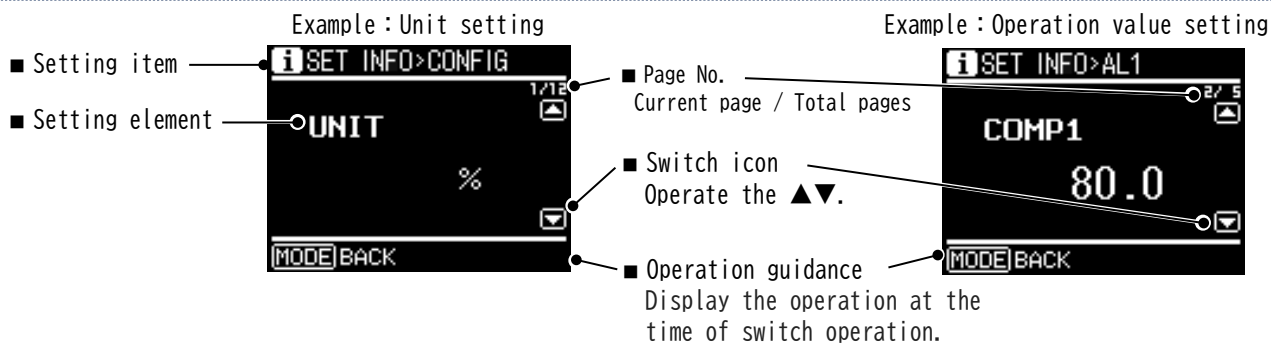







(2) Operation



On each settings screen, use the ▲ and ▼ switches to view the settings.

<Note> Settings cannot be changed on the settings confirmation screen.

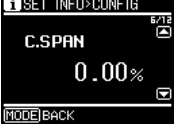

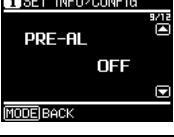

9.3 Settings confirmation menu

(1) CONFIG

Setting item	Description	Content
Unit 【UNIT】	Display the unit for the input value.	【Unit display】 
Minimum scaling value 【S. MIN】	Display the minimum scaling value.	【Minimum scaling value display】 
Maximum scaling value 【S. MAX】	Display the maximum scaling value.	【Maximum scaling value display】 
Decimal point position 【D. P.】	Display the decimal point position for the maximum and minimum scaling values and the operating value.	【Decimal point position display】 
Calibration bias 【C. BIAS】	Display the bias point for the input value.	【Calibration bias display】 
Calibration span 【C. SPAN】	Display the span point for the input value.	【Calibration span display】 
Starting delay time 【S. D.】	Display the time between applying the power supply and the contacts actuating.	【Starting delay time display】 
Average count 【AVE】	Display the average number (average count) of internal measurement operations.	【Average count display】 
Pre-alarm 【PRE-AL】	Display whether the monitor lamp should flash before the set value is reached.	【Pre-alarm display】 

Setting item	Description	Content
Brightness 【LUMI.】	Display the brightness of the OLED display.	【Brightness display】 
Display auto-off time 【AUTO-OFF】	Display the auto-off time for the OLED display.	【Display auto-off time display】 
Software version 【SOFTWARE】	Displays the software version	【Software version display】  <u>Version :</u> <u>3 alphanumeric digits</u>

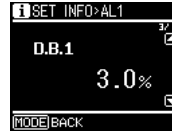
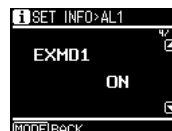
(2) Alarm output settings, AL1 to AL4 (Specify)

Setting item	Description	Content
Output mode 【ALMD】	Display the signal state when the operating value is reached.	【Output mode display】 
Operating value 【COMP】	Display the operating value to be detected.	【Operating value display】 
Dead band 【D.B.】	Display the range before and after the operating value that will not be judged.	【Dead band display】 
Excitation mode 【EXMD】	Display the relay operation when detection occurs.	【Dead band display】 
Contact delay time 【C.D.】	Display the time from detection to contact operation.	【Dead band display】 

10 Test mode

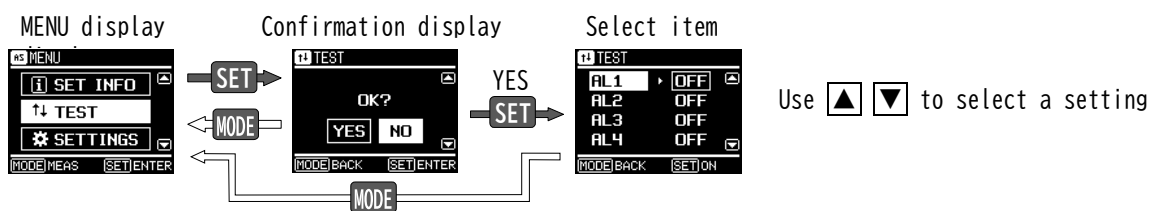

Select NO, then press **SET** to return to the MENU display.

Test item	Test content																									
Alarm output 1 to 4 (Specify)	<ul style="list-style-type: none"> Select the alarm output to test using [Up] [Down] and output it with SET. 																									
	<ul style="list-style-type: none"> Test operation <table border="1"> <thead> <tr> <th>Contact configuration</th> <th>Display</th> <th>Relay</th> <th>Monitor Lamp</th> </tr> </thead> <tbody> <tr> <td rowspan="2">Make contact (N.O.)</td> <td>ON</td> <td>Excitation (Conduction)</td> <td>ON</td> </tr> <tr> <td>OFF</td> <td>Non-excitation (Open)</td> <td>OFF</td> </tr> <tr> <td rowspan="2">Break contact (N.C.)</td> <td>ON</td> <td>Excitation (Open)</td> <td>ON</td> </tr> <tr> <td>OFF</td> <td>Non-excitation (Conduction)</td> <td>OFF</td> </tr> <tr> <td rowspan="2">Change-over contact (N.O./N.C.)</td> <td>ON</td> <td>Excitation (Continuity on the make contact [N.O.] side)</td> <td>ON</td> </tr> <tr> <td>OFF</td> <td>Non-excitation (Continuity on the break contact [N.C.] side)</td> <td>OFF</td> </tr> </tbody> </table>	Contact configuration	Display	Relay	Monitor Lamp	Make contact (N.O.)	ON	Excitation (Conduction)	ON	OFF	Non-excitation (Open)	OFF	Break contact (N.C.)	ON	Excitation (Open)	ON	OFF	Non-excitation (Conduction)	OFF	Change-over contact (N.O./N.C.)	ON	Excitation (Continuity on the make contact [N.O.] side)	ON	OFF	Non-excitation (Continuity on the break contact [N.C.] side)	OFF
	Contact configuration	Display	Relay	Monitor Lamp																						
	Make contact (N.O.)	ON	Excitation (Conduction)	ON																						
OFF		Non-excitation (Open)	OFF																							
Break contact (N.C.)	ON	Excitation (Open)	ON																							
	OFF	Non-excitation (Conduction)	OFF																							
Change-over contact (N.O./N.C.)	ON	Excitation (Continuity on the make contact [N.O.] side)	ON																							
	OFF	Non-excitation (Continuity on the break contact [N.C.] side)	OFF																							
<p><Note> Make sure the monitor lamp is on. Normal detection operations are not performed during test mode.</p>																										

11 Error display

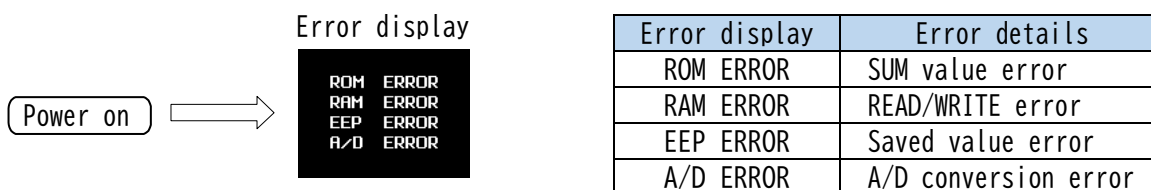

If an error occurs, the screen will switch to the error display.

<Note> If an error occurs, please turn the power off and then on again.

12 Specification

12.1 Ratings

Item		Specification	Notes
Input	DC voltage	DC \pm 60mV to \pm 10V (Input resistance 1M Ω \pm 10%)	Specify
	DC current	DC1mA to 20mA (Input resistance 100 Ω \pm 10%)	
Alarm output	Number of outputs	4 alarm outputs, 3 alarm outputs, 2 alarm outputs	Specify
	Contact composition	4 alarm outputs : Each make contact (N.O.), Each break contact (N.C.)	
		3 alarm outputs : Each make contact (N.O.), Each break contact (N.C.)	
		2 alarm outputs : Each change-over contact (N.O./N.C.)	
	Contact capacity	Maximum switching load AC120V 1A (COS ϕ =1), DC30V 1A (Resistance load)	
Minimum switching load DC5V 10mA			
Electric life	500,000 times or more (Switching frequency : 30 times / minute)		
Power supply	Power supply Power consumption	AC80 to 264V 50/60Hz (Rated voltage AC100/110V 3.6VA) (Rated voltage AC200/220V 4.5VA) DC80 to 264V (Rated voltage DC100/110V 2.0W) (Rated voltage DC200/220V 2.5W) AC/DC power supply	Specify
		DC19 to 29V (Rated voltage DC24V 2.5W)	
Power supply	Inrush Current	AC110V : 1.6A or less (Time constant : 2.8ms or less)	
		AC220V : 3.2A or less (Time constant : 2.8ms or less)	
		DC110V : 1.1A or less (Time constant : 2.8ms or less)	
		DC220V : 2.2A or less (Time constant : 2.8ms or less)	
		DC24V : 2.4A or less (Time constant : 8.7ms or less)	

12.2 Performance

Item	Specification	
Setting accuracy	Input range	Accuracy
	DC60mV to less than 1V	\pm 0.2% (% of input span)
	DC \pm 60mV to less than \pm 1V	
	DC1V to 60V	\pm 0.1% (% of input span)
	DC \pm 1V to \pm 60V	
	DC1mA to 50mA	
DC \pm 1mA to \pm 50mA		
Display accuracy	Input range	Accuracy
	DC60mV to less than 1V	If the measurement display span is less than 10,000 (5 digits excluding the decimal point), \pm 0.2% (% of input span) \pm 1digit.
	DC \pm 60mV to less than \pm 1V	If the measurement display span is 10,000 or more (5 digits excluding the decimal point), \pm 0.2% (% of input span) \pm 2 digit.
	DC1V to 60V	If the measurement display span is less than 10,000 (5 digits excluding the decimal point), \pm 0.1% (% of input span) \pm 1digit.
	DC \pm 1V to \pm 60V	
	DC1mA to 50mA	If the measurement display span is 10,000 or more (5 digits excluding the decimal point), \pm 0.1% (% of input span) \pm 2 digit.
DC \pm 1mA to \pm 50mA		

Item	Specifications		
Repeatability of operating point	$\pm 0.1\%$ (% of input span)		
Operating time ⁽⁹⁾	± 0.25 seconds of the contact delay time setting (However, when the setting is 0 second, 0.5 ± 0.25 seconds)		
Reset time ⁽¹⁰⁾	0.5 seconds or less		
Starting delay time	± 0.25 seconds of the start delay time setting		
Influence of temperature	0.2% (% of input span) / $23 \pm 10^\circ\text{C}$		
Influence of power supply voltage variations	0.1% (% of input span) / Within rated voltage range		
Operation period	About 0.1 seconds		
Response time	About 0.5 seconds If a step is given that changes the operating value setting from 90% to 110% at C.D.=0 seconds. ⁽¹¹⁾		
Display update time	About 0.5 seconds		
Measurement display	Display range	-9999 to 9999	Display of input span from 0 to 100%. Display scaling and decimal point position can be set as desired.
		-99.9 to 999.9	
		-9.99 to 99.99	
		0.000 to 9.999	
Unit display	Select and set one unit from a range of 129 units. For details, please refer to "12.4 List of units".		
Display function	OLED display		
	Display of measurement and setting values		
POWER LED	When the power supply is applied, the green LED lights up.		
Monitor Lamp	Red LED 4 points	AL1 : Lights up when the relay for alarm output 1 is excitation (conduction). When the pre-alarm settings (common to AL1 to AL4) is ON, the light flashes during the delay times.	
		AL2 : Lights up when the relay for alarm output 2 is excitation (conduction). When the pre-alarm settings (common to AL1 to AL4) is ON, the light flashes during the delay times.	
		AL3 : Lights up when the relay for alarm output 3 is excitation (conduction). When the pre-alarm settings (common to AL1 to AL4) is ON, the light flashes during the delay times.	
		AL4 : Lights up when the relay for alarm output 4 is excitation (conduction). When the pre-alarm settings (common to AL1 to AL4) is ON, the light flashes during the delay times.	
Settings function	Functions for setting scaling values and operating values, and other settings.		
Switch function	Various settings can be configured using the settings switch.		
Contact delay function	This function performs a detection operation after exceeding the set operating value and after a contact delay period.		
Starting delay function	This function delays the start of detection until the specified starting delay time has elapsed after the power is turned on.		
Pre-alarm function	Function that causes the monitor lamp to flash during the contact delay period.		
Calibration function	Function for adjusting the input bias and span (for matching with connected equipment).		

Note⁽⁹⁾ Operating time C.D. + (N+1) × S + 50ms

C.D. : Contact delay time, N : Average count, S : Sampling period (100ms)

Note⁽¹⁰⁾ Release time (N+1) × S + 50ms

N : Average count, S : Sampling period (100ms)

Note⁽¹¹⁾ When the average count is 1.

Item	Specification	
Maximum value, minimum value	Function to display the maximum and minimum input values.	
Reset function	Function to reset the maximum and minimum values.	
Test function	Function that allows verifying alarm output operation without any input.	
Power interruption backup	Save each settings to non-volatile memory.	
Insulation resistance JIS C 1111	Between electrical circuit and case.	
	Between input/output terminals and power supply terminals.	
	Between input terminal and output terminal.	
	2 alarm outputs	Between AL1 output terminal and AL2 output terminal.
	3 alarm outputs	Between AL1 output terminal and AL2 output terminal and AL3 output terminal.
	4 alarm outputs	Between AL1 and AL2 output terminals and AL3 and AL4 output terminals.
Voltage test (Power-frequency withstand voltage) JIS C 1111	Between electrical circuit and case.	
	Between input/output terminals and power supply terminals.	
	Between input terminal and output terminal.	
	2 alarm outputs	Between AL1 output terminal and AL2 output terminal.
	3 alarm outputs	Between AL1 output terminal and AL2 output terminal and AL3 output terminal.
	4 alarm outputs	Between AL1 and AL2 output terminals and AL3 and AL4 output terminals
Impulse voltage test	Between electrical circuit and case.	5kV 1.2/50 μ s Both positive and negative polarity, for 3 times each.
Vibration	Apply vibration with a frequency of 16.7Hz and a peak-to-peak amplitude of 1mm in the X, Y, and Z directions for 10 minutes each no malfunction shall occur.	
Shock	Malfunction : Impact of 98m/s ² applied 3 times in each of the X, Y, and Z directions, both in the positive and negative directions. Durability : Impact of 294m/s ² applied 3 times in each of the X, Y, and Z directions, both in the positive and negative directions.	
Overload capacity	Voltage input	2 times 10 seconds, 1.5 times continuation of rated voltage.
	Current input	10 times 5 seconds, 1.5 times continuation of rated current.
	Power supply	1.5 times 10 seconds of rated voltage. Upper limit of the power supply voltage range (continuous).
Damped oscillatory wave immunity	Error within $\pm 10\%$ when peak voltage 2.5kV, frequency 1MHz $\pm 10\%$, applied 3 times for 30 seconds. Power supply (Normal / Common) Output (Common)	
Square impulse immunity test	Error within $\pm 10\%$ when noise (1 μ s, 100ns width) is repeatedly applied for 5 minutes. Power supply (Normal / Common) 1.0kV or more Output (Common) 1.0kV or more Input (Induction) 1.0kV or more	
Radio wave immunity	① Subject a transceiver with a rated output of 5W (150MHz, 400MHz) to intermittent radiation at a distance of 1m. Measurement error must be within 3%, and the device must not malfunction. ② Subject a mobile phone (800MHz, 1.8GHz) and a wireless LAN device (2.4GHz, 5GHz) to continuous radiation while in contact. Measurement error must be within 10%, and the devices must not malfunction.	

Item	Specification
Electrostatic discharge immunity	Measurement error must be within 10% and there must be no malfunctions, at contact discharge 8kV and air discharge 15kV. Capacitor charge system
Dimensions	50×80×133mm (W×H×D) (Including sockets)
Mass	Approx. 350g
Material	Case : ABS (V-0) Nameplate: Polyester film Socket : PBT Resin (Glass fiber containing)
Color	Case, Socket : Munsell N1.5 (Black), Nameplate : Gray
Operating temperature and humidity limits	-10 to +55°C, 5 to 90% RH (Non condensing)
Storage temperature limits	-25 to +70°C

12.3 Alarm output

(1) Specification

Item	Specification	
Output mode	The detection operation can be set to one of the following five modes. ① Upper limit set (H), Detection operation: Relay excitation ② Upper limit set (H), Detection operation: Relay non-excitation ③ Lower limit set (L), Detection operation: Relay excitation ④ Lower limit set (L), Detection operation: Relay non-excitation ⑤ OFF , Relay always non-excitation	
Relay excitation status indication	The monitor lamp illuminates when the relay is energized, and flashes during the delay period when the pre-alarm setting is ON (each contact).	
Relay and monitor lamp operation	Power supply OFF or relay non-excitation	Break contact (N.C.) : ON, Monitor Lamp : OFF
	Relay excitation	Break contact (N.C.) : OFF, Monitor Lamp : ON
	Output mode	Refer to (2) Operation of alarm output
Relay contact status	Refer to (2) Operation of alarm output	

(2) Operation of alarm output

Item		Specification				
Output mode		Relay and monitor lamp operation status				
		Operation value settings		Input →		
Relay and monitor lamp operation status	Excitation	H	Monitor Lamp	○	●	● : ON ○ : OFF
			Relay	Non-excitation	Excitation	
		L	Monitor Lamp	●	○	○
			Relay	Excitation	Non-excitation	
	Non-excitation	H	Monitor Lamp	●	○	○
			Relay	Excitation	Non-excitation	
		L	Monitor Lamp	○	●	●
			Relay	Non-excitation	Excitation	
OFF (Excitation, Non-excitation)		Monitor Lamp	○	○	○	
Relay	Non-excitation	Non-excitation				

Item		Specification	
Relay contact status	Contact configuration	4 alarm outputs Each make contact (N.O.)	4 alarm outputs Each break contact (N.C.)
	Power supply OFF or relay non-excitation		
	Relay excitation		
	Contact configuration	3 alarm outputs Each make contact (N.O.)	3 alarm outputs Each break contact (N.C.)
	Power supply OFF or relay non-excitation		
	Relay excitation		
	Contact configuration	2 alarm outputs Each change-over contact (N.O./N.C.)	
	Power supply OFF or relay non-excitation		
	Relay excitation		

(3) Relay operation

■ Contact delay function

Relay operation in over-input detection (Output mode : Excitation, H ⁽¹²⁾)

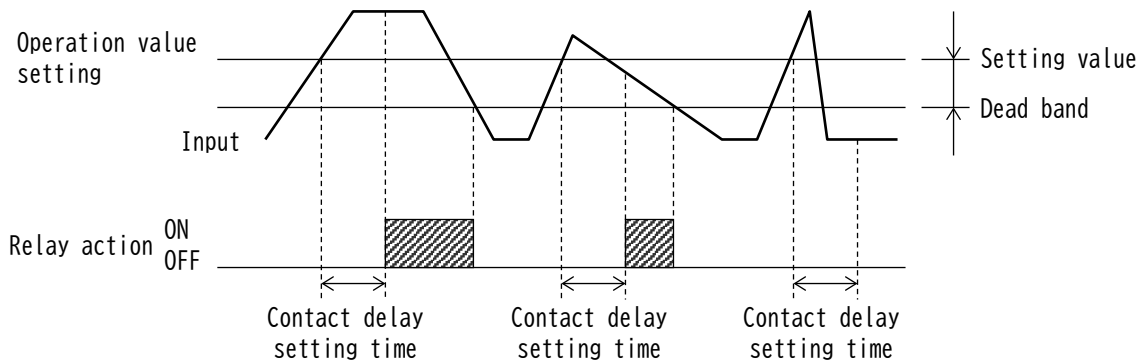

Relay operation in shortage input detection (Output mode : Excitation, L ⁽¹²⁾)

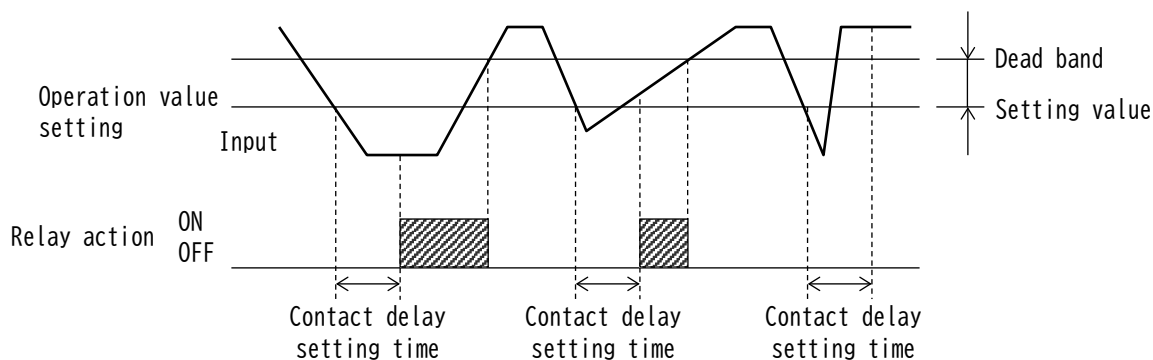

Note⁽¹²⁾ If the relay excitation setting is set to "non-excitation" the relay operation will be reversed.

■ Starting delay function

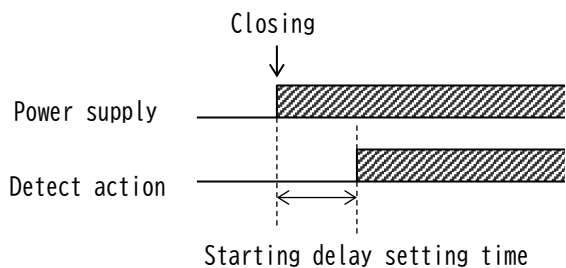

After an power supply applies, detect operation is performed after a starting delay time.

(4) Pre-alarm function

During the contact delay time between the detection of an operating value and the energization of the relay, the monitor lamp blinks, the blinking gradually becomes faster, and the lamp remains lit once the contact delay period has elapsed.

If the contact delay time is set to 0 seconds, the pre-alarm is disabled.

- Relay operation and pre-alarm in over-input detection.
(Output mode setting : Excitation H, Pre-alarm setting : ON)

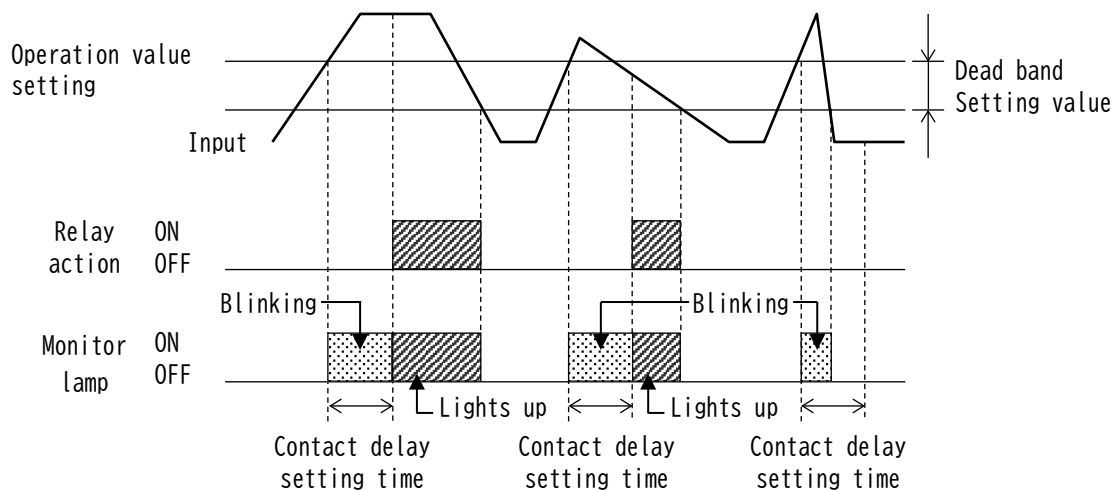

- Pre-alarm (blinking) operation during contact delay time.

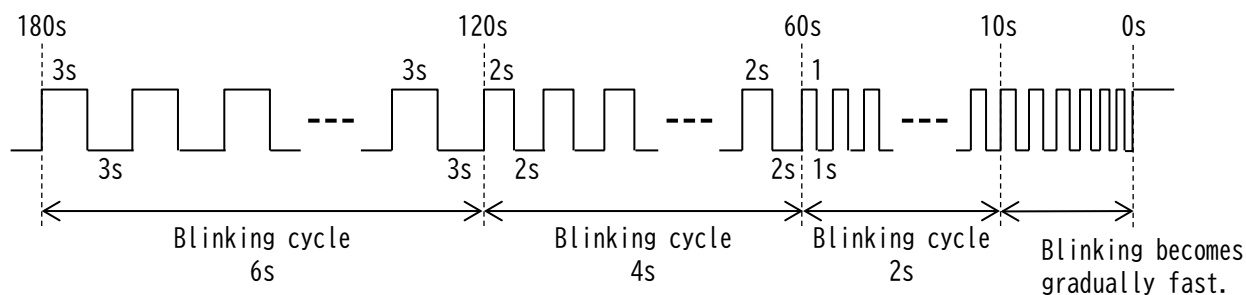

12.4 List of units

Item	Setting units							
Length	No. 1	No. 2	No. 3	No. 4	No. 5	No. 6		
	μm	mm	cm	m	$\times 10\text{mm}$	$\times 10\text{cm}$		
Mass	No. 7	No. 8	No. 9	No. 10	No. 11			
	mg	g	kg	t	$\times 10\text{kg}$			
Time	No. 12	No. 13						
	s	min						
Current	No. 14	No. 15	No. 16	No. 17	No. 18			
	mA	A	kA	μA	$\times 10\text{A}$			
Temperature	No. 19	No. 20	No. 21					
	K	$^{\circ}\text{C}$	$\times 10^{\circ}\text{C}$					
Angle	No. 22							
	$^{\circ}$							
Volume	No. 23	No. 24	No. 25	No. 26	No. 27	No. 28		
	m^3	mL	L	kL	$\times 10\text{L}$	$\times 100\text{L}$		
Speed	No. 29	No. 30	No. 31	No. 32	No. 33			
	m/s	mm/min	m/min	mm/h	m/h			
Acceleration	No. 34							
	m/s^2							
Frequency	No. 35							
	Hz							
Rotational speed	No. 36	No. 37	No. 38	No. 39				
	min^{-1}	s^{-1}	rpm	$\times 10\text{rpm}$				
Density	No. 40	No. 41						
	mg/L	g/L						
Force	No. 42	No. 43	No. 44					
	N	N · m	kN					
Pressure	No. 45	No. 46	No. 47	No. 48	No. 49	No. 50		
	Pa	hPa	kPa	MPa	PaG	$\times 10\text{kPa}$		
Mass flow rate	No. 51	No. 52	No. 53	No. 54	No. 55	No. 56	No. 57	No. 58
	kg/s	kg/min	t/min	mg/h	kg/h	t/h	$\times 10\text{kg/min}$	$\times 10\text{kg/h}$
Flow rate	No. 59	No. 60	No. 61	No. 62	No. 63	No. 64	No. 65	No. 66
	m^3/s	m^3/min	m^3/h	m^3/d	L/s	mL/min	L/min	L/h
	No. 67	No. 68	No. 69	No. 70	No. 71	No. 72	No. 73	
	kL/h	$\times 10\text{t/min}$	$\times 10\text{t/h}$	$\times 10\text{m}^3/\text{min}$	$\times 10\text{kL/h}$	$10^{-1}\text{m}^3/\text{s}$	$\times 10^2\text{m}^3/\text{h}$	
Normal flow rate ⁽¹³⁾	No. 74	No. 75	No. 76	No. 77	No. 78	No. 79	No. 80	No. 81
	m^3/s (normal)	m^3/min (normal)	m^3/h (normal)	m^3/d (normal)	L/s (normal)	mL/min (normal)	L/min (normal)	L/h (normal)
	No. 82							
	kL/h (normal)							
Heat	No. 83	No. 84	No. 85					
	J	KJ	MJ					
Voltage	No. 86	No. 87	No. 88					
	mV	V	kV					
Electrical resistance	No. 89	No. 90	No. 91					
	Ω	k Ω	M Ω					
Conductance	No. 92	No. 93						
	μS	S						
Power	No. 94	No. 95	No. 96	No. 97	No. 98	No. 99		
	W	kW	MW	mW	$\times 10\text{kW}$	$\times 10\text{MW}$		

Note⁽¹³⁾ The units of normal flow rate are displayed on a single line.

Item	Setting units							
	Electric energy	No. 100 W · h	No. 101 kWh	No. 102 ×10kWh				
Reactive power	No. 103 var	No. 104 kvar	No. 105 Mvar	No. 106 ×10Mvar				
Electrical conductivity	No. 107 μS/cm	No. 108 S/m						
Concentration	No. 109 %	No. 110 %RH	No. 111 ppb	No. 112 ppm	No. 113 pH	No. 114 ×10ppb	No. 115 ×10ppm	
Reference surface	No. 116 APm	No. 117 OPm	No. 118 SPm	No. 119 TPm	No. 120 YPm	No. 121 DLm	No. 122 ELm	No. 123 ×10TPm
Other	No. 124 cos φ	No. 125 cos θ	No. 126 LAG	No. 127 LEAD	No. 128 φ			
No units (¹⁴)	No. 129 (NONE)							

Note(¹⁴) If you select “No units,” the units will not be displayed.

13 Inspection and calibration

13.1 Inspection

No special daily inspection is required, but please pay attention to the following on a regular basis.

- (1) Check that the connection between the main unit and the socket is secure (that the lock is fully engaged).
- (2) Check for loose wiring or mounting screws.
- (3) Please remove any dust from the case.

13.2 Calibration

Please perform the calibration using the calibration circuit shown in the figure on the right.

- (1) After turning on the power, allow the instrument to warm up for 15 minutes.
- (2) Set the CBIAS value so that the display shows the minimum reading when an input corresponding to the minimum display is applied. Next, set the CSPAN value so that the display shows the maximum reading when an input corresponding to the maximum display is applied. Verify the above settings again. If the readings are correct, calibration is complete. For details on setting the CBIAS and CSPAN values, refer to Section 8. Settings change mode.
- (3) Please check the operating values, return values, and dead band.

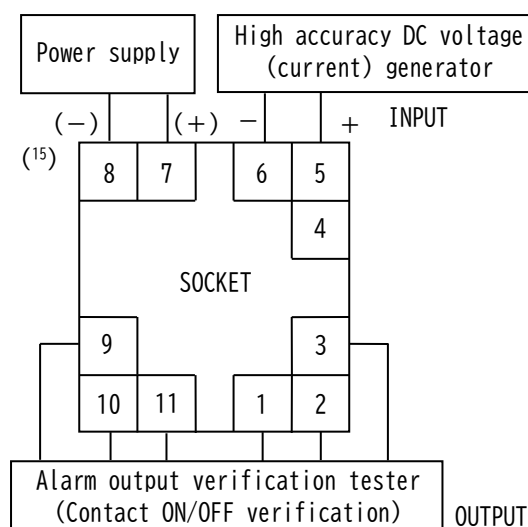

Note(¹⁵) The polarity shown in () is for DC power supplies.

14 Troubleshooting

Symptom	Possible Cause	Action	
Power LED is not lit	No power supply is applied to terminals 7 and 8	Apply power supply	
Display is off	Due to the auto-off function	Press the switch	
Display error (large)	Power supply voltage is out of range	Check the power supply voltage	
	Input error	Check the input value	
	Incorrect scaling settings	Check the scaling settings	
Display error (small)	Aging of the input	Please calibrate the display (See Section 13.2 of the Instruction Manual)	
No alarm output	No power supply applied to terminals 7 and 8	Apply power supply	
	Power supply voltage is low	Check the power supply voltage	
	Input wiring is incorrect	Check the input wiring	
	Input is abnormal	Check the input value	
	Incorrect scaling settings	Check the scaling settings	
	Incorrect output wiring	Check the output wiring	
Alarm output does not reset	Deadband is too large	Check the deadband settings	
Error displayed	ROM ERROR	SUM value error	Replace the unit
	RAM ERROR	READ/WRITE error	
	EEP ERROR	Stored value error	
	A/D ERROR	A/D conversion error	

 **DAIICHI ELECTRONICS CO., LTD.**

Tokyo Office : 11-13, Hitotsuya 1-chome, Adachi-ku, Tokyo, 121-8639, JAPAN.
TEL : +81-3-3885-2411 , FAX : +81-3-3858-3966

Kyoto Office : 1-19, Ichinobe-Nishikawahara, Jyoyou-shi, Kyoto, 610-0114, JAPAN.
TEL : +81-774-55-1391 , FAX : +81-774-54-1353

Revision A, DATE : June 11, 2026