

INSTRUCTION MANUAL (DETAILED VERSION)

MULTI-TRANSDUCER

QT2-500



Contents

Introduction	2
Safety precaution	2
Composition of type	3
1 Features of product	4
2 Dimensions and part names	4
3 Bundled items	4
4 Installation instructions	4
5 Connection	6
6 Operation · Screen	8
6.1 Basic operation	8
6.2 Screen structure	8
7 Display mode	8
7.1 Measurement display	8
7.2 Setting value display	10
8 Setting mode	11
8.1 Setting flow	11
8.2 Setting method	11
8.3 Setting menu	12
9 Test mode	22
9.1 Test flow	22
9.2 Test menu	22
10 Specifications	23
10.1 Rating	23
10.2 Measurement item, Class	24
10.3 Detailed specification	25
10.4 Measuring range	29
10.5 Input - output characteristic example	31
11 Multi-transducer setting software (QT2-CS-01)	35
11.1 Outline	35
11.2 Operating environment	35
11.3 System configuration	35
12 Troubleshooting	36

Introduction

Thank you for purchase of DAIICHI product.
Please read this instruction manual carefully before use.
Keep this manual for future reference.
Please contact with us in case this manual is lost or damaged.

Safety Precaution

■ Environment conditions

- Please be sure to use this product in a place that meets the following conditions. In places that do not meet this condition, malfunctions and failures, and performance and product life may be reduced.
 - ① Within the range of ambient temperature $-10...55\text{ }^{\circ}\text{C}$, humidity $5...90\text{ \% RH}$.
 - ② Place free of corrosive gas. (Corrosive gas: SO_2 / H_2S , etc.)
 - ③ Place free of dust, salt and oily smoke.
 - ④ Location that is not affected by vibration and shock.
 - ⑤ Location that is not affected by external noise.
 - ⑥ Altitude 2000m or less.
- If the input to this product is an inverter output such as cycle control, SCR phase angle control and PWM control, measurement error may increase.

■ Outdoor use conditions.

- ① These products are not a dustproof, waterproof, and splash proof construction. Please avoid the place with much dust. Please do not install in the place directly exposed to the rain and water droplets. (IP code: IP30)
- ② Please do not install in the place directly exposed to the sun even through the glass. Discoloration and degradation of a name plate, and deformation of the box by the surface temperature rise may cause.
- ③ Product life may shorten when the daily average temperature exceeds $40\text{ }^{\circ}\text{C}$.

■ Mounting and wiring

Please refer to this instruction manual for installation and the wiring.



- Please refer to connection diagram for the wiring.
An improper connection may cause generation of high voltage on the CT secondary side, and which may lead to device malfunction, burning or fire.
- Hot line work is prohibited. There is a risk of explosion by electric shock, device malfunction, burning, fire, or gas.
- Please use an electrical wire size suitable with the rated current.
Use unsuitable size electric wire, which may lead to a fire.
- Please check the tightening of the screw. If the screws are loose, it may cause a fire or malfunction.
- The terminal cover is installed for preventing an electric shock accident.
Please close terminal cover after wiring work.

■ Preparation

This product must be set before use. Please read this manual and make the setting correctly.
If you make a mistake on the setting it does not operate correctly.

■ Maintenance and inspection

- ① Inspection during energization is dangerous.
- ② No replacement in periodic inspection.
- ③ Please wipe off lightly with the dry soft cloth.
- ④ Please do not use the organic solvent, chemicals, cleaners, etc., such as an alcohol, for cleaning.

■ Storage

When storing this product for a long period, please keep it in a place that satisfies the following environmental conditions.

- Within the range of ambient temperature ($-20...70\text{ }^{\circ}\text{C}$) and humidity ($5...90\text{ \%RH}$).
- Place where average daily temperature does not exceed $40\text{ }^{\circ}\text{C}$.
- Locations with little dust, corrosive gases, salt and oil smoke.
- A place not subject to vibration or shock.

■ Countermeasures against troubles

If this product breaks down within the warranty period, it will be repaired by DAIICHI Electronics.

■ Disposal

Please dispose of this product as industrial waste (noncombustible).
Mercury parts and a nickel-cadmium battery are not used for this product.

■ Warranty period

The warranty period of the product is one year after the date of delivery.

■ Warranty scope

In the state of the normal use of product-specification within the range according to this instruction manual, the trouble within the warranty period performs exchange or repair gratuitously.

However, if it corresponds to the next, it does not warrant.

- ① If it breaks down when converted or repaired except our company.
- ② If it breaks down by use out of specification range.
- ③ If the cause of trouble is based on cause other than this product.
- ④ Transportation, movement, damage by falling, and trouble.
- ⑤ Other, natural disasters, disasters, etc. In the case where the supplier side (Company and agent) is not responsible.

This warranty is a guarantee for the delivered product. Cannot warrant the damage induced by trouble of this product.

■ Replacement cycle of the product

We recommend updating the product for 10 years as a rough standard.

■ Change of instruction manual written contents.

This instruction manual changes written contents without a notice by product improvement etc.

Composition of type

Type	Specification code			
QT2-500-	① Auxiliary supply		② Analog output	
	1	80...264 V AC, DC AC/DC common use	1	0...5 V DC (600 Ω...∞) A 0...1 mA DC (0...10 kΩ)
	2	20...57 V DC	2	0...10 V DC (2 kΩ...∞) B 4...20 mA DC (0...550 Ω)
			3	1...5 V DC (600 Ω...∞) C -1...1 mA DC (0...10 kΩ)
		4	-5...5 V DC (600 Ω...∞) Z Other (special specification)	

1. Features of product

- Compliant with IEC60688 : 2012 (Transducer)、IEC62053 : 2003 (Static meters for active energy, Static meters for reactive energy).
- CE marking product
- Possible to change by setting. (Wiring type, rated voltage, rated current)
- Standard equipment. 10-analog output, 2-pulse output, RS-485 Communication output (MODBUS / Protocol A).
- Connected to a PC with USB, you can write and read settings in dedicated software.
About the setting software, it is more downloadable than our web site.
URL ; <http://www.daiichi-ele.co.jp/en/>
- Using an organic electro-luminescence display of high contrast.
Configuration changes, measurement items can be displayed.
- Wiring after installation can be confirmed in the test output by the front operation. To display the phase angle between the voltage and current, and supports the determination of the wiring mistake points.

2. Dimensions and part names

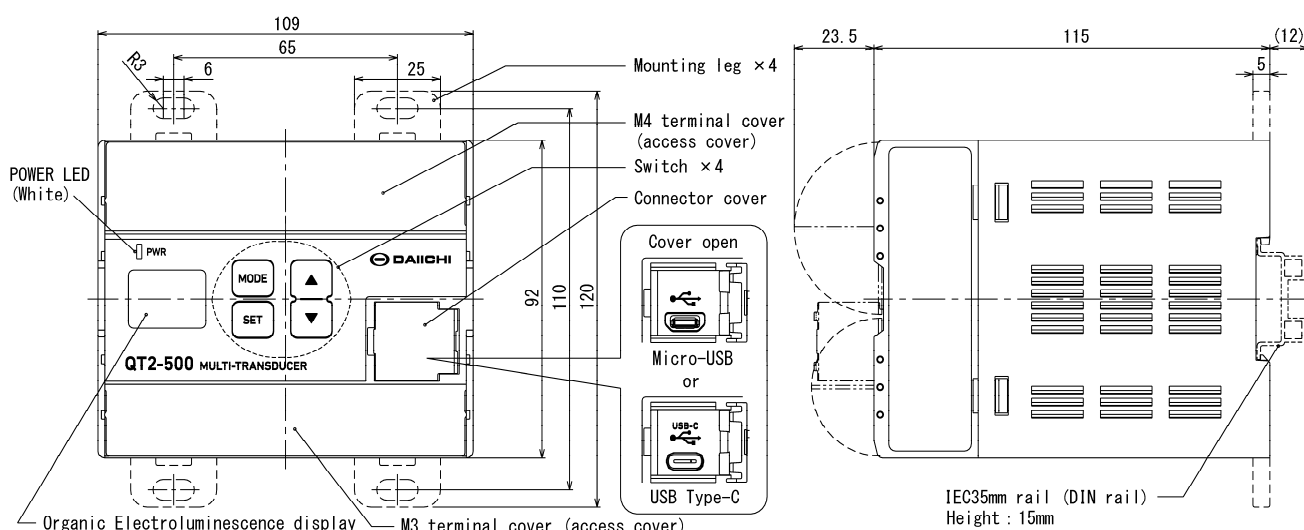

3. Bundled items

- ① Instruction Manual (Instruction·Operation) 1
- ② Attachment tool 4
- ③ Termination resistor for communication (100Ω) 1

4. Installation instructions

Please select indoors without low mechanical vibration, dust, and corrosive gas.
There is no limit of a mounting position.
Mounting instruction can select IEC 35 mm rail (DIN rail) mounting and screw mounting.
Please separate the mounting side-by-side interval by 10 mm or more as a measure against heat.
Please consider heat and separate more than 10 mm of the interval of mounting side by side.
Please consider heat and wiring space and separate more than 90 mm of the space above and below.
Please secure the space distance of a terminal and a metal panel 10 mm or more.

<Caution> Please do installation of a product and removal after a power supply and an input signal are stopped.

■ Mounting the IEC 35 mm rail (DIN rail)

Set product so that its slider is at the bottom. Position the upper hook at the rear side of product on the DIN rail and push in the lower.

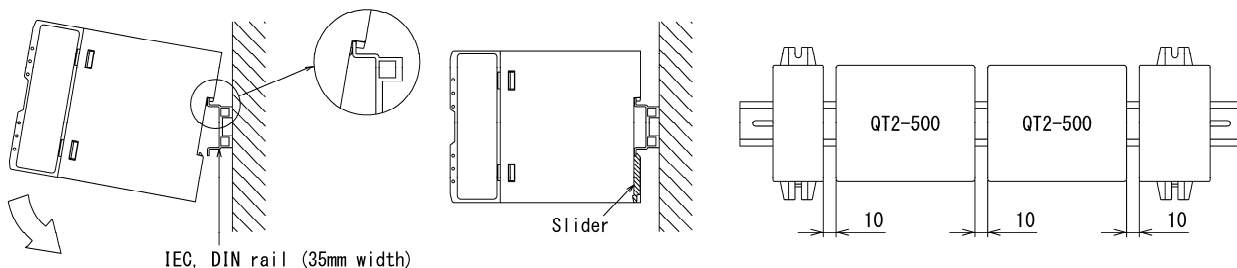

■ Removal from IEC 35 mm rail (DIN rail)

Insert a flat-blade screwdriver into the square holes of the sliders (2 places). While pulling out the two sliders in the direction of ① at the same time, pull up the product in the direction of ②. The product can be removed from the rail by simply pulling out the slider 1.5 mm.

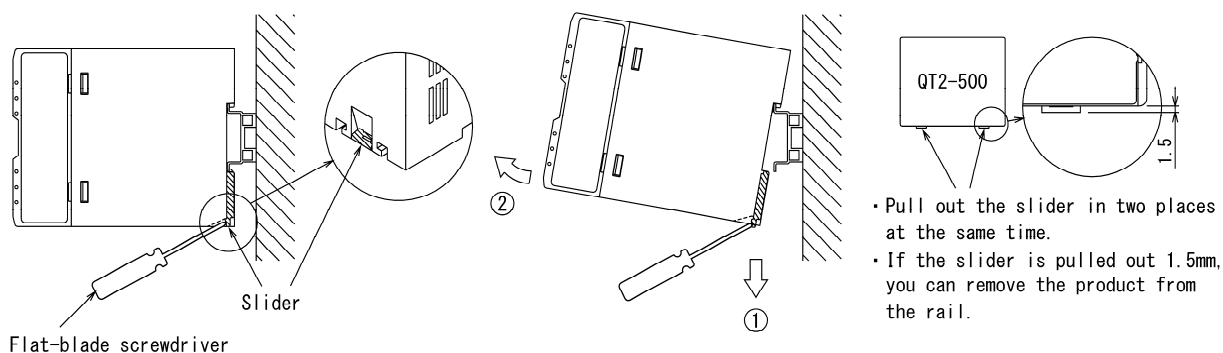

<Caution>

If you pull out the slider by moving the screwdriver like a lever, or pull up the product without pulling out the slider, the product may be damaged.

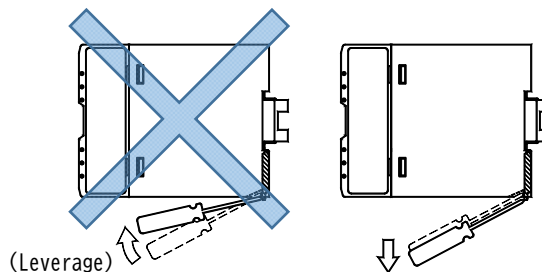

■ Screw mounting

Attach the included mounting leg (×4). Please install with M4 screw or M5 screw. Tightening torque, M4 : 1.00...1.30 N·m Tightening torque, M5 : 2.00...2.50 N·m

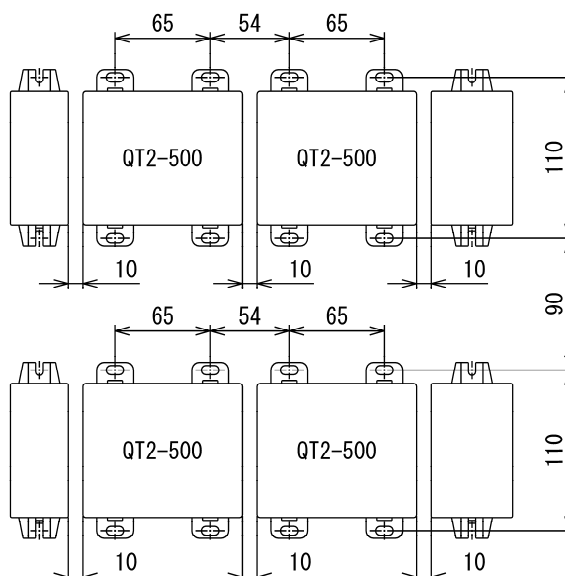
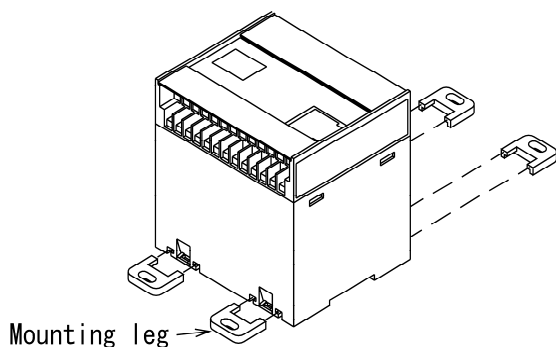

<Caution> Please mount a product from the bottom to prevent a fall.

5. Connection

Open the terminal cover, please connections according to the wiring diagram below.
Terminal numbers and names are listed on the back of the terminal cover.

<Caution>

When opening or closing the terminal cover, hold the edge area of the cover and operate it without applying excessive force.

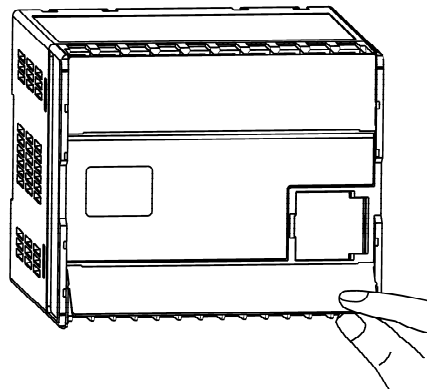

- Upside terminal No.1...15
Auxiliary supply, Voltage, Current, Binary input, Ground terminal
Screw : M4 screw
Conformity crimp-type terminal
: Crimp-type terminal for M4 screw.
Outside diameter for terminal : 8.5 mm or less
Tightening torque : 1.0...1.3 N·m

- Downside terminal No.16...42
Analog output, Pulse output, Communication output terminal
Screw : M3 screw
Conformity crimp-type terminal
: Crimp-type terminal for M3 screw.
Outside diameter for terminal : 6 mm or less
Tightening torque : 0.5...0.6 N·m

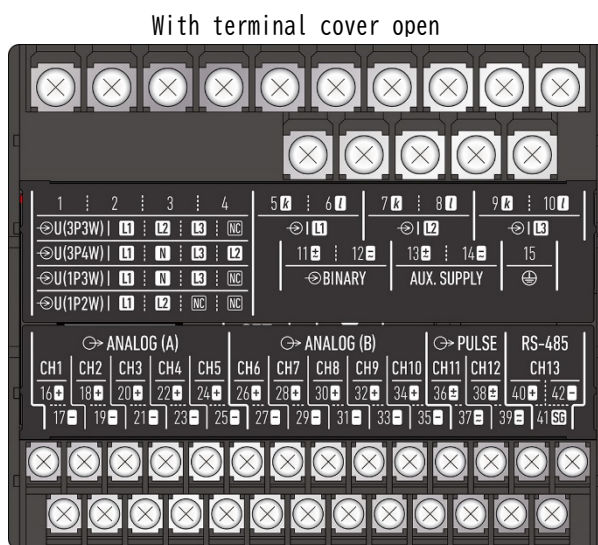

■ 3P3W [3-phase 3-wire] (2VT2CT)

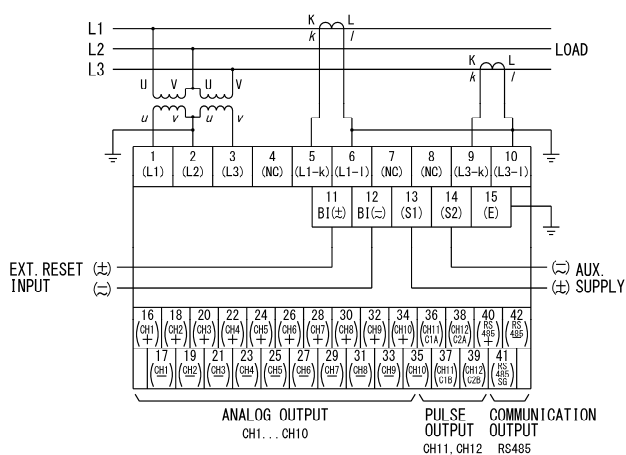

■ 3P4W [3-phase 4-wire] (3VT3CT)

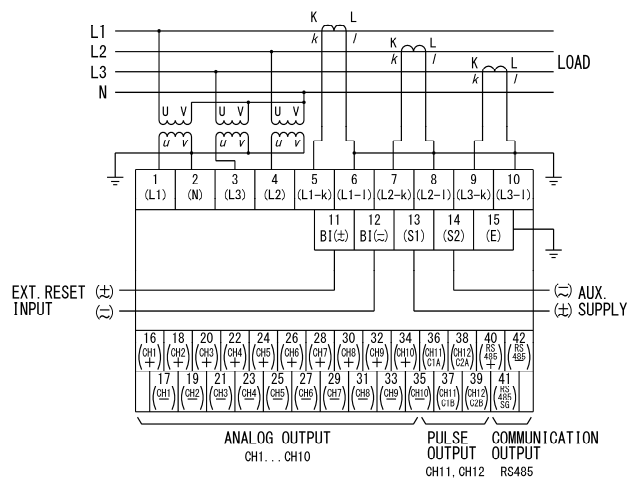

■ 3P3W [3-phase 3-wire] (2VT3CT)

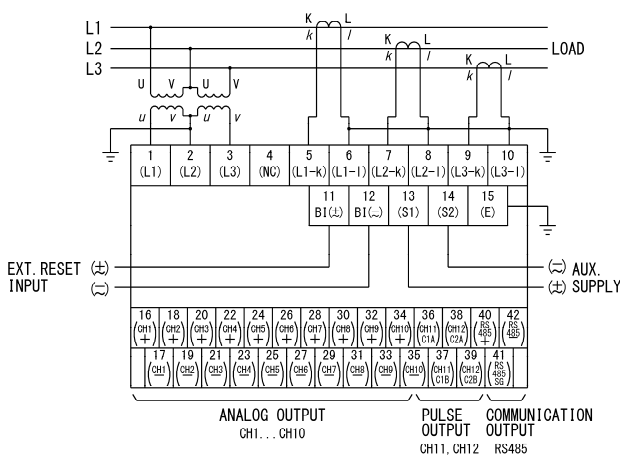

■ 3P4W [3-phase 4-wire] (2VT3CT)

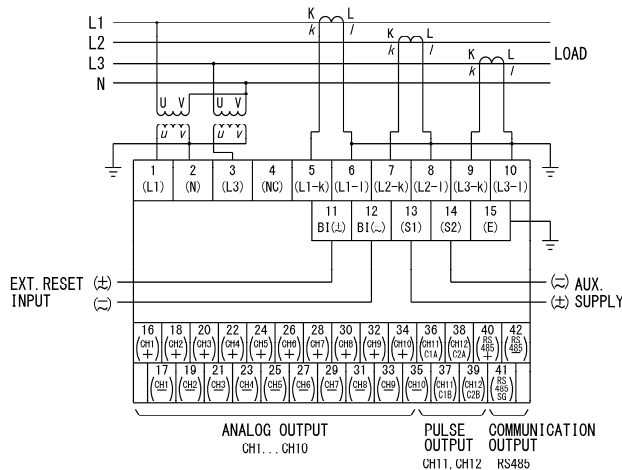

■ 1P2W [1-phase 2-wire]

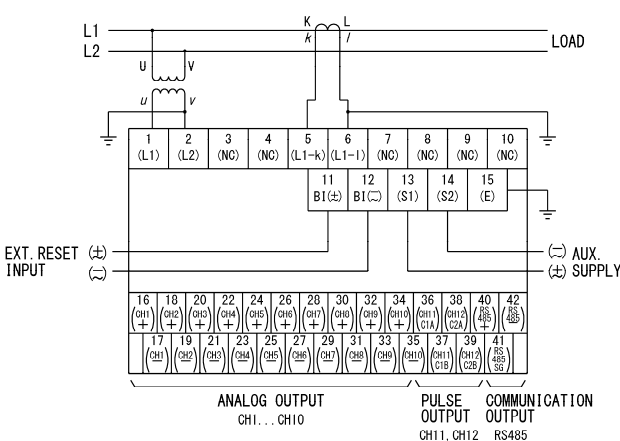

■ 1P3W [1-phase 3-wire]

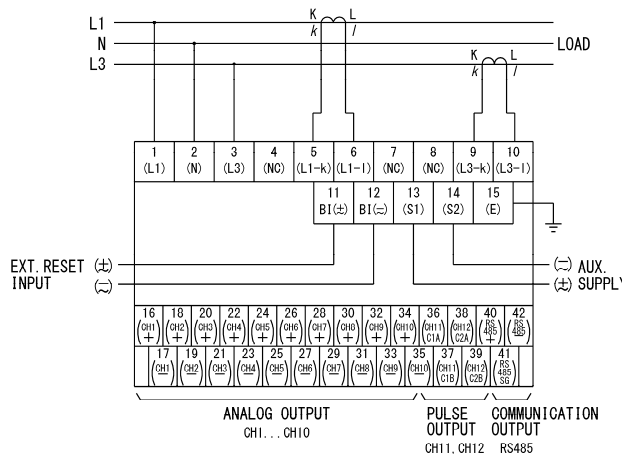

• Maximum rated voltage

Wiring type	3P4W	3P3W (Ground)	3P3W (Ungrounded)	1P2W (Ground)	1P2W (Ungrounded)	1P3W
Maximum rated voltage	277 V (L-N) 480 V (L-L)	220 V (L-L)	480 V (L-L)	220 V (L-L)	480 V (L-L)	220 V (L-N) 440 V (L-L)

- In the case of the low-pressure circuit (600 V or less), the secondary grounding of VT / CT is not required.
- Ground terminal (No.15), please be sure to ground. Ground is a class D grounding (grounding resistance less than 100 Ω).
- When using with three-phase four-wire (2VT3CT), voltage balance is a condition.
- Output wiring and the noise source (power line, steep voltage, the wire there is a current fluctuation), please release as much as possible. Please use a twisted cable or twisted cable shielded.
- Minus (-) terminals are connected internally of analog output CH1...5. (Common, Non-isolated)
Minus (-) terminals are connected internally of analog output CH6...10. (Common, Non-isolated)
- Be used open the analog output terminal (current output), there is no damage to this product.
- Termination resistor for the communication output, please use at the end of equipment. Please connect the termination resistor between the RS485 of (+)(-) terminals.
- By applying a voltage signal (auxiliary supply and the same rating) to the external reset input, maximum demand value (current and power) can be reset.
- After the wiring work, please close the terminal cover.

6. Operation and Screen

6.1 Basic operation

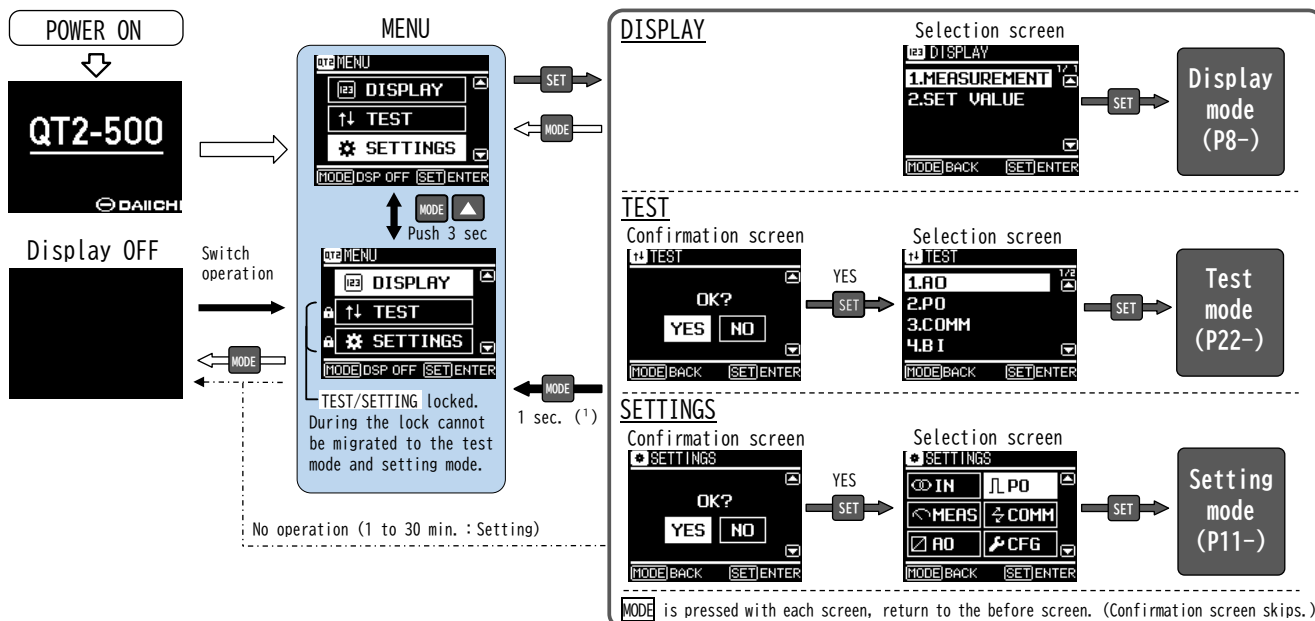

Note (1) By pressing and holding the switch for more than one second, it returns from each of the screen to the MENU screen.

6.2 Screen structure

• Screen display

- Display name
- Main display
Display the item, settings, measurement etc..
- Lock icon
Displays at the time of the test / setting lock.
- Cursor position (highlight)
- USB icon
To display when the USB connection.
- Switch icon
Displayed when the ▲ and ▼ of the operation is required.
- Operation guidance
Display the operation at the time of switch operation.

7. Display modes

7.1 Measurement display

(1) Display

- Measurands
- Phase / line display
- Page No.
Current page / Total pages
- Measurement value
Input is converted into the %.
Example : 110 V, 5 A

I, HI	0... 5 A	0... 100.0 %
U, HU	0... 150 V	0... 100.0 %
P/Q/S	-1 kW/kvar... 1 kW/kvar/kVA	-100.0~100.0 %

Power factor, frequency, active energy, harmonics distortion / content display a real measured value. Refer to section 10.4 for details.

(2) Operation

- ① 【MENU】 → 「DISPLAY」 [SET] → 「MEASUREMENT」 [SET] → Measurement display mode.
- ② Select the measurement element to be displayed. (▲ ▼ switch)

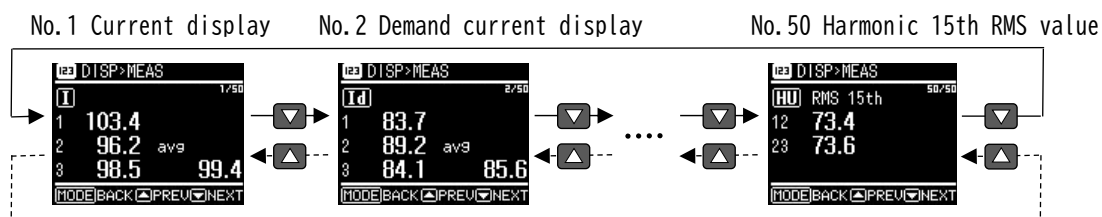

(3) Measurement item

Page	Measurement	Screen display	Wiring type			
			3P3W	3P4W	1P2W	1P3W
1	Current, Current (power flow)	I	1, 2, 3, avg ⁽²⁾	1, 2, 3, N, avg ⁽²⁾	I	1, 3, N
2	Demand current	Id	1, 2, 3, avg ⁽²⁾	1, 2, 3, N, avg ⁽²⁾	Id	1, 3, N
3	Maximum demand current	Idmax	1, 2, 3, avg ⁽²⁾	1, 2, 3, N, avg ⁽²⁾	Idmax	1, 3, N
4	Line voltage, Phase voltage	U	12, 23, 31, avg ⁽²⁾	12, 23, 31, LLavg, 1N, 2N, 3N, LNavg ⁽³⁾	U	13, 1N, 3N
5	Active power	P	Σ ⁽²⁾	1, 2, 3, Σ ⁽²⁾	P	Σ ⁽²⁾
6	Demand power	Pd	Σ ⁽²⁾	1, 2, 3, Σ ⁽²⁾	Pd	Σ ⁽²⁾
7	Maximum demand power	Pdmax	Σ ⁽²⁾	1, 2, 3, Σ ⁽²⁾	Pdmax	Σ ⁽²⁾
8	Reactive power	Q	Σ ⁽²⁾	1, 2, 3, Σ ⁽²⁾	Q	Σ ⁽²⁾
9	Apparent power	S	Σ ⁽²⁾	1, 2, 3, Σ ⁽²⁾	S	Σ ⁽²⁾
10	Power factor	PF	Σ ⁽²⁾	1, 2, 3, Σ ⁽²⁾	PF	Σ ⁽²⁾
11	Frequency	f	f	f	f	f
12	Active energy	Wh	Incoming (+) / Outgoing (-)			
13	Reactive energy (Incoming)	+varh	LAG/LEAD			
14	Reactive energy (Outgoing)	-varh	LAG/LEAD			

Page	Measurement		Measurands		Wiring type			
					3P3W	3P4W	1P2W	1P3W
15	Harmonic current	Distortion factor	HI	THD	2VT, 2CT 1, 3	1, 2, 3	HI	1, 3
16		5th conversion content		CONV. 5th				
17...23		3th, 5th, 7th, 9th, 11th, 13th, 15th, content		3th, 5th, 7th, 9th, 11th, 13th, 15th				
24		5th conversion RMS value		CONV. 5th				
25		Fundamental-wave RMS value		1st				
26...32		3th, 5th, 7th, 9th, 11th, 13th, 15th, RMS value		3th, 5th, 7th, 9th, 11th, 13th, 15th				
33	Harmonic voltage	Distortion factor	HU	THD	12, 23	2VT, 3CT 1N, 3N	HU	1N, 3N
34		5th conversion content		CONV. 5th				
35...41		3th, 5th, 7th, 9th, 11th, 13th, 15th, content		3th, 5th, 7th, 9th, 11th, 13th, 15th				
42		5th conversion RMS value		CONV. 5th				
43		Fundamental-wave RMS value		1st				
44...50		3th, 5th, 7th, 9th, 11th, 13th, 15th, RMS value		3th, 5th, 7th, 9th, 11th, 13th, 15th				

Note ⁽²⁾ avg : Average, Σ : Total.

Note ⁽³⁾ Since the line voltage and phase voltage that is displayed on the 2 page, the following pages No. will be +1. (3P4W)

7.2 Setting value display

(1) Display

Example : Analog output settings



- Page No.
Number of pages / Total number of pages
- Setting value
Display the set value of the right table.

Page	Setting item	Display	Setting contents
1	Input	Top	Wiring type
		Center	VT ratio
		Bottom	CT ratio
2...11	Analog output	Top	CH No. Output factor
		Bottom	Input range for output value
12 13	Pulse output	Top	CH No. Output factor
		Bottom	Output pulse rate
14	Communication output	Top	CH No. Protocol
		Center	Address
		Bottom	Bit rate

(2) Operation

- ① 【MENU】 → 「DISPLAY」 **SET** → 「SET VALUE」 **SET** → Measurement display mode.
- ② Select the setting value to be displayed. (**▲** **▼** switch)

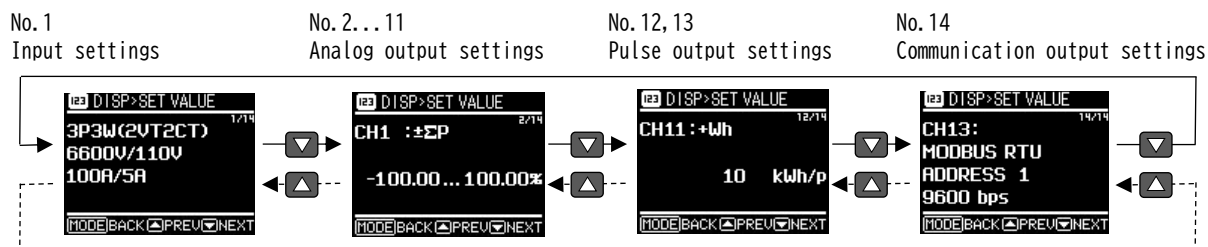

8. Setting modes

8.1 Setting flow

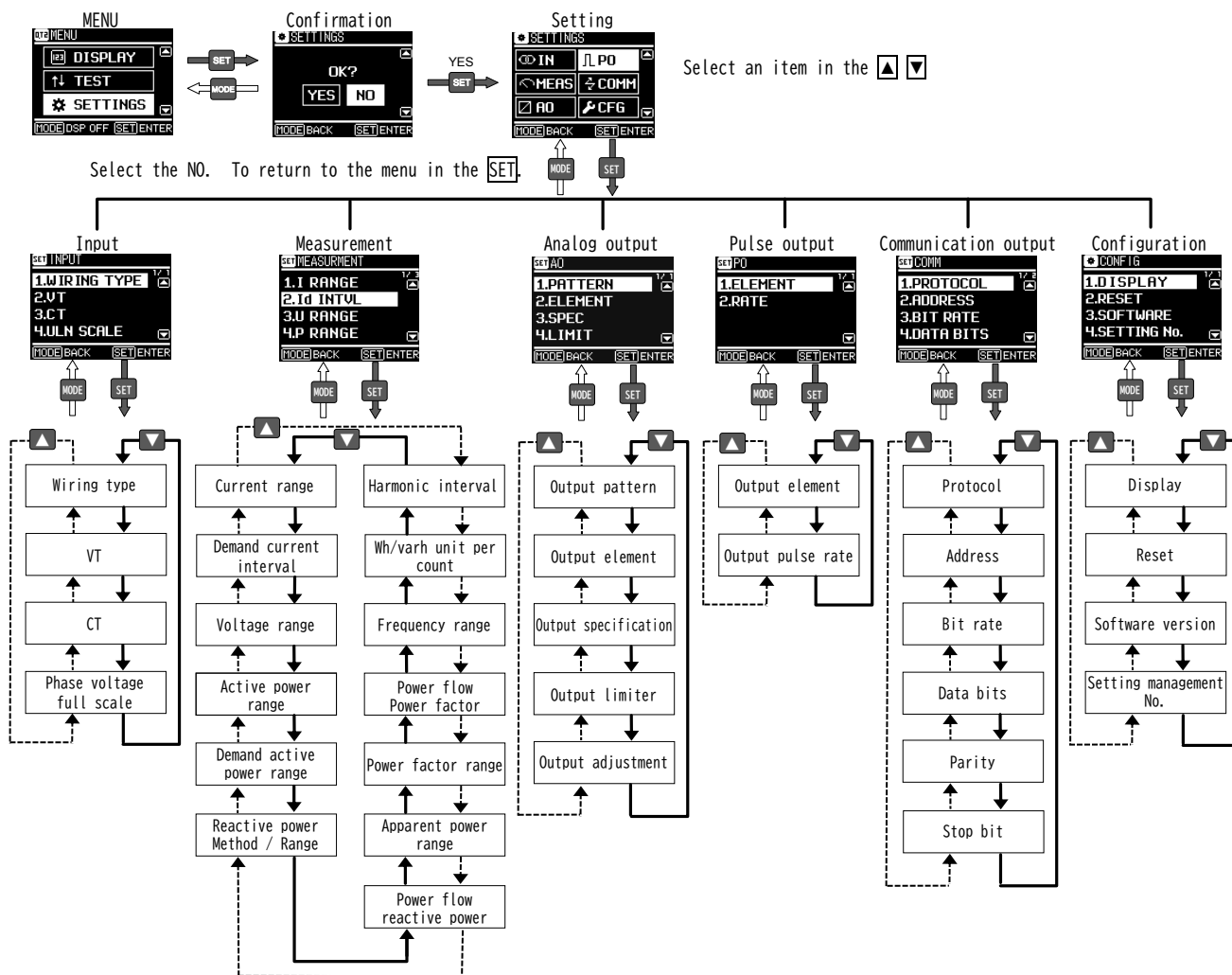

8.2 Setting method

(1) Display

Example: Wiring type setting

- Setting item
- Setting value (✓)
- Setting cursor Move by ▲▼
- With the next hierarchies

Example: Current range setting

- Page No. Current page / Total page
- Switch icon Operate the ▲▼.
- Setting value ▲▼ in the increase or decrease.
- Operation guidance Display the operation at the time of switch operation

(2) Operation

- ① Each setting display → Setting change of **▲** **▼** → Push **SET** (When indicating **SET** +, SET is pushed for more than 1 second.) → Enter
- ② When the setting is confirmed, to display the "✓" indicating the current setting in place of the changed setting value.
- ③ When **▲** **▼** is pushed lengthily, the set value changes at high speed.

8.3 Setting menu

(1) Input setting IN

Setting item	Description	Content																																																																						
Wiring type 【WIRING TYPE】	Set wiring type of input circuit. 3P3W sets up the number of CT. 3P4W sets up the number of CT, and the number of VT.	<div style="display: flex; justify-content: space-around;"> <div style="border: 1px solid black; padding: 2px;"> <p>【Wiring type】</p> </div> <div style="border: 1px solid black; padding: 2px;"> <p>【Number of CT】</p> </div> </div> <p><Cautions> If this setup is performed, all set points will be initialized. Please set up first.</p> <table border="1" style="width: 100%; border-collapse: collapse;"> <thead> <tr> <th colspan="3">Thick-frame : Default setting</th> </tr> <tr> <th colspan="3">Setting range</th> </tr> </thead> <tbody> <tr> <td>3-phase 3-wire</td> <td>3P3W</td> <td>2VT, 2CT 2VT, 3CT</td> </tr> <tr> <td>3-phase 4-wire</td> <td>3P4W</td> <td>2VT, 3CT 3VT, 3CT</td> </tr> <tr> <td>1-phase 2-Wire</td> <td colspan="2">1P2W</td> </tr> <tr> <td>1-phase 3-wire</td> <td colspan="2">1P3W</td> </tr> </tbody> </table>	Thick-frame : Default setting			Setting range			3-phase 3-wire	3P3W	2VT, 2CT 2VT, 3CT	3-phase 4-wire	3P4W	2VT, 3CT 3VT, 3CT	1-phase 2-Wire	1P2W		1-phase 3-wire	1P3W																																																					
Thick-frame : Default setting																																																																								
Setting range																																																																								
3-phase 3-wire	3P3W	2VT, 2CT 2VT, 3CT																																																																						
3-phase 4-wire	3P4W	2VT, 3CT 3VT, 3CT																																																																						
1-phase 2-Wire	1P2W																																																																							
1-phase 3-wire	1P3W																																																																							
VT 【VT】	Set in accordance with the use VT. Primary voltage - PRIMARY, Secondary voltage - SECONDARY	<div style="display: flex; justify-content: space-around;"> <div style="border: 1px solid black; padding: 2px;"> <p>【VT select】</p> </div> <div style="border: 1px solid black; padding: 2px;"> <p>【Primary voltage】</p> </div> </div> <p>Default setting 3P3W : 6600 V/110 V 3P4W : 440 V/440 V (Direct) 1P2W : 3300 V/110 V 1P3W : 110 V/110 V (Direct)</p> <p><Cautions> In direct connection, please set a primary voltage and a secondary voltage as the same value.</p> <table border="1" style="width: 100%; border-collapse: collapse;"> <thead> <tr> <th colspan="4">Setting range</th> </tr> <tr> <th colspan="2">Primary voltage</th> <th colspan="2">Secondary voltage</th> </tr> </thead> <tbody> <tr><td>110 V</td><td>6600 V</td><td>66 kV</td><td>110 V</td></tr> <tr><td>220 V</td><td>11 kV</td><td>77 kV</td><td>220 V</td></tr> <tr><td>440 V</td><td>13.2 kV</td><td>110 kV</td><td>440 V</td></tr> <tr><td>880 V</td><td>13.8 kV</td><td>132 kV</td><td>—</td></tr> <tr><td>1100 V</td><td>16.5 kV</td><td>154 kV</td><td>—</td></tr> <tr><td>1650 V</td><td>18.4 kV</td><td>187 kV</td><td>—</td></tr> <tr><td>2200 V</td><td>22 kV</td><td>220 kV</td><td>—</td></tr> <tr><td>3300 V</td><td>33 kV</td><td>—</td><td>—</td></tr> </tbody> </table>	Setting range				Primary voltage		Secondary voltage		110 V	6600 V	66 kV	110 V	220 V	11 kV	77 kV	220 V	440 V	13.2 kV	110 kV	440 V	880 V	13.8 kV	132 kV	—	1100 V	16.5 kV	154 kV	—	1650 V	18.4 kV	187 kV	—	2200 V	22 kV	220 kV	—	3300 V	33 kV	—	—																														
Setting range																																																																								
Primary voltage		Secondary voltage																																																																						
110 V	6600 V	66 kV	110 V																																																																					
220 V	11 kV	77 kV	220 V																																																																					
440 V	13.2 kV	110 kV	440 V																																																																					
880 V	13.8 kV	132 kV	—																																																																					
1100 V	16.5 kV	154 kV	—																																																																					
1650 V	18.4 kV	187 kV	—																																																																					
2200 V	22 kV	220 kV	—																																																																					
3300 V	33 kV	—	—																																																																					
CT 【CT】	Set in accordance with the use CT. Primary current - PRIMARY, Secondary current - SECONDARY	<div style="display: flex; justify-content: space-around;"> <div style="border: 1px solid black; padding: 2px;"> <p>【Primary/Secondary】</p> </div> <div style="border: 1px solid black; padding: 2px;"> <p>【Primary current】</p> </div> </div> <p>Default setting 3P3W : 100 A/5A 3P4W : 1500 A/5 A 1P2W : 50 A/5 A 1P3W : 500 A/5 A</p> <table border="1" style="width: 100%; border-collapse: collapse;"> <thead> <tr> <th colspan="5">Setting range</th> </tr> <tr> <th colspan="4">Primary current</th> <th>Secondary current</th> </tr> </thead> <tbody> <tr><td>5 A</td><td>60 A</td><td>750 A</td><td>5000 A</td><td>5 A</td></tr> <tr><td>6 A</td><td>75 A</td><td>800 A</td><td>6000 A</td><td>1 A</td></tr> <tr><td>7.5 A</td><td>80 A</td><td>900 A</td><td>7500 A</td><td>—</td></tr> <tr><td>8 A</td><td>100 A</td><td>1000 A</td><td>8000 A</td><td>—</td></tr> <tr><td>10 A</td><td>120 A</td><td>1200 A</td><td>9000 A</td><td>—</td></tr> <tr><td>12 A</td><td>150 A</td><td>1500 A</td><td>10 kA</td><td>—</td></tr> <tr><td>15 A</td><td>200 A</td><td>1600 A</td><td>12 kA</td><td>—</td></tr> <tr><td>20 A</td><td>250 A</td><td>1800 A</td><td>15 kA</td><td>—</td></tr> <tr><td>25 A</td><td>300 A</td><td>2000 A</td><td>20 kA</td><td>—</td></tr> <tr><td>30 A</td><td>400 A</td><td>2500 A</td><td>30 kA</td><td>—</td></tr> <tr><td>40 A</td><td>500 A</td><td>3000 A</td><td>—</td><td>—</td></tr> <tr><td>50 A</td><td>600 A</td><td>4000 A</td><td>—</td><td>—</td></tr> </tbody> </table>	Setting range					Primary current				Secondary current	5 A	60 A	750 A	5000 A	5 A	6 A	75 A	800 A	6000 A	1 A	7.5 A	80 A	900 A	7500 A	—	8 A	100 A	1000 A	8000 A	—	10 A	120 A	1200 A	9000 A	—	12 A	150 A	1500 A	10 kA	—	15 A	200 A	1600 A	12 kA	—	20 A	250 A	1800 A	15 kA	—	25 A	300 A	2000 A	20 kA	—	30 A	400 A	2500 A	30 kA	—	40 A	500 A	3000 A	—	—	50 A	600 A	4000 A	—	—
Setting range																																																																								
Primary current				Secondary current																																																																				
5 A	60 A	750 A	5000 A	5 A																																																																				
6 A	75 A	800 A	6000 A	1 A																																																																				
7.5 A	80 A	900 A	7500 A	—																																																																				
8 A	100 A	1000 A	8000 A	—																																																																				
10 A	120 A	1200 A	9000 A	—																																																																				
12 A	150 A	1500 A	10 kA	—																																																																				
15 A	200 A	1600 A	12 kA	—																																																																				
20 A	250 A	1800 A	15 kA	—																																																																				
25 A	300 A	2000 A	20 kA	—																																																																				
30 A	400 A	2500 A	30 kA	—																																																																				
40 A	500 A	3000 A	—	—																																																																				
50 A	600 A	4000 A	—	—																																																																				
Phase voltage full-scale 【ULN SCALE】	Set phase voltage values for the upper limit of the analog output rating. (3P4W and 1P3W) In case of 3P3W and 1P2W, there is no setting item.	<div style="display: flex; justify-content: space-around;"> <div style="border: 1px solid black; padding: 2px;"> <p>【3P4W】</p> </div> <div style="border: 1px solid black; padding: 2px;"> <p>【1P3W】</p> </div> </div> <p>110 V rating</p> <table border="1" style="width: 100%; border-collapse: collapse;"> <thead> <tr> <th colspan="2">Setting range</th> </tr> <tr> <th>3P4W</th> <th>1P3W</th> </tr> </thead> <tbody> <tr> <td>150/√3 V</td> <td>150 V</td> </tr> <tr> <td>150 V</td> <td>300 V</td> </tr> </tbody> </table> <p>Thick-frame : Default setting</p> <table border="1" style="width: 100%; border-collapse: collapse;"> <thead> <tr> <th>Wiring type</th> <th>Setting value</th> <th>Input / Output</th> </tr> </thead> <tbody> <tr> <td>3P4W</td> <td>150/√3 V</td> <td>U1N, U2N, U3N 0...86.6 V / 4...20 mA</td> </tr> <tr> <td>1P3W</td> <td>150 V</td> <td>U1N, U3N 0...150 V / 4...20 mA</td> </tr> </tbody> </table>	Setting range		3P4W	1P3W	150/√3 V	150 V	150 V	300 V	Wiring type	Setting value	Input / Output	3P4W	150/√3 V	U1N, U2N, U3N 0...86.6 V / 4...20 mA	1P3W	150 V	U1N, U3N 0...150 V / 4...20 mA																																																					
Setting range																																																																								
3P4W	1P3W																																																																							
150/√3 V	150 V																																																																							
150 V	300 V																																																																							
Wiring type	Setting value	Input / Output																																																																						
3P4W	150/√3 V	U1N, U2N, U3N 0...86.6 V / 4...20 mA																																																																						
1P3W	150 V	U1N, U3N 0...150 V / 4...20 mA																																																																						

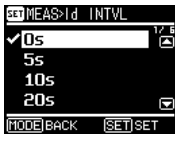
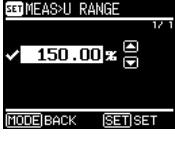
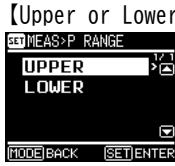
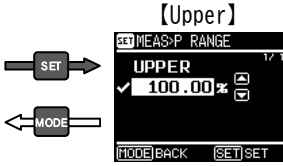

(2) Measurement setting MEAS

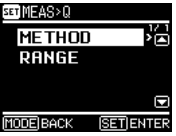
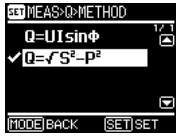
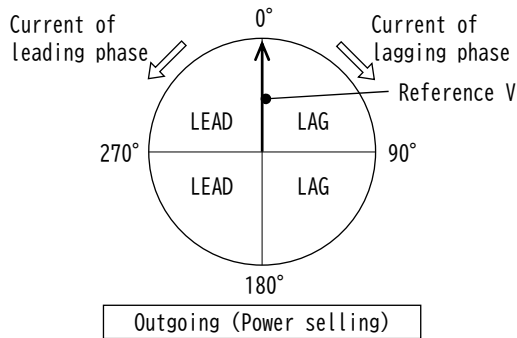
Setting item	Description	Content																																																			
Current range 【I RANGE】	Set current measurement values for the upper limit of the analog output rating range.	 <p>Thick-frame : Default setting</p> <table border="1"> <tr> <th colspan="4">Setting range</th> </tr> <tr> <td>30.00 ...</td> <td>100.00</td> <td>...120.00 %</td> <td>0.01 % step</td> </tr> </table> <p>Rated current =100.00 %</p> <p>Example of setting (CT ratio : 100 A / 5 A)</p> <table border="1"> <tr> <th>Setting value</th> <th>Input / Output</th> </tr> <tr> <td>80.00 %</td> <td>0...80 A (/4 A) / 4...20 mA</td> </tr> </table>	Setting range				30.00 ...	100.00	...120.00 %	0.01 % step	Setting value	Input / Output	80.00 %	0...80 A (/4 A) / 4...20 mA																																							
Setting range																																																					
30.00 ...	100.00	...120.00 %	0.01 % step																																																		
Setting value	Input / Output																																																				
80.00 %	0...80 A (/4 A) / 4...20 mA																																																				
Demand current interval 【Id INTVL】	Set interval of demand current measurement.	 <p>Thick-frame : Default setting</p> <table border="1"> <tr> <th colspan="6">Setting range</th> </tr> <tr> <td>0 s</td> <td>20 s</td> <td>50 s</td> <td>3 min</td> <td>6 min</td> <td>9 min</td> </tr> <tr> <td>5 s</td> <td>30 s</td> <td>1 min</td> <td>4 min</td> <td>7 min</td> <td>10 min</td> </tr> <tr> <td>10s</td> <td></td> <td></td> <td></td> <td></td> <td></td> </tr> <tr> <td>20s</td> <td></td> <td></td> <td></td> <td></td> <td></td> </tr> <tr> <td>10 s</td> <td>40 s</td> <td>2 min</td> <td>5 min</td> <td>8 min</td> <td>15 min</td> </tr> <tr> <td></td> <td></td> <td></td> <td></td> <td></td> <td>30 min</td> </tr> </table>	Setting range						0 s	20 s	50 s	3 min	6 min	9 min	5 s	30 s	1 min	4 min	7 min	10 min	10s						20s						10 s	40 s	2 min	5 min	8 min	15 min						30 min									
Setting range																																																					
0 s	20 s	50 s	3 min	6 min	9 min																																																
5 s	30 s	1 min	4 min	7 min	10 min																																																
10s																																																					
20s																																																					
10 s	40 s	2 min	5 min	8 min	15 min																																																
					30 min																																																
Voltage range 【U RANGE】	Set voltage measurement values for the upper limit of the analog output rating range.	 <p>Thick-frame : Default setting</p> <table border="1"> <tr> <th colspan="4">Setting range</th> </tr> <tr> <td>100.00 ...</td> <td>150.00</td> <td>...180.00 %</td> <td>0.01 % step</td> </tr> </table> <p>Rated voltage =110.00 %</p> <p>Example of setting (CT ratio : 100 A / 5 A)</p> <table border="1"> <tr> <th>Setting value</th> <th>Input / Output</th> </tr> <tr> <td>150.00 %</td> <td>0...9000 V (/150 V) / 4...20 mA</td> </tr> </table>	Setting range				100.00 ...	150.00	...180.00 %	0.01 % step	Setting value	Input / Output	150.00 %	0...9000 V (/150 V) / 4...20 mA																																							
Setting range																																																					
100.00 ...	150.00	...180.00 %	0.01 % step																																																		
Setting value	Input / Output																																																				
150.00 %	0...9000 V (/150 V) / 4...20 mA																																																				
Active power range 【P RANGE】	Set active power measurement values for the upper limit / lower limit of the analog output rating range.	<div style="display: flex; justify-content: space-around;"> <div data-bbox="592 779 767 943">  <p>【Upper or Lower】</p> </div> <div data-bbox="783 779 1066 943">  <p>【Upper】</p> </div> </div> <p>Thick-frame : Default setting</p> <table border="1"> <tr> <th colspan="4">Setting range</th> </tr> <tr> <td>Upper</td> <td>0.00 ...</td> <td>100.00</td> <td>...120.00 %</td> </tr> <tr> <td>Lower</td> <td>-120.00</td> <td>...</td> <td>0.00 %</td> </tr> <tr> <td></td> <td></td> <td></td> <td>0.01 % step</td> </tr> </table> <p>Rated power =100.00 %</p> <ul style="list-style-type: none"> • The output element when the "+ΣP, +P1, +P2, +P3" is selected, the range is the upper setting from zero. (Lower setting is invalid) If the upper setting is less than 20 %, the output is the lower limit of the rated output range (in case of 4...20 mA, 4 mA). • If the upper setting range from the lower setting, please select the next output element. "+ΣP, ±P1, ±P2, ±P3" • In addition, in the case where the upper setting to 0.00%, will be in the range of lower setting from zero. • Demand power and the maximum demand power, the range will be the only upper setting from the lower setting. <p>Example of setting [Rating 1000 W (110 V, 5 A)]</p> <table border="1"> <thead> <tr> <th>No.</th> <th>Output factor</th> <th>Lower settings</th> <th>Upper settings</th> <th>Input / output</th> </tr> </thead> <tbody> <tr> <td>1</td> <td>+ΣP, ±ΣP</td> <td>0.00 %</td> <td>83.33 %</td> <td>0...833.3 W / 4...20 mA</td> </tr> <tr> <td>2</td> <td>±ΣP</td> <td>-66.67 %</td> <td>66.67 %</td> <td>0...666.7 W / 1...5 V</td> </tr> <tr> <td>3</td> <td>±ΣP</td> <td>-50.00 %</td> <td>50.00 %</td> <td>-500...0...500 W / -5...0...5 V</td> </tr> <tr> <td>4</td> <td>±ΣP</td> <td>-25.00 %</td> <td>100.00 %</td> <td>-250...1000 W / 4...20 mA</td> </tr> <tr> <td>5</td> <td>±ΣP</td> <td>-50.00 %</td> <td>0.00 %</td> <td>0...-500 W / 4...20 mA</td> </tr> <tr> <td>6</td> <td>+ΣP</td> <td>-50.00 %</td> <td>0.00 %</td> <td>4 mA (For the upper limit of less than 20 % at +ΣP)</td> </tr> </tbody> </table> <p><Cautions> It cannot change into the set point from which the difference of upper set point and lower set point becomes less than 20 %.</p>	Setting range				Upper	0.00 ...	100.00	...120.00 %	Lower	-120.00	...	0.00 %				0.01 % step	No.	Output factor	Lower settings	Upper settings	Input / output	1	+ΣP, ±ΣP	0.00 %	83.33 %	0...833.3 W / 4...20 mA	2	±ΣP	-66.67 %	66.67 %	0...666.7 W / 1...5 V	3	±ΣP	-50.00 %	50.00 %	-500...0...500 W / -5...0...5 V	4	±ΣP	-25.00 %	100.00 %	-250...1000 W / 4...20 mA	5	±ΣP	-50.00 %	0.00 %	0...-500 W / 4...20 mA	6	+ΣP	-50.00 %	0.00 %	4 mA (For the upper limit of less than 20 % at +ΣP)
Setting range																																																					
Upper	0.00 ...	100.00	...120.00 %																																																		
Lower	-120.00	...	0.00 %																																																		
			0.01 % step																																																		
No.	Output factor	Lower settings	Upper settings	Input / output																																																	
1	+ΣP, ±ΣP	0.00 %	83.33 %	0...833.3 W / 4...20 mA																																																	
2	±ΣP	-66.67 %	66.67 %	0...666.7 W / 1...5 V																																																	
3	±ΣP	-50.00 %	50.00 %	-500...0...500 W / -5...0...5 V																																																	
4	±ΣP	-25.00 %	100.00 %	-250...1000 W / 4...20 mA																																																	
5	±ΣP	-50.00 %	0.00 %	0...-500 W / 4...20 mA																																																	
6	+ΣP	-50.00 %	0.00 %	4 mA (For the upper limit of less than 20 % at +ΣP)																																																	
Demand active power interval 【Pd INTVL】	Set interval of demand active power measurement.	Please set up similarly with reference to a setup (above) of the demand current interval.																																																			

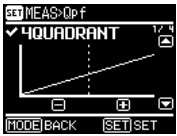
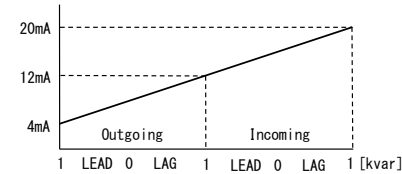
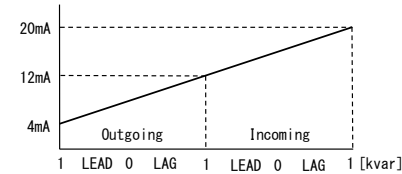
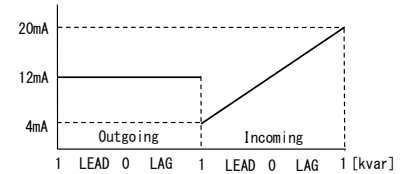
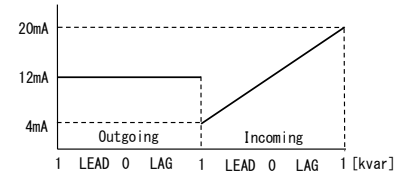
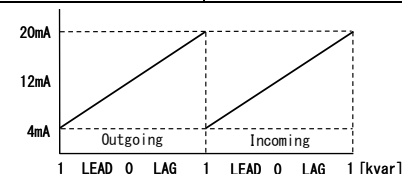
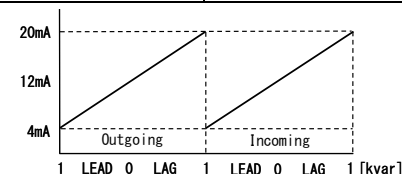
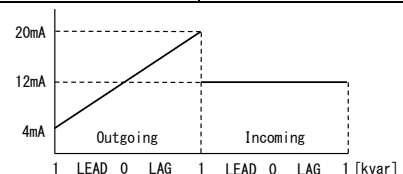
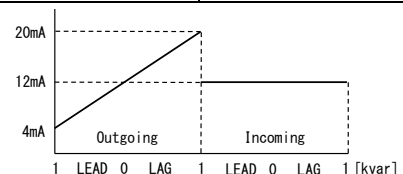
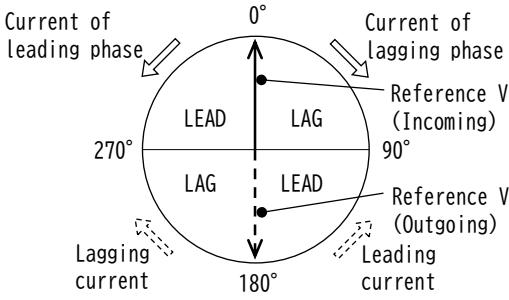
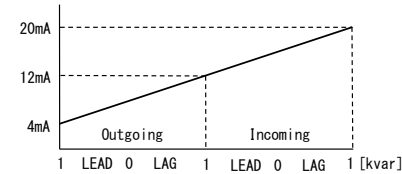
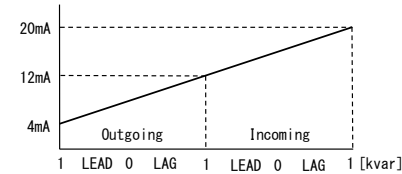
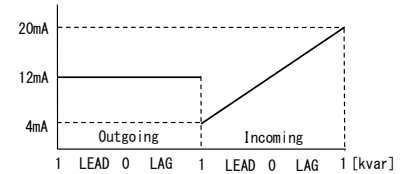
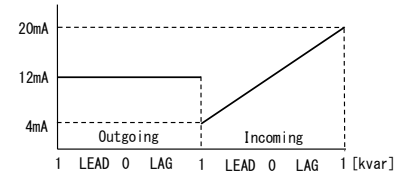
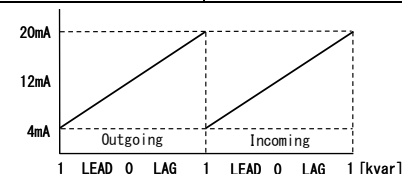
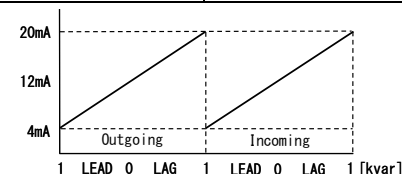
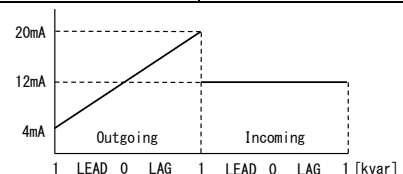
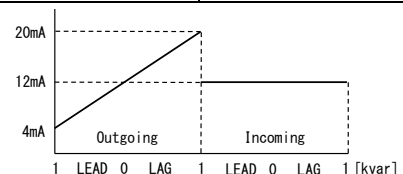
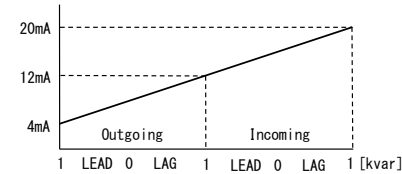
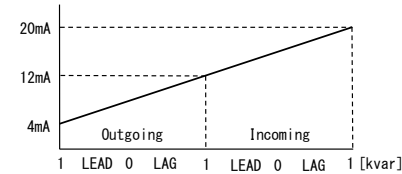
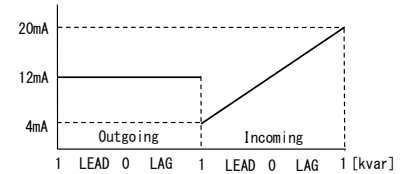
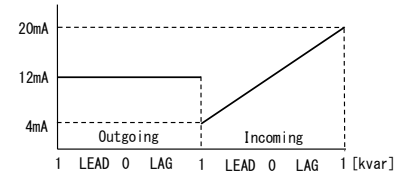
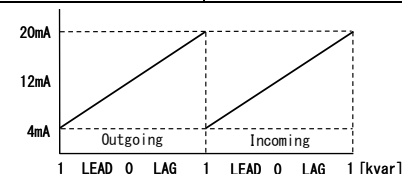
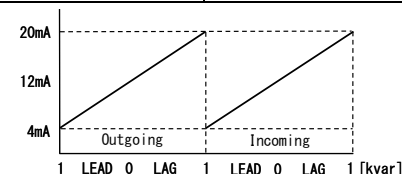
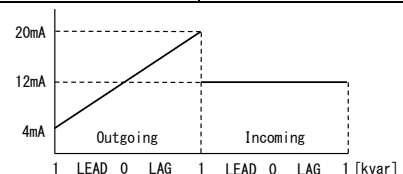
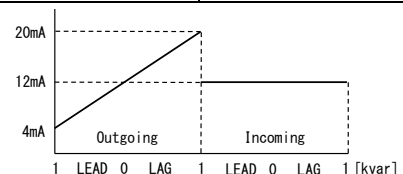
Setting item	Description	Content																																						
<p>Reactive power [Q]</p>	<p>Set operation method of reactive power. And, set reactive power measurement values for the upper limit / lower limit of the analog output rating range.</p>	<div style="display: flex; justify-content: space-between;"> <div style="width: 45%;"> <p>【Operation method / Range】</p>  <p>【Arithmetic】</p>  </div> <div style="width: 45%;"> <p>Thick-frame : Default setting</p> <table border="1" style="width: 100%;"> <tr> <th colspan="2">Setting range</th> </tr> <tr> <td>Q=UIsinφ</td> <td></td> </tr> <tr> <td>Q=√S²-P²</td> <td></td> </tr> </table> </div> </div> <p>Thick-frame : Default setting</p> <table border="1" style="width: 100%;"> <tr> <th colspan="4">Setting range (Positive : LAG, Negative : LEAD)</th> </tr> <tr> <td>Upper</td> <td>0.00 ...</td> <td>100.00 ...</td> <td>120.00 % 0.01 % step</td> </tr> <tr> <td>Lower</td> <td>-120.00 ...</td> <td>-100.00 ...</td> <td>0.00 % 0.01 % step</td> </tr> </table> <p>Rated reactive power = 100.00 %</p> <ul style="list-style-type: none"> • In the case where the upper setting to 0.00 %, will be in the range of lower setting (LEAD) from zero. • If the analog output element is a reactive power (power flow), it will be the lower setting = negative upper setting. (Lower setting is invalid) If the upper setting is less than 20 %, the output is the lower limit of the rated output range (in case of 4...20 mA, 4 mA). In this case, the upper limit set value is set to 20 % or more. <p>Example of setting [Rating 1000 var (110 V, 5 A)]</p> <table border="1" style="width: 100%;"> <thead> <tr> <th>No.</th> <th>Lower settings</th> <th>Upper settings</th> <th>Input / Output</th> </tr> </thead> <tbody> <tr> <td>1</td> <td>-75.00 %</td> <td>75.00 %</td> <td>LEAD 750...0...LAG 750 var / -5...0...5 V</td> </tr> <tr> <td>2</td> <td>-25.00 %</td> <td>100.00 %</td> <td>LEAD 250...LAG 1000 var / 4...20 mA</td> </tr> <tr> <td>3</td> <td>0.00 %</td> <td>83.33 %</td> <td>0...LAG 833.3 var / 4...20 mA</td> </tr> <tr> <td>4</td> <td>-83.33 %</td> <td>0.00 %</td> <td>0...LEAD 833.3 var / 4...20 mA</td> </tr> </tbody> </table> <p><u><Cautions> It cannot change into the set point from which the difference of upper set point and lower set point becomes less than 20 %.</u></p> <div style="text-align: center;"> <p>【LAG/LEAD polarity】</p>  </div> <p>During outgoing (P<0), polarity as viewed from the incoming side (Reference V fixed)</p>	Setting range		Q=UIsinφ		Q=√S²-P²		Setting range (Positive : LAG, Negative : LEAD)				Upper	0.00 ...	100.00 ...	120.00 % 0.01 % step	Lower	-120.00 ...	-100.00 ...	0.00 % 0.01 % step	No.	Lower settings	Upper settings	Input / Output	1	-75.00 %	75.00 %	LEAD 750...0...LAG 750 var / -5...0...5 V	2	-25.00 %	100.00 %	LEAD 250...LAG 1000 var / 4...20 mA	3	0.00 %	83.33 %	0...LAG 833.3 var / 4...20 mA	4	-83.33 %	0.00 %	0...LEAD 833.3 var / 4...20 mA
	Setting range																																							
Q=UIsinφ																																								
Q=√S²-P²																																								
Setting range (Positive : LAG, Negative : LEAD)																																								
Upper	0.00 ...	100.00 ...	120.00 % 0.01 % step																																					
Lower	-120.00 ...	-100.00 ...	0.00 % 0.01 % step																																					
No.	Lower settings	Upper settings	Input / Output																																					
1	-75.00 %	75.00 %	LEAD 750...0...LAG 750 var / -5...0...5 V																																					
2	-25.00 %	100.00 %	LEAD 250...LAG 1000 var / 4...20 mA																																					
3	0.00 %	83.33 %	0...LAG 833.3 var / 4...20 mA																																					
4	-83.33 %	0.00 %	0...LEAD 833.3 var / 4...20 mA																																					

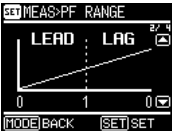
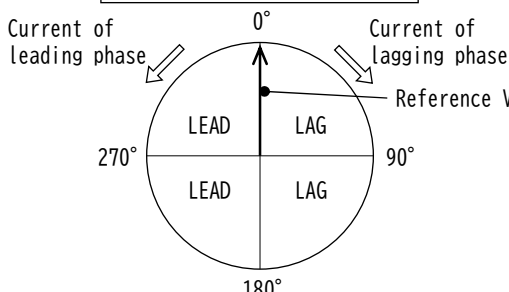
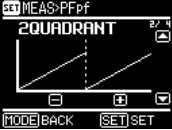
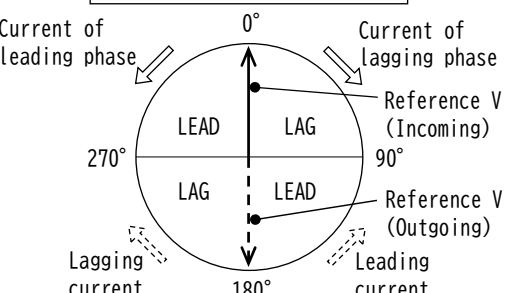
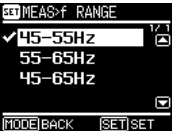
Setting item	Description	Content																				
<p>Reactive power (power flow) 【Qpf】</p>	<p>Set output method of reactive power (power flow).</p> 	<p>Operates with the reactive power Q range upper limit setting. (Lower limit value = negative upper setting) Set the upper limit value to 20% or more. If set to less than 20%, the output will be the lower limit of the rated output range.</p> <p style="text-align: right;">Thick-frame : Default setting</p> <table border="1" style="width: 100%; text-align: center;"> <thead> <tr> <th colspan="4">Setting range</th> </tr> <tr> <th>4 quadrant</th> <th>4QUADRANT</th> <th>2 quadrant (Incoming)</th> <th>2QUADRANT(+)</th> </tr> </thead> <tbody> <tr> <td></td> <td></td> <td></td> <td></td> </tr> <tr> <th>2 quadrant</th> <th>2QUADRANT</th> <th>2 quadrant (Outgoing)</th> <th>2QUADRANT(-)</th> </tr> <tr> <td></td> <td></td> <td></td> <td></td> </tr> </tbody> </table> <ul style="list-style-type: none"> • In the pattern of the two-quadrant (incoming only), is the output of the equivalent Ovar at the time of outgoing. • In the pattern of the two-quadrant (outgoing only), is the output of the equivalent Ovar at the time of incoming. <p style="text-align: center;">【LAG/LEAD polarity】</p> <div style="text-align: center;"> <p>Incoming (Power purchase)</p>  <p>Outgoing (Power selling)</p> </div> <p>During outgoing (P<0), polarity as viewed from the outgoing side (Reference V, 180° inversion)</p>	Setting range				4 quadrant	4QUADRANT	2 quadrant (Incoming)	2QUADRANT(+)					2 quadrant	2QUADRANT	2 quadrant (Outgoing)	2QUADRANT(-)				
Setting range																						
4 quadrant	4QUADRANT	2 quadrant (Incoming)	2QUADRANT(+)																			
																						
2 quadrant	2QUADRANT	2 quadrant (Outgoing)	2QUADRANT(-)																			
																						
<p>Apparent power range 【S RANGE】</p>	<p>Set apparent power measurement values for the upper limit / lower limit of the analog output rating range.</p>	<p>Please set up similarly with reference to a setup (P13) of current range.</p> <p style="text-align: right;">Thick-frame : Default setting</p> <table border="1" style="width: 100%; text-align: center;"> <thead> <tr> <th colspan="3">Setting range</th> </tr> </thead> <tbody> <tr> <td>30.00 ...</td> <td style="border: 2px solid black;">100.00</td> <td>... 120.00 %</td> </tr> <tr> <td colspan="2"></td> <td>0.01 % step</td> </tr> </tbody> </table> <p style="text-align: right;">Rated apparent power = 100.00 %</p>	Setting range			30.00 ...	100.00	... 120.00 %			0.01 % step											
Setting range																						
30.00 ...	100.00	... 120.00 %																				
		0.01 % step																				

Setting item	Description	Content										
Power factor range 【PF RANGE】	Set power factor measurement value to the rated output range of the analog output.	<div style="display: flex; justify-content: space-between;"> <div style="width: 20%;">  </div> <div style="width: 60%;"> <p style="text-align: right;">Thick-frame : Default setting</p> <table border="1" style="width: 100%;"> <thead> <tr> <th>Setting range</th> <th>Output (Example)</th> </tr> </thead> <tbody> <tr> <td>LEAD 0.5...1...LAG 0.5</td> <td>4...12...20 mA</td> </tr> <tr> <td>LEAD 0 ...1...LAG 0.5</td> <td>1... 3...5 V</td> </tr> <tr> <td>LAG 0.5...1...LEAD 0.5</td> <td>-1... 0...1 mA</td> </tr> <tr> <td>LAG 0 ...1...LEAD 0</td> <td>-5... 0...5 V</td> </tr> </tbody> </table> </div> </div> <div style="text-align: center; margin-top: 10px;"> <p>Incoming (Power purchase)</p>  <p>Outgoing (Power selling)</p> <p>During outgoing (P<0), polarity as viewed from the incoming side (Reference V fixed)</p> </div>	Setting range	Output (Example)	LEAD 0.5...1...LAG 0.5	4...12...20 mA	LEAD 0 ...1...LAG 0.5	1... 3...5 V	LAG 0.5...1...LEAD 0.5	-1... 0...1 mA	LAG 0 ...1...LEAD 0	-5... 0...5 V
Setting range	Output (Example)											
LEAD 0.5...1...LAG 0.5	4...12...20 mA											
LEAD 0 ...1...LAG 0.5	1... 3...5 V											
LAG 0.5...1...LEAD 0.5	-1... 0...1 mA											
LAG 0 ...1...LEAD 0	-5... 0...5 V											
Power factor (power flow) 【PFpf】	Set output means of current power-factor. Please set up similarly with reference to a setup (P12) of reactive power (power flow).	<div style="display: flex; justify-content: space-between;"> <div style="width: 20%;">  </div> <div style="width: 60%;"> <p style="text-align: right;">Thick-frame : Default setting</p> <table border="1" style="width: 100%;"> <thead> <tr> <th>Setting range</th> <th>Output (Example)</th> </tr> </thead> <tbody> <tr> <td>4 quadrant</td> <td>4QUADRANT</td> </tr> <tr> <td>2 quadrant</td> <td>2QUADRANT</td> </tr> <tr> <td>2 quadrant (Incoming)</td> <td>2QUADRANT(+)</td> </tr> <tr> <td>2 quadrant (Outgoing)</td> <td>2QUADRANT(-)</td> </tr> </tbody> </table> </div> </div> <div style="text-align: center; margin-top: 10px;"> <p>Incoming (Power purchase)</p>  <p>Outgoing (Power selling)</p> <p>During outgoing (P<0), polarity as viewed from the power outgoing side (Reference V, 180° inversion)</p> </div>	Setting range	Output (Example)	4 quadrant	4QUADRANT	2 quadrant	2QUADRANT	2 quadrant (Incoming)	2QUADRANT(+)	2 quadrant (Outgoing)	2QUADRANT(-)
Setting range	Output (Example)											
4 quadrant	4QUADRANT											
2 quadrant	2QUADRANT											
2 quadrant (Incoming)	2QUADRANT(+)											
2 quadrant (Outgoing)	2QUADRANT(-)											
Frequency range 【f RANGE】	Set frequency measurement value to the rated output range of the analog output.	<div style="display: flex; justify-content: space-between;"> <div style="width: 20%;">  </div> <div style="width: 60%;"> <p style="text-align: right;">Thick-frame : Default setting</p> <table border="1" style="width: 100%;"> <thead> <tr> <th>Setting range</th> <th>Output (Example)</th> </tr> </thead> <tbody> <tr> <td>45...55 Hz</td> <td>4...20 mA</td> </tr> <tr> <td>55...65 Hz</td> <td>1...5 V</td> </tr> <tr> <td>45...65 Hz</td> <td>-1...1 mA</td> </tr> </tbody> </table> </div> </div>	Setting range	Output (Example)	45...55 Hz	4...20 mA	55...65 Hz	1...5 V	45...65 Hz	-1...1 mA		
Setting range	Output (Example)											
45...55 Hz	4...20 mA											
55...65 Hz	1...5 V											
45...65 Hz	-1...1 mA											





Setting item	Description	Content																																																										
Wh/varh unit per count [Wh/varh]	Set unit per count of Wh/varh display (and communication data).	 <ul style="list-style-type: none"> Integrating the set value as the least significant digit, up to a maximum of 9 digits (999999999). Integrate again from "0" if it exceeds 9 digits. Full load power (kW/kvar) $= K \times VT \text{ primary voltage (V)} \times CT \text{ primary current (A)} \times 10^{-3}$ $K : 3P3W, 3P4W = \sqrt{3}, 1P2W = 1, 1P3W = 2$ 																																																										
		<p style="text-align: right;">Thick-frame : Default setting</p> <table border="1"> <thead> <tr> <th colspan="2">Full load power kW/kvar</th> <th colspan="4">Output pulse rate, kWh(kvarh)/pulse</th> </tr> </thead> <tbody> <tr> <td>Below 1</td> <td>0.01</td> <td>0.001</td> <td>0.0001</td> <td colspan="2">0.00001</td> </tr> <tr> <td>Over 1</td> <td>Below 10</td> <td>0.1</td> <td>0.01</td> <td>0.001</td> <td>0.0001</td> </tr> <tr> <td>Over 10</td> <td>Below 100</td> <td>1</td> <td>0.1</td> <td>0.01</td> <td>0.001</td> </tr> <tr> <td>Over 100</td> <td>Below 1,000</td> <td>(⁴) 10</td> <td>1</td> <td>0.1</td> <td>0.01</td> </tr> <tr> <td>Over 1,000</td> <td>Below 10,000</td> <td>(⁴) 100</td> <td>(⁴) 10</td> <td>1</td> <td>0.1</td> </tr> <tr> <td>Over 10,000</td> <td>Below 100,000</td> <td>(⁴) 1,000</td> <td>(⁴) 100</td> <td>(⁴) 10</td> <td>1</td> </tr> <tr> <td>Over 100,000</td> <td>Below 1,000,000</td> <td>—</td> <td>(⁴) 1,000</td> <td>(⁴) 100</td> <td>(⁴) 10</td> </tr> <tr> <td>Over 1,000,000</td> <td>Below 10,000,000</td> <td>—</td> <td>—</td> <td>(⁴) 1,000</td> <td>(⁴) 100</td> </tr> <tr> <td>Over 10,000,000</td> <td>Below 100,000,000</td> <td>—</td> <td>—</td> <td>—</td> <td>(⁴) 1,000</td> </tr> </tbody> </table> <p>Note(⁴) The unit of a display data is MWh/Mvarh.</p>	Full load power kW/kvar		Output pulse rate, kWh(kvarh)/pulse				Below 1	0.01	0.001	0.0001	0.00001		Over 1	Below 10	0.1	0.01	0.001	0.0001	Over 10	Below 100	1	0.1	0.01	0.001	Over 100	Below 1,000	(⁴) 10	1	0.1	0.01	Over 1,000	Below 10,000	(⁴) 100	(⁴) 10	1	0.1	Over 10,000	Below 100,000	(⁴) 1,000	(⁴) 100	(⁴) 10	1	Over 100,000	Below 1,000,000	—	(⁴) 1,000	(⁴) 100	(⁴) 10	Over 1,000,000	Below 10,000,000	—	—	(⁴) 1,000	(⁴) 100	Over 10,000,000	Below 100,000,000	—	—
Full load power kW/kvar		Output pulse rate, kWh(kvarh)/pulse																																																										
Below 1	0.01	0.001	0.0001	0.00001																																																								
Over 1	Below 10	0.1	0.01	0.001	0.0001																																																							
Over 10	Below 100	1	0.1	0.01	0.001																																																							
Over 100	Below 1,000	(⁴) 10	1	0.1	0.01																																																							
Over 1,000	Below 10,000	(⁴) 100	(⁴) 10	1	0.1																																																							
Over 10,000	Below 100,000	(⁴) 1,000	(⁴) 100	(⁴) 10	1																																																							
Over 100,000	Below 1,000,000	—	(⁴) 1,000	(⁴) 100	(⁴) 10																																																							
Over 1,000,000	Below 10,000,000	—	—	(⁴) 1,000	(⁴) 100																																																							
Over 10,000,000	Below 100,000,000	—	—	—	(⁴) 1,000																																																							
Harmonic interval [H INTVL]	Set interval of harmonic measurement.	 <p style="text-align: right;">Thick-frame : Default setting</p> <table border="1"> <thead> <tr> <th colspan="3">Setting range</th> </tr> </thead> <tbody> <tr> <td>0 min</td> <td>5 min</td> <td>30 min</td> </tr> <tr> <td>1 min</td> <td>10 min</td> <td>—</td> </tr> <tr> <td>2 min</td> <td>15 min</td> <td>—</td> </tr> </tbody> </table>	Setting range			0 min	5 min	30 min	1 min	10 min	—	2 min	15 min	—																																														
Setting range																																																												
0 min	5 min	30 min																																																										
1 min	10 min	—																																																										
2 min	15 min	—																																																										

(3) Analog output setting AO

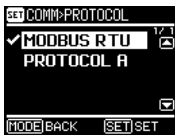

Setting item	Description	Content																																																																																																																																																																								
Output pattern [PATTERN]	The measurement element outputted to CH1...10 is set up from the pattern prepared beforehand.	 <p>Case of elements set individually CH, it will be MANUAL.</p> <p>Note(⁵) 3P4W, 1P3W : I₁, 1P2W : I Note(⁶) 3P4W, 1P3W : U_{1N}, 1P2W : U Note(⁷) 1P2W : +P, PF</p>																																																																																																																																																																								
		<p style="text-align: right;">Thick-frame : Default setting</p> <table border="1"> <thead> <tr> <th>Setting range</th> <th>Phase</th> <th>CH1</th> <th>CH2</th> <th>CH3</th> <th>CH4</th> <th>CH5</th> </tr> </thead> <tbody> <tr> <td>MANUAL</td> <td>All</td> <td colspan="5">For each element setting</td> </tr> <tr> <td rowspan="4">NORMAL</td> <td>3P3W</td> <td>I1</td> <td>I2</td> <td>I3</td> <td>U12</td> <td>U23</td> </tr> <tr> <td>3P4W</td> <td>I1</td> <td>I2</td> <td>I3</td> <td>U1N</td> <td>U2N</td> </tr> <tr> <td>1P2W</td> <td>I</td> <td>U</td> <td>+P</td> <td>Q</td> <td>PF</td> </tr> <tr> <td>1P3W</td> <td>I1</td> <td>I3</td> <td>IN</td> <td>U1N</td> <td>U3N</td> </tr> <tr> <td rowspan="4">DEMAND</td> <td>3P3W</td> <td>Id1</td> <td>Id2</td> <td>Id3</td> <td>ΣPd</td> <td>Idmax1</td> </tr> <tr> <td>3P4W</td> <td>Id1</td> <td>Id2</td> <td>Id3</td> <td>IdN</td> <td>ΣPd</td> </tr> <tr> <td>1P2W</td> <td>Id</td> <td>Pd</td> <td>Idmax</td> <td>Pdmax</td> <td>OFF</td> </tr> <tr> <td>1P3W</td> <td>Id1</td> <td>Id3</td> <td>IdN</td> <td>ΣPd</td> <td>Idmax1</td> </tr> <tr> <td>ISOLATION</td> <td>3P3W</td> <td>I1 (⁵)</td> <td>U12 (⁶)</td> <td>+ΣP (⁷)</td> <td>ΣPF (⁷)</td> <td>f</td> </tr> <tr> <td>HARMONIC</td> <td>3P3W</td> <td colspan="5">I1 (⁵)</td> </tr> <tr> <td></td> <td></td> <td>% 3rd</td> <td>% 5th</td> <td>% 7th</td> <td>% THD</td> <td>RMS 1st</td> </tr> <tr> <th>Setting range</th> <th>Phase</th> <th>CH6</th> <th>CH7</th> <th>CH8</th> <th>CH9</th> <th>CH10</th> </tr> <tr> <td>MANUAL</td> <td>All</td> <td colspan="5">For each element setting</td> </tr> <tr> <td rowspan="4">NORMAL</td> <td>3P3W</td> <td>U31</td> <td>+ΣP</td> <td>ΣQ</td> <td>ΣPF</td> <td>f</td> </tr> <tr> <td>3P4W</td> <td>U3N</td> <td>+ΣP</td> <td>ΣQ</td> <td>ΣPF</td> <td>f</td> </tr> <tr> <td>1P2W</td> <td>f</td> <td>OFF</td> <td>OFF</td> <td>OFF</td> <td>OFF</td> </tr> <tr> <td>1P3W</td> <td>U13</td> <td>+ΣP</td> <td>ΣQ</td> <td>ΣPF</td> <td>f</td> </tr> <tr> <td rowspan="4">DEMAND</td> <td>3P3W</td> <td>Idmax2</td> <td>Idmax3</td> <td>ΣPdmax</td> <td>OFF</td> <td>OFF</td> </tr> <tr> <td>3P4W</td> <td>Idmax1</td> <td>Idmax2</td> <td>Idmax3</td> <td>IdmaxN</td> <td>ΣPdmax</td> </tr> <tr> <td>1P2W</td> <td>OFF</td> <td>OFF</td> <td>OFF</td> <td>OFF</td> <td>OFF</td> </tr> <tr> <td>1P3W</td> <td>Idmax3</td> <td>IdmaxN</td> <td>ΣPdmax</td> <td>OFF</td> <td>OFF</td> </tr> <tr> <td>ISOLATION</td> <td>3P3W</td> <td>I1 (⁵)</td> <td>U12 (⁶)</td> <td>+ΣP (⁷)</td> <td>ΣPF (⁷)</td> <td>f</td> </tr> <tr> <td>HARMONIC</td> <td>3P3W</td> <td colspan="5">U12 (⁶)</td> </tr> <tr> <td></td> <td></td> <td>% 3rd</td> <td>% 5th</td> <td>% 7th</td> <td>% THD</td> <td>RMS 1st</td> </tr> </tbody> </table>	Setting range	Phase	CH1	CH2	CH3	CH4	CH5	MANUAL	All	For each element setting					NORMAL	3P3W	I1	I2	I3	U12	U23	3P4W	I1	I2	I3	U1N	U2N	1P2W	I	U	+P	Q	PF	1P3W	I1	I3	IN	U1N	U3N	DEMAND	3P3W	Id1	Id2	Id3	ΣPd	Idmax1	3P4W	Id1	Id2	Id3	IdN	ΣPd	1P2W	Id	Pd	Idmax	Pdmax	OFF	1P3W	Id1	Id3	IdN	ΣPd	Idmax1	ISOLATION	3P3W	I1 (⁵)	U12 (⁶)	+ΣP (⁷)	ΣPF (⁷)	f	HARMONIC	3P3W	I1 (⁵)							% 3rd	% 5th	% 7th	% THD	RMS 1st	Setting range	Phase	CH6	CH7	CH8	CH9	CH10	MANUAL	All	For each element setting					NORMAL	3P3W	U31	+ΣP	ΣQ	ΣPF	f	3P4W	U3N	+ΣP	ΣQ	ΣPF	f	1P2W	f	OFF	OFF	OFF	OFF	1P3W	U13	+ΣP	ΣQ	ΣPF	f	DEMAND	3P3W	Idmax2	Idmax3	ΣPdmax	OFF	OFF	3P4W	Idmax1	Idmax2	Idmax3	IdmaxN	ΣPdmax	1P2W	OFF	OFF	OFF	OFF	OFF	1P3W	Idmax3	IdmaxN	ΣPdmax	OFF	OFF	ISOLATION	3P3W	I1 (⁵)	U12 (⁶)	+ΣP (⁷)	ΣPF (⁷)	f	HARMONIC	3P3W	U12 (⁶)							% 3rd	% 5th	% 7th
Setting range	Phase	CH1	CH2	CH3	CH4	CH5																																																																																																																																																																				
MANUAL	All	For each element setting																																																																																																																																																																								
NORMAL	3P3W	I1	I2	I3	U12	U23																																																																																																																																																																				
	3P4W	I1	I2	I3	U1N	U2N																																																																																																																																																																				
	1P2W	I	U	+P	Q	PF																																																																																																																																																																				
	1P3W	I1	I3	IN	U1N	U3N																																																																																																																																																																				
DEMAND	3P3W	Id1	Id2	Id3	ΣPd	Idmax1																																																																																																																																																																				
	3P4W	Id1	Id2	Id3	IdN	ΣPd																																																																																																																																																																				
	1P2W	Id	Pd	Idmax	Pdmax	OFF																																																																																																																																																																				
	1P3W	Id1	Id3	IdN	ΣPd	Idmax1																																																																																																																																																																				
ISOLATION	3P3W	I1 (⁵)	U12 (⁶)	+ΣP (⁷)	ΣPF (⁷)	f																																																																																																																																																																				
HARMONIC	3P3W	I1 (⁵)																																																																																																																																																																								
		% 3rd	% 5th	% 7th	% THD	RMS 1st																																																																																																																																																																				
Setting range	Phase	CH6	CH7	CH8	CH9	CH10																																																																																																																																																																				
MANUAL	All	For each element setting																																																																																																																																																																								
NORMAL	3P3W	U31	+ΣP	ΣQ	ΣPF	f																																																																																																																																																																				
	3P4W	U3N	+ΣP	ΣQ	ΣPF	f																																																																																																																																																																				
	1P2W	f	OFF	OFF	OFF	OFF																																																																																																																																																																				
	1P3W	U13	+ΣP	ΣQ	ΣPF	f																																																																																																																																																																				
DEMAND	3P3W	Idmax2	Idmax3	ΣPdmax	OFF	OFF																																																																																																																																																																				
	3P4W	Idmax1	Idmax2	Idmax3	IdmaxN	ΣPdmax																																																																																																																																																																				
	1P2W	OFF	OFF	OFF	OFF	OFF																																																																																																																																																																				
	1P3W	Idmax3	IdmaxN	ΣPdmax	OFF	OFF																																																																																																																																																																				
ISOLATION	3P3W	I1 (⁵)	U12 (⁶)	+ΣP (⁷)	ΣPF (⁷)	f																																																																																																																																																																				
HARMONIC	3P3W	U12 (⁶)																																																																																																																																																																								
		% 3rd	% 5th	% 7th	% THD	RMS 1st																																																																																																																																																																				

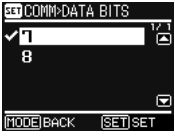
Setting item	Description	Content																																																																																																																																
Output element 【ELEMENT】	Set measurement element outputted to CH1...CH10. (CH individual)	<div style="display: flex; justify-content: space-around;"> <div style="border: 1px solid black; padding: 5px;"> <p>【CH set】</p> </div> <div style="border: 1px solid black; padding: 5px;"> <p>【Element】</p> </div> </div> <table border="1" style="width: 100%; border-collapse: collapse; text-align: center;"> <thead> <tr> <th rowspan="2">Measurement</th> <th rowspan="2">Measurands</th> <th colspan="4">Wiring type</th> </tr> <tr> <th>3P3W</th> <th>3P4W</th> <th>1P2W</th> <th>1P3W</th> </tr> </thead> <tbody> <tr> <td>Current</td> <td>I</td> <td>1, 2, 3, avg</td> <td>1, 2, 3, N, avg</td> <td>I</td> <td>1, 3, N</td> </tr> <tr> <td>Current (power flow)</td> <td>Ipf</td> <td>1, 2, 3</td> <td>1, 2, 3,</td> <td>Ipf</td> <td>1, 3</td> </tr> <tr> <td>Demand current</td> <td>Id</td> <td>1, 2, 3, avg</td> <td>1, 2, 3, N, avg</td> <td>Id</td> <td>1, 3, N</td> </tr> <tr> <td>Maximum demand current</td> <td>Idmax</td> <td>1, 2, 3, avg</td> <td>1, 2, 3, N, avg</td> <td>Idmax</td> <td>1, 3, N</td> </tr> <tr> <td>Line voltage, Phase voltage</td> <td>U</td> <td>12, 23, 31, avg</td> <td>12, 23, 31, LLavg, 1N, 2N, 3N, LNavg</td> <td>U</td> <td>13, 1N, 3N</td> </tr> <tr> <td>Active power</td> <td>P</td> <td>+Σ ±Σ</td> <td>+1, +2, +3, +Σ ±1, ±2, ±3, ±Σ</td> <td>+P ±P</td> <td>+Σ ±Σ</td> </tr> <tr> <td>Demand power</td> <td>Pd</td> <td>Σ</td> <td>1, 2, 3, Σ</td> <td>Pd</td> <td>Σ</td> </tr> <tr> <td>Maximum demand power</td> <td>Pdmax</td> <td>Σ</td> <td>1, 2, 3, Σ</td> <td>Pdmax</td> <td>Σ</td> </tr> <tr> <td>Reactive power</td> <td>Q</td> <td>Σ</td> <td>1, 2, 3, Σ</td> <td>Q</td> <td>Σ</td> </tr> <tr> <td>Reactive power (power flow)</td> <td>Qpf</td> <td>Σ</td> <td>1, 2, 3, Σ</td> <td>Qpf</td> <td>Σ</td> </tr> <tr> <td>Apparent power</td> <td>S</td> <td>Σ</td> <td>1, 2, 3, Σ</td> <td>S</td> <td>Σ</td> </tr> <tr> <td>Power factor</td> <td>PF</td> <td>Σ</td> <td>1, 2, 3, Σ</td> <td>PF</td> <td>Σ</td> </tr> <tr> <td>Power factor (power flow)</td> <td>PFpf</td> <td>Σ</td> <td>1, 2, 3, Σ</td> <td>PFpf</td> <td>Σ</td> </tr> <tr> <td>Frequency</td> <td>f</td> <td>f</td> <td>f</td> <td>f</td> <td>f</td> </tr> </tbody> </table> <table border="1" style="width: 100%; border-collapse: collapse; text-align: center;"> <thead> <tr> <th rowspan="2">Measurement</th> <th rowspan="2">Measurands</th> <th colspan="4">Wiring type</th> </tr> <tr> <th>3P3W</th> <th>3P4W</th> <th>1P2W</th> <th>1P3W</th> </tr> </thead> <tbody> <tr> <td rowspan="5">Harmonic current</td> <td>Distortion factor</td> <td rowspan="5">HI</td> <td rowspan="5">2VT2CT 1, 3</td> <td rowspan="5">1, 2, 3</td> <td rowspan="5">HI</td> <td rowspan="5">1, 3</td> </tr> <tr> <td>5th conversion content</td> </tr> <tr> <td>3rd, 5, 7, 9, 11, 13, 15th, content</td> </tr> <tr> <td>5th conversion RMS value</td> </tr> <tr> <td>Fundamental-wave RMS value</td> </tr> <tr> <td>3rd, 5, 7, 9, 11, 13, 15th, RMS value</td> </tr> <tr> <td rowspan="5">Harmonic voltage</td> <td>Distortion factor</td> <td rowspan="5">HU</td> <td rowspan="5">12, 23</td> <td rowspan="5">3VT3CT 1N, 2N, 3N</td> <td rowspan="5">HU</td> <td rowspan="5">1N, 3N</td> </tr> <tr> <td>5th conversion content</td> </tr> <tr> <td>3rd, 5, 7, 9, 11, 13, 15th, content</td> </tr> <tr> <td>5th conversion RMS value</td> </tr> <tr> <td>Fundamental-wave RMS value</td> </tr> <tr> <td>3rd, 5, 7, 9, 11, 13, 15th, RMS value</td> </tr> </tbody> </table> <p> · 1, 2, 3, N is phase. avg is the average of each phase. Σ represents the total. · If it is set as OFF, an output will serve as a lower limit value of the rated-output range. (In case of 4...20mA is 4mA.) · In the case of one side of the active power range (0...+P[W]), please select the +P. In the case of both side of the active power range (±P[W]), please select the ±P. See the power range setting for more information. </p>	Measurement	Measurands	Wiring type				3P3W	3P4W	1P2W	1P3W	Current	I	1, 2, 3, avg	1, 2, 3, N, avg	I	1, 3, N	Current (power flow)	Ipf	1, 2, 3	1, 2, 3,	Ipf	1, 3	Demand current	Id	1, 2, 3, avg	1, 2, 3, N, avg	Id	1, 3, N	Maximum demand current	Idmax	1, 2, 3, avg	1, 2, 3, N, avg	Idmax	1, 3, N	Line voltage, Phase voltage	U	12, 23, 31, avg	12, 23, 31, LLavg, 1N, 2N, 3N, LNavg	U	13, 1N, 3N	Active power	P	+Σ ±Σ	+1, +2, +3, +Σ ±1, ±2, ±3, ±Σ	+P ±P	+Σ ±Σ	Demand power	Pd	Σ	1, 2, 3, Σ	Pd	Σ	Maximum demand power	Pdmax	Σ	1, 2, 3, Σ	Pdmax	Σ	Reactive power	Q	Σ	1, 2, 3, Σ	Q	Σ	Reactive power (power flow)	Qpf	Σ	1, 2, 3, Σ	Qpf	Σ	Apparent power	S	Σ	1, 2, 3, Σ	S	Σ	Power factor	PF	Σ	1, 2, 3, Σ	PF	Σ	Power factor (power flow)	PFpf	Σ	1, 2, 3, Σ	PFpf	Σ	Frequency	f	f	f	f	f	Measurement	Measurands	Wiring type				3P3W	3P4W	1P2W	1P3W	Harmonic current	Distortion factor	HI	2VT2CT 1, 3	1, 2, 3	HI	1, 3	5th conversion content	3rd, 5, 7, 9, 11, 13, 15th, content	5th conversion RMS value	Fundamental-wave RMS value	3rd, 5, 7, 9, 11, 13, 15th, RMS value	Harmonic voltage	Distortion factor	HU	12, 23	3VT3CT 1N, 2N, 3N	HU	1N, 3N	5th conversion content	3rd, 5, 7, 9, 11, 13, 15th, content	5th conversion RMS value	Fundamental-wave RMS value	3rd, 5, 7, 9, 11, 13, 15th, RMS value
	Measurement	Measurands			Wiring type																																																																																																																													
3P3W			3P4W	1P2W	1P3W																																																																																																																													
Current	I	1, 2, 3, avg	1, 2, 3, N, avg	I	1, 3, N																																																																																																																													
Current (power flow)	Ipf	1, 2, 3	1, 2, 3,	Ipf	1, 3																																																																																																																													
Demand current	Id	1, 2, 3, avg	1, 2, 3, N, avg	Id	1, 3, N																																																																																																																													
Maximum demand current	Idmax	1, 2, 3, avg	1, 2, 3, N, avg	Idmax	1, 3, N																																																																																																																													
Line voltage, Phase voltage	U	12, 23, 31, avg	12, 23, 31, LLavg, 1N, 2N, 3N, LNavg	U	13, 1N, 3N																																																																																																																													
Active power	P	+Σ ±Σ	+1, +2, +3, +Σ ±1, ±2, ±3, ±Σ	+P ±P	+Σ ±Σ																																																																																																																													
Demand power	Pd	Σ	1, 2, 3, Σ	Pd	Σ																																																																																																																													
Maximum demand power	Pdmax	Σ	1, 2, 3, Σ	Pdmax	Σ																																																																																																																													
Reactive power	Q	Σ	1, 2, 3, Σ	Q	Σ																																																																																																																													
Reactive power (power flow)	Qpf	Σ	1, 2, 3, Σ	Qpf	Σ																																																																																																																													
Apparent power	S	Σ	1, 2, 3, Σ	S	Σ																																																																																																																													
Power factor	PF	Σ	1, 2, 3, Σ	PF	Σ																																																																																																																													
Power factor (power flow)	PFpf	Σ	1, 2, 3, Σ	PFpf	Σ																																																																																																																													
Frequency	f	f	f	f	f																																																																																																																													
Measurement	Measurands	Wiring type																																																																																																																																
		3P3W	3P4W	1P2W	1P3W																																																																																																																													
Harmonic current	Distortion factor	HI	2VT2CT 1, 3	1, 2, 3	HI	1, 3																																																																																																																												
	5th conversion content																																																																																																																																	
	3rd, 5, 7, 9, 11, 13, 15th, content																																																																																																																																	
	5th conversion RMS value																																																																																																																																	
	Fundamental-wave RMS value																																																																																																																																	
3rd, 5, 7, 9, 11, 13, 15th, RMS value																																																																																																																																		
Harmonic voltage	Distortion factor	HU	12, 23	3VT3CT 1N, 2N, 3N	HU	1N, 3N																																																																																																																												
	5th conversion content																																																																																																																																	
	3rd, 5, 7, 9, 11, 13, 15th, content																																																																																																																																	
	5th conversion RMS value																																																																																																																																	
	Fundamental-wave RMS value																																																																																																																																	
3rd, 5, 7, 9, 11, 13, 15th, RMS value																																																																																																																																		
Output specification 【SPEC】	Set rated-output range at the time of output specification (0...5 V, 1...5 V, 0...10 V). (CH individual)	<div style="display: flex; justify-content: space-around;"> <div style="border: 1px solid black; padding: 5px;"> <p>【CH set】</p> </div> <div style="border: 1px solid black; padding: 5px;"> <p>【0...5 V/1...5 V】</p> </div> </div> <table border="1" style="width: 100%; border-collapse: collapse; text-align: center;"> <thead> <tr> <th colspan="3">Setting range</th> </tr> </thead> <tbody> <tr> <td>0...5 V spec.</td> <td>1...5 V spec.</td> <td>0...10 V spec.</td> </tr> <tr> <td>0...5 V</td> <td>0...5 V</td> <td>0...10 V</td> </tr> <tr> <td>1...5 V</td> <td>1...5 V</td> <td>2...10 V</td> </tr> </tbody> </table> <p>Thick-frame : Default setting</p> <p>In the case of other output specifications, a setting item is skipped.</p>	Setting range			0...5 V spec.	1...5 V spec.	0...10 V spec.	0...5 V	0...5 V	0...10 V	1...5 V	1...5 V	2...10 V																																																																																																																				
Setting range																																																																																																																																		
0...5 V spec.	1...5 V spec.	0...10 V spec.																																																																																																																																
0...5 V	0...5 V	0...10 V																																																																																																																																
1...5 V	1...5 V	2...10 V																																																																																																																																

(5) Communication output setting COMM

Setting item	Description	Content													
Protocol 【PROTOCOL】	Set communication protocol.		Thick-frame : Default setting Setting range <table border="1"> <tr> <td>MODBUS RTU</td> <td>PROTOCOL A</td> </tr> </table>	MODBUS RTU	PROTOCOL A										
MODBUS RTU	PROTOCOL A														
Address 【ADDRESS】	Set communication address.		Thick-frame : Default setting Setting range <table border="1"> <tr> <td>MODBUS RTU</td> <td>PROTOCOL A</td> </tr> <tr> <td>1 ... 247</td> <td>1 ... 254</td> </tr> </table>	MODBUS RTU	PROTOCOL A	1 ... 247	1 ... 254								
MODBUS RTU	PROTOCOL A														
1 ... 247	1 ... 254														
Bit rate 【BIT RATE】	Set bit rate of communication.		Thick-frame : Default setting Setting range <table border="1"> <tr> <td>MODBUS RTU</td> <td>PROTOCOL A</td> </tr> <tr> <td>4800 bps</td> <td>2400 bps</td> </tr> <tr> <td>9600 bps</td> <td>4800 bps</td> </tr> <tr> <td>19200 bps</td> <td>9600 bps</td> </tr> <tr> <td>38400 bps</td> <td>19200 bps</td> </tr> </table>	MODBUS RTU	PROTOCOL A	4800 bps	2400 bps	9600 bps	4800 bps	19200 bps	9600 bps	38400 bps	19200 bps		
MODBUS RTU	PROTOCOL A														
4800 bps	2400 bps														
9600 bps	4800 bps														
19200 bps	9600 bps														
38400 bps	19200 bps														
Data bits 【DATA BITS】	Set data bits of communication.		Thick-frame : Default setting Setting range <table border="1"> <tr> <td>MODBUS RTU</td> <td>PROTOCOL A</td> </tr> <tr> <td>-</td> <td>7</td> </tr> <tr> <td>8 (Fixed value)</td> <td>8</td> </tr> </table>	MODBUS RTU	PROTOCOL A	-	7	8 (Fixed value)	8						
MODBUS RTU	PROTOCOL A														
-	7														
8 (Fixed value)	8														
Parity 【PARITY】	Set parity check method of communication.		Thick-frame : Default setting Setting range <table border="1"> <tr> <td></td> <td>MODBUS RTU</td> <td>PROTOCOL A</td> </tr> <tr> <td>Even number</td> <td>ODD</td> <td>ODD</td> </tr> <tr> <td>Odd number</td> <td>EVEN</td> <td>EVEN</td> </tr> <tr> <td>Nothing</td> <td>NONE</td> <td>NONE</td> </tr> </table>		MODBUS RTU	PROTOCOL A	Even number	ODD	ODD	Odd number	EVEN	EVEN	Nothing	NONE	NONE
	MODBUS RTU	PROTOCOL A													
Even number	ODD	ODD													
Odd number	EVEN	EVEN													
Nothing	NONE	NONE													
Stop bits 【STOP BIT】	Set stop bit of communication.		Thick-frame : Default setting Setting range <table border="1"> <tr> <td>MODBUS RTU</td> <td>PROTOCOL A</td> </tr> <tr> <td>1</td> <td>1</td> </tr> <tr> <td>2</td> <td>2</td> </tr> </table>	MODBUS RTU	PROTOCOL A	1	1	2	2						
MODBUS RTU	PROTOCOL A														
1	1														
2	2														

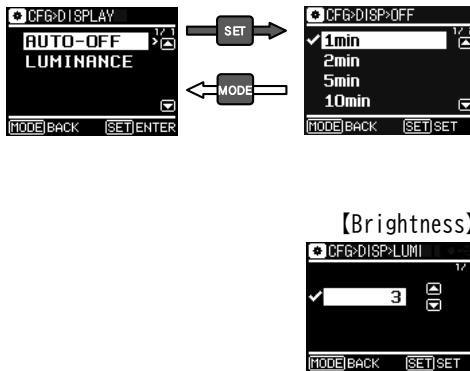
(6) Configuration CFG

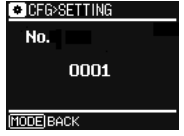
Setting item	Description	Content																
Display 【DISPLAY】	Set auto off time and brightness of the display.	<p>【Auto off time / Brightness】</p>  <p>【Auto off time】</p> <p>Backlight auto-OFF time Thick-frame : Default setting</p> <table border="1"> <thead> <tr> <th colspan="2">Setting range</th> </tr> </thead> <tbody> <tr> <td>1 minute</td> <td>10 minutes</td> </tr> <tr> <td>2 minutes</td> <td>15 minutes</td> </tr> <tr> <td>5 minutes</td> <td>30 minutes</td> </tr> </tbody> </table> <p>Backlight luminance Thick-frame : Default setting</p> <table border="1"> <thead> <tr> <th colspan="2">Setting range</th> </tr> </thead> <tbody> <tr> <td>5</td> <td rowspan="5">Bright ↑↓ Dark</td> </tr> <tr> <td>4</td> </tr> <tr> <td>3</td> </tr> <tr> <td>2</td> </tr> <tr> <td>1</td> </tr> </tbody> </table>	Setting range		1 minute	10 minutes	2 minutes	15 minutes	5 minutes	30 minutes	Setting range		5	Bright ↑↓ Dark	4	3	2	1
Setting range																		
1 minute	10 minutes																	
2 minutes	15 minutes																	
5 minutes	30 minutes																	
Setting range																		
5	Bright ↑↓ Dark																	
4																		
3																		
2																		
1																		
Reset 【RESET】	Reset maximum value (MAX), electric energy (Wh / varh) and setting value (SETTINGS).	<p>Selected in the ▲ ▼. Press SET for more than 1 second to reset (initialization).</p>  <p>Reset of all the items, select the "ALL". The items reset has been completed, mark (left side) is displayed. Subsequently, can also be reset the other items. Set value after a reset is the initial setting of a 3P3W (2VT2CT).</p>																
Software version 【SOFTWARE】	Display version of software.	<p>Version : 3-digits</p> 																
Setting management number 【SETTING No.】	Display setting management number specified in the setting software.	<p>Setting management No. : 0000...9999</p>  <p>Setting data can be used to manage and collation. Setting management numbers can not be changed in the QT2-500. When performing other setting changes at QT2-500, configuration management number will be changed to 0000.</p>																

9. Test modes

9.1 Test flow

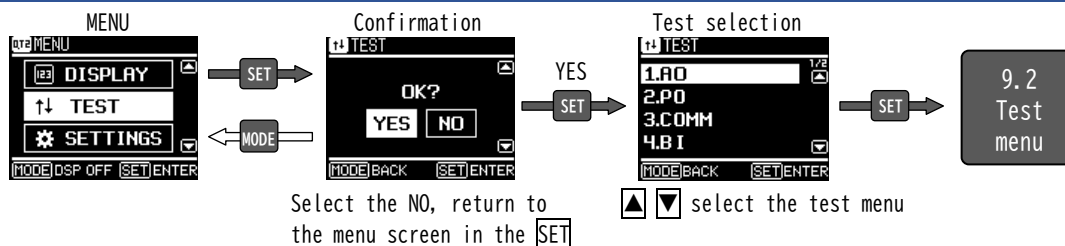

9.2 Test menu

Test item	Test content																																							
Analog output [AO]	<ul style="list-style-type: none"> Select channel (CH1 ... 10) to the test. Analog output value (0, 25, 50, 75, 100 %), selected in the ▲ ▼. Output in [SET]. <div style="display: flex; justify-content: space-around;"> <div style="text-align: center;"> <p>[CH select]</p> </div> <div style="text-align: center;"> <p>[Output select]</p> </div> </div> <p style="color: blue; text-decoration: underline;"><Note> When it becomes CH selection screen, all of the output will be the lower limit.</p> <table border="1" style="margin-left: auto; margin-right: auto;"> <caption>Setting value – Output table</caption> <thead> <tr> <th>Setting</th> <th>4...20 mA</th> <th>0...5 V</th> <th>-5...5 V</th> </tr> </thead> <tbody> <tr> <td>0 %</td> <td>4 mA</td> <td>0 V</td> <td>-5 V</td> </tr> <tr> <td>25 %</td> <td>8 mA</td> <td>1.25 V</td> <td>-2.5 V</td> </tr> <tr> <td>50 %</td> <td>12 mA</td> <td>2.5 V</td> <td>0 V</td> </tr> <tr> <td>75 %</td> <td>16 mA</td> <td>3.75 V</td> <td>2.5 V</td> </tr> <tr> <td>100 %</td> <td>20 mA</td> <td>5 V</td> <td>5 V</td> </tr> </tbody> </table>	Setting	4...20 mA	0...5 V	-5...5 V	0 %	4 mA	0 V	-5 V	25 %	8 mA	1.25 V	-2.5 V	50 %	12 mA	2.5 V	0 V	75 %	16 mA	3.75 V	2.5 V	100 %	20 mA	5 V	5 V															
Setting	4...20 mA	0...5 V	-5...5 V																																					
0 %	4 mA	0 V	-5 V																																					
25 %	8 mA	1.25 V	-2.5 V																																					
50 %	12 mA	2.5 V	0 V																																					
75 %	16 mA	3.75 V	2.5 V																																					
100 %	20 mA	5 V	5 V																																					
Pulse output [PO]	<ul style="list-style-type: none"> Select channel (CH11,12) to the test. Press the [SET], pulse is output at one-second intervals. Once again press the [SET], pulse output will stop. Pulse output number is displayed in the lower part. (0 → 1 → 2 → ... → 999 → 1000 → 1 → ...) <div style="display: flex; justify-content: space-around;"> <div style="text-align: center;"> </div> <div style="text-align: center;"> </div> </div> <p style="color: blue; text-decoration: underline;"><Note> When it becomes CH selection screen, all of the pulse output is stopped.</p>																																							
Communication output [COMM]	<ul style="list-style-type: none"> The communication output value (0, 25, 50, 75, 100%) is selected with ▲ ▼ and confirm with [SET]. Outputs the selected set value in response to a measurement value request (query, command). <div style="display: flex; justify-content: space-around;"> <div style="text-align: center;"> </div> <table border="1" style="margin-left: auto; margin-right: auto;"> <caption>Setting value – output table (110 V, 5 A, 3P3W, 45...65 Hz)</caption> <thead> <tr> <th colspan="2">Measurands</th> <th>Setting value</th> <th>Equivalent to input</th> </tr> </thead> <tbody> <tr> <td>Current</td> <td>I</td> <td>0...100 %</td> <td>0...5 A</td> </tr> <tr> <td>Current (power flow)</td> <td>Ip_f</td> <td>0...50...100 %</td> <td>-5...0...5 A</td> </tr> <tr> <td>Line voltage</td> <td>U</td> <td>0...100 %</td> <td>0...150 V</td> </tr> <tr> <td>Active power / Reactive power</td> <td>P/Q</td> <td>0...50...100 %</td> <td>-1...0...1 kW/kvar</td> </tr> <tr> <td>Apparent power</td> <td>S</td> <td>0...100 %</td> <td>0...1 kVA</td> </tr> <tr> <td>Power factor</td> <td>PF</td> <td>0...50...100 %</td> <td>LEAD 0...1...LAG 0</td> </tr> <tr> <td>Frequency</td> <td>f</td> <td>0...100 %</td> <td>45...65 Hz</td> </tr> <tr> <td rowspan="2">Distortion factor, content rate</td> <td>HI</td> <td>0...100 %</td> <td>0...100 %</td> </tr> <tr> <td>HU</td> <td>0...100 %</td> <td>0...20 %</td> </tr> </tbody> </table> </div> <p>Outputs 0, 250000, 500000, 750000, 999999 for the amount of active energy/reactive energy.</p>	Measurands		Setting value	Equivalent to input	Current	I	0...100 %	0...5 A	Current (power flow)	Ip _f	0...50...100 %	-5...0...5 A	Line voltage	U	0...100 %	0...150 V	Active power / Reactive power	P/Q	0...50...100 %	-1...0...1 kW/kvar	Apparent power	S	0...100 %	0...1 kVA	Power factor	PF	0...50...100 %	LEAD 0...1...LAG 0	Frequency	f	0...100 %	45...65 Hz	Distortion factor, content rate	HI	0...100 %	0...100 %	HU	0...100 %	0...20 %
Measurands		Setting value	Equivalent to input																																					
Current	I	0...100 %	0...5 A																																					
Current (power flow)	Ip _f	0...50...100 %	-5...0...5 A																																					
Line voltage	U	0...100 %	0...150 V																																					
Active power / Reactive power	P/Q	0...50...100 %	-1...0...1 kW/kvar																																					
Apparent power	S	0...100 %	0...1 kVA																																					
Power factor	PF	0...50...100 %	LEAD 0...1...LAG 0																																					
Frequency	f	0...100 %	45...65 Hz																																					
Distortion factor, content rate	HI	0...100 %	0...100 %																																					
	HU	0...100 %	0...20 %																																					
Binary input [BI]	<ul style="list-style-type: none"> Displays the presence or absence of the binary input. <div style="display: flex; justify-content: space-around;"> <div style="text-align: center;"> </div> <table border="1" style="margin-left: auto; margin-right: auto;"> <thead> <tr> <th>Input</th> <th>Display</th> </tr> </thead> <tbody> <tr> <td>Within input</td> <td>ON</td> </tr> <tr> <td>Without input</td> <td>OFF</td> </tr> </tbody> </table> </div>	Input	Display	Within input	ON	Without input	OFF																																	
Input	Display																																							
Within input	ON																																							
Without input	OFF																																							

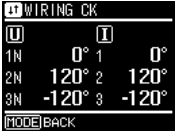
Test item	Test content											
Wiring check 【WIRING CK】	• The phase angle between the voltage and current will be displayed. (U ₁₂ or U _{1N} reference) Phase angle display in the power factor 1 (at each phase wire) If a significantly different, please check the wiring.											
												
	Measurands	3P3W 2VT, 2CT		3P3W 2VT, 3CT		3P4W 2VT, 3CT		3P4W 3VT, 3CT		1P2W		1P3W
Voltage	U ₁₂	0°	U ₁₂	0°	U _{1N}	0°	U _{1N}	0°	U	0°	U _{1N}	0°
	U ₂₃	-60°	U ₂₃	-60°	—	—	U _{2N}	120°	—	—	—	—
Current	I ₁	30°	I ₁	30°	I ₁	0°	I ₁	0°	I	0°	I ₁	0°
	—	—	I ₂	150°	I ₂	120°	I ₂	120°	—	—	—	—
	I ₃	-90°	I ₃	-90°	I ₃	-120°	I ₃	-120°	—	—	I ₃	180°

10 Specifications

10.1 Rating

Item		Specifications
Input circuit		3-phase 3-wire [3P3W] (2VT2CT, 2VT3CT) 3-phase 4-wire [3P4W] (2VT3CT, 3VT3CT) 1-phase 2-wire [1P2W] 1-phase 3-wire [1P3W] Common use (Settable)
Voltage input	3P3W 1P2W	110 V AC, 50/60 Hz 220 V AC, 50/60 Hz 440 V AC, 50/60 Hz Common use (Settable) ⁽⁸⁾
	1P3W	100-200 V AC, 50/60 Hz 200-400 V AC, 50/60 Hz Common use (Settable) ⁽⁹⁾
	3P4W	110/√3 V AC, 50/60 Hz 220/√3 V AC, 50/60 Hz 440/√3 V AC, 50/60 Hz Common use (Settable) ⁽¹⁰⁾
Current input		5 A AC, 50/60 Hz, 0.1 VA or less 1 A AC, 50/60 Hz, 0.1 VA or less Common use (Settable)
Auxiliary supply	Auxiliary supply range and power consumption	1) 80...264 V AC (Rated voltage. 100/110 V AC) 50/60 Hz, 15 VA (Rated voltage. 200/220 V AC) 50/60 Hz, 18 VA 80...264 V DC (Rated voltage. 100/110 V DC) 9 W (Rated voltage. 200/220 V DC) 10 W AC/DC common use
	Rush current (time constant)	2) 20...57 V DC (Rated voltage. 24 V DC) 11 W (Rated voltage. 48 V DC) 12 W 110 V AC : 5.5 A or less 220 V AC : 10.9 A or less 110 V DC : 3.9 A or less 220 V DC : 7.7 A or less (Approx. 5 ms) 24 V DC : 6.3 A or less 48 V DC : 12.6 A or less (Approx. 8 ms)
		Designate

Note⁽⁸⁾ Possible up to a maximum rating 480 V.

Power consumption : 0.25 VA or less (110 V), 0.5 VA or less (220 V), 1 VA or less (440 V)

Note⁽⁹⁾ Power consumption : 0.25 VA or less (100-200 V), 0.5 VA or less (200-400 V)

note⁽¹⁰⁾ Possible up to a maximum rating 480/√3 V.

Power consumption : 0.25 VA or less (110/√3 V), 0.5 VA or less (220/√3 V), 1 VA or less (440/√3 V)

10.2 Measurement item, Class

Measurement element	Measurement possible item (1, 2, 3, N : Phase, avg : Average of each phase, Σ : Total)				Class index	
	3P4W	3P3W	1P3W	1P2W	5 A	1 A
Current	I1, I2, I3, IN, Iavg	I1, I2, I3, Iavg	I1, I3, IN	I	0.2	0.5
Current (power flow)	Ipf1, Ipf2, Ipf3	Ipf1, Ipf2, Ipf3	Ipf1, Ipf3	Ipf	0.2	0.5
Demand current	Id1, Id2, Id3, IdN, Idavg	Id1, Id2, Id3, Idavg	Id1, Id3, IdN	Id	0.2	0.5
Maximum demand current	Idmax1, Idmax2, Idmax3, IdmaxN, Idmaxavg	Idmax1, Idmax2, Idmax3, Idmaxavg	Idmax1, Idmax3, IdmaxN	Idmax	0.2	0.5
Voltage	U12, U23, U31, ULLavg, U1N, U2N, U3N, ULNavg	U12, U23, U31, ULLavg	U1N, U3N, U13	U	0.2	0.2
Active power	ΣP , P1, P2, P3	ΣP	ΣP	P	0.3	0.5
Demand power	ΣPd , Pd1, Pd2, Pd3	ΣPd	ΣPd	Pd	0.3	0.5
Maximum demand power	$\Sigma Pdmax$, Pdmax1, Pdmax2, Pdmax3	$\Sigma Pdmax$	$\Sigma Pdmax$	Pdmax	0.3	0.5
Reactive power ⁽¹¹⁾	ΣQ , Q1, Q2, Q3	ΣQ	ΣQ	Q	0.3	0.5
Reactive power (power flow) ⁽¹¹⁾	ΣQpf , Qpf1, Qpf2, Qpf3	ΣQpf	ΣQpf	Qpf	0.3	0.5
Apparent power ⁽¹²⁾	ΣS , S1, S2, S3	ΣS	ΣS	S	0.3	0.5
Power factor	ΣPF , PF1, PF2, PF3	ΣPF	ΣPF	PF	1	1.5
Power factor (power flow)	$\Sigma PFpf$, PFpf1, PFpf2, PFpf3	$\Sigma PFpf$	$\Sigma PFpf$	PFpf	1	1.5
Frequency	f	f	f	f	0.2	0.2
Fundamental-wave RMS value						
Harmonic nth RMS value ⁽¹³⁾	HU1N, HU2N, HU3N, HI1, HI2, HI3 (3VT3CT : HU2N)	HU12, HU23, HI1, HI2, HI3 (2VT3CT : HI2)	HU1N, HU3N, HI1, HI3	HU, HI	Voltage : 1 Current : 1	Voltage : 1 Current : 2
Harmonic 5th conversion RMS value ⁽¹³⁾						
Distortion factor ⁽¹³⁾						
Harmonic nth content ⁽¹³⁾	HU1N, HU2N, HU3N, HI1, HI2, HI3 (3VT3CT : HU2N)	HU12, HU23, HI1, HI2, HI3 (2VT3CT : HI2)	HU1N, HU3N, HI1, HI3	HU, HI	Voltage : 2 Current : 2	Voltage : 2 Current : 2.5
Harmonic 5th conversion content ⁽¹³⁾						
Active energy	Incoming, Outgoing				1	2
Reactive energy	Incoming LAG, Incoming LEAD, Outgoing LAG, Outgoing LEAD				2	2

Note⁽¹¹⁾ The calculation method can be selected. $Q=UI\sin\phi$ or $Q=\sqrt{(S^2-P^2)}$

Note⁽¹²⁾ Calculation method. 3P4W : $\Sigma S=U1N \times I1 + U2N \times I2 + U3N \times I3$, 3P3W : $\Sigma S=\sqrt{3}/2 \times (U12 \times I1 + U23 \times I3)$, 1P3W : $\Sigma S=U1N \times I1 + U3N \times I3$

Note⁽¹³⁾ n = 3th, 5th, 7th, 9th, 11th, 13th, 15th. Distortion factor and Harmonic 5th conversion RMS value / Harmonic 5th conversion content are measured from the secondary to the 15th.

10.3 Detailed specification

Item		Specification, Performance
Conformity standards		Transducer, IEC 60688 : 2012, JIS C 1111 : 2006 Static meters for active energy, IEC 62053-21 : 2003, JIS C1271-1 : 2011 Static meters for reactive energy, IEC 62053-23 : 2003, JIS C1273-1 : 2011
CE marking		EMC Directive (2014/30/EU) EN 61000-6-2, EN 61000-4-2, -3, -4, -5, -6, -8, -11 EN 61000-6-4, EN 55011 classA, Group1 Low Voltage Directive (2014/35/EU) EN61010-1
Safety		IEC 61010-1 : 2010 Measurement Category III, Maximum use voltage : 300 V (line to neutral), Pollution degree 2
Operating method		Current, Voltage : RMS value computing type. Demand current : Arithmetic method according with bimetallic type. Demand power : Average value within the demand time limit. Power, Active energy : Time-division multiplication method. Reactive power, Reactive energy : Time division multiplication method ($Q=UI\sin\phi$) or the method for calculating from the power and apparent power ($Q=\sqrt{S^2-P^2}$). (Selected in the setting) Apparent power : Calculates for voltage and current. Power factor : Calculates for power and reactive power. Frequency : Zero cross cycle computing type. Harmonics : Fast Fourier transform
Operation period		Input 1 cycle
Influence of temperature		Usage group I 10...35 °C : Within class index. 0...45 °C : Within two times of a class index. -10...55 °C : Within three times of a class index.
Interval setting	Calculation method	Demand current is the arithmetic method according with bimetallic type. (Time to reach 95 % of a final constant value) Demand is selected from the averaging operator in a setting interval.
	Demand current	0 s / 5 s / 10 s / 20 s / 30 s / 40 s / 50 s / 1 min / 2 min / 3 min / 4 min / 5 min / 6 min / 7 min / 8 min / 9 min / 10 min / 15 min / 20 min / 25 min / 30 min
	Demand power	The response time for time limit 0 second is less than 1 second.
	Harmonics measurement	0 min / 1 min / 2 min / 5 min / 10 min / 15 min / 30 min The response time for time limit 0 minute is 2 seconds or less.
Analog output	Output	10ch Between output 1...5 and output 6...10, insulation (500V AC, 5 seconds). From elements of the measurement items of Section 10.2, it can be selected arbitrarily. (Except for active energy and reactive energy) The same elements can be selected.
	Output rating	1) 0...5 V DC (600 Ω...∞) Switchable to 1...5 V 2) 0...10 V DC (2 kΩ...∞) Switchable to 2...10 V 3) 1...5 V DC (600 Ω...∞) Switchable to 0...5 V 4) -5...5 V DC (600 Ω...∞) A) 0...1 mA DC (10 kΩ...∞) B) 4...20 mA DC (0...550 Ω) C) -1...1 mA DC (0...10 kΩ) Z) Other (Special specification)
	Response time	Response time to be restored on ±1 % of a final constant value : 1 second or less. (The response time of demand measurement and harmonics measurement is based on a time limit setting.)
	Output ripple	Output ripple is below the double (peak to peak value) of a class index to an output span.
	Current (power flow) output pattern	Set output pattern of the reactive power (power flow) and power factor (power flow). Output pattern : 4 quadrant, 2 quadrant, Incoming only measurement (2 quadrant), Outgoing only measurement (2 quadrant)
	Output adjuster	Bias and a span can be adjusted with each output. (For matching with a connection device.) Adjustable range : BIAS and SPAN, ±10 % (% for output span)
	Output limiter	The minimum value and maximum value of an output can be restricted. (Settable) Lower limit value : -1 % of output span. Upper limit value : +1 % of output span. Example) 4...20 mA : Limit the output between 3.84...20.16 mA.

Item		Specification, Performance					
Pulse output	Output	2ch					
	Output measurands	Active energy (Incoming / Outgoing), Reactive energy (Incoming LAG / Outgoing LAG / Incoming LEAD / Outgoing LEAD)					
	Output form	Optical MOS-FET relay, Normally-open contact					
	Contact capacity	125 V AC,DC, 70 mA (Resistance load, Inductive load)					
	Pulse width	250±10 ms (When the output pulse period of rated power constitutes speed more than 2 pulse / second by setting of an VT primary, a CT primary and output pulse rate, an output pulse width is 100...130 ms.)					
	Output pulse rate	Output pulse rate can be selected in the following ranges. · 3P3W, 3P4W : Full load power (kW, kvar) = $\sqrt{3} \times \text{Rated voltage (V)} \times \text{Rated current (A)} \times 10^{-3}$ · 1P3W : Full load power (kW, kvar) = $2 \times \text{Rated voltage (V)} \times \text{Rated current (A)} \times 10^{-3}$ · 1P2W : Full load power (kW, kvar) = $\text{Rated voltage (V)} \times \text{Rated current (A)} \times 10^{-3}$					
		Full load power (kW, kvar)		Output pulse rate, kWh(kvarh)/pulse			
		Below 1		0.1	0.01	0.001	0.0001
		Over 1	Below 10	1	0.1	0.01	0.001
		Over 10	Below 100	10	1	0.1	0.01
		Over 100	Below 1,000	100	10	1	0.1
Over 1,000		Below 10,000	1,000	100	10	1	
Over 10,000		Below 100,000	10,000	1,000	100	10	
Over 100,000		Below 1,000,000	100,000	10,000	1,000	100	
Over 1,000,000		Below 10,000,000	1,000,000	100,000	10,000	1,000	
Over 10,000,000	Below 100,000,000	10,000,000	1,000,000	100,000	10,000		
Communication output	Output	1ch					
	Communication system	RS-485 Half-duplex two-wire system, asynchronous communication method					
	Protocol	MODBUS RTU mode		Protocol A			
	Bit rate	4800 bps / 9600 bps / 19200 bps / 38400 bps		2400 bps / 4800 bps / 9600 bps / 19200 bps			
	Transmission code	NRZ		NRZ			
	Start bit	1 bit		1 bit			
	Data bit	8 bit		7 bit / 8 bit			
	Parity	Nothing / Even number / Odd number		Nothing / Even number / Odd number			
	Stop bit	1 bit / 2 bit		1 bit / 2 bit			
	Transmission character	Binary		ASCII code			
	Cable length	1000 m (Max.)		1000 m (Max.)			
	Address	1 to 247 (Max. connectable : 31 units)		1 to 254 (Max. connectable : 31 units)			
	Error detection	CRC-16 ($X^{16}+X^{15}+X^2+1$)		Checksum			
Termination resistor	100 Ω, 1/2 W, Install to the terminal. (Accessory)						
External reset input 【BI】	Input	1ch					
	Function	Maximum demand values can be reset by adding an external voltage signal.					
	Input rating	Input rating voltage and auxiliary supply is same. 1) 100/110 V AC, 0.4 VA (Approx. 3 mA) 200/220 V AC, 1.4 VA (Approx. 6 mA) 100/110 V DC, 0.4 W (Approx. 3 mA) 200/220 V DC, 1.4 W (Approx. 6 mA) AC,DC common use 2) 24 V DC, 0.3W (Approx. 10 mA) 48 V DC, 1.2W (Approx. 20 mA) Minimum operation pulse width : 300 ms Continuation apply time : 1 minute or less					
USB	Point	1ch					
	Function	Read-out and update the setting values are possible by connecting to PC.					
	Version	USB2.0					
	Transfer rate	12Mbps					
	Connector	Micro-USB (AB) Both of plugs (Micro-A, Micro-B) are connectable. or USB Type-C					

Item		Specification, Performance
Test function	Analog output	Without any input, and outputs an analog output (1...10 individual). 0, 25, 50, 75% output.
	Communication output	Without any input, and outputs an measured value of communication output. 0, 25, 50, 75% output.
	Pulse output	Without any input, and outputs an pulse output (1...2 individual). 1s/1pulse
	Input wiring	The wiring state of the AC input (each input of the phase) is displayed on the screen.
	Binary input	To view the status of the external reset input (BI).
Display	Display element	OLED display unit, 1 inch , Resolution : 128×96 dots Luminescent color : White Display automatic turn off (automatic turn off time after no operation can be set)
	Function	The measured value (% display) of each measurement item can be checked on the screen display.
Power interruption backup		Each setting value, maximum value and energy data are maintained in nonvolatile memory.
Insulation resistance	Between electric circuit and ground.	50 MΩ or more at 500 V DC
	Between AC input and output (analog output, pulse output, communication output) and auxiliary supply and external input.	
	Between analog output and pulse output.	
	Between pulse output and communication output.	
	Between pulse output 1 and pulse output 2.	
	Between analog output1...5 and analog output6...10 and communication output.	
Non-insulation (Minus common) : Between analog output 1...5, between analog output 6...10.		
Voltage test	Between electric circuit and ground.	2210 V AC (50/60 Hz) 5 seconds
	Between auxiliary supply and AC input, output (analog output, pulse output, communication output), external input.	
	Between analog output and pulse output.	1390 V AC (50/60 Hz) 5 seconds
	Between pulse output and communication output.	
	Between pulse output 1 and pulse output 2.	500 V AC (50/60 Hz) 5 seconds
	Between analog output 1...5, analog output 6...10 and communication output.	
Non-insulation (Minus common) : Between analog output 1...5, between analog output 6...10.		
Impulse voltage test	Between ground and auxiliary supply, AC input. (Analog output, pulse output, communication output, external input : Grounding)	6kV 1.2/50μs
	Between auxiliary supply and AC input, analog output, pulse output, communication output, external input, ground.	
	Between AC input and auxiliary supply, analog output, pulse output, communication output, external input, ground.	
	Between three-phase voltage input terminals.	
	Between auxiliary supply terminals.	2.5kV 1.2/50μs
	Between pulse output and auxiliary supply, AC input, analog output, communication output, external input, ground.	
	Between external input and auxiliary supply, AC input, analog output, pulse output, communication output, ground.	
Damped oscillatory wave immunity test IEC61000-4-12	Peak voltage : 2.5 kV, frequency : 1 MHz ±10 %, Add 3 times for 30 seconds. Error : Within ±10 %. And, malfunction and communication stop must not occur. · AC voltage input circuit (Normal / Common) · AC current input circuit (Common) · Auxiliary supply circuit (Normal / Common)	

Item		Specification, Performance
Square impulse immunity test		Add noise (1 μ s, 100 ns width) repeatedly for 5 minutes. Error : Within ± 10 %. And, malfunction and communication stop must not occur. <ul style="list-style-type: none"> · Auxiliary supply circuit (Normal / Common) 1.5 kV or more · AC voltage input circuit (Normal / Common) 1.5 kV or more · AC current input circuit (Common) 1.5 kV or more · Pulse output (Common) 1.0 kV or more · External input circuit (Common) 1.0 kV or more · Analog output (Induction) 1.0 kV or more · Communication output circuit (Induction) 1.0 kV or more
Radio wave immunity test		Radio wave band : 5W, 1m on 150 MHz, 400 MHz band. Cellular phone, wireless LAN : 2.4 GHz, 5 GHz band. Continued irradiation with radio wave on 0.5 m. Error : Within ± 10 %. And, communication should communicate normally after a noise applying stop.
Electrostatic discharge immunity test IEC 61000-4-2		Usually, it tests by the busy condition. When powered up. Air discharge : 15 kV, Contact discharge : 8 kV, Error : Within ± 10 %. And, malfunction and communication stop must not occur. Capacitor charge system
Vibration		IEC 60068-2-6 : 2007 Frequency range : 10...55 Hz, Single amplitude : 0.15 mm, Sweep cycle : 10 times
Impact		IEC 60068-2-27 : 2008 Peak acceleration : 500 m/s ² (Screw installation), 300 m/s ² (DIN rail installation)
Overload capacity	Input	2 times 10 seconds and 1.2 times continuation of rated voltage. 40 times 1 second, 20 times 4 seconds, 10 times 16 seconds, 1.2 times continuation of rated current.
	Auxiliary supply	1.5 times 10 seconds and 1.2 times continuation of rated voltage. (100/110 V AC, 200/220 V AC, 24 V DC, 48 V DC) 1.5 times 10 seconds and 1.3 times continuation of rated voltage. (110 V DC, 220 V DC)
	Output	Voltage output : Short circuit for 1 second by 10 times at 10 seconds interval, and short circuit for 5 seconds, 70 % continuation of rated-output load. Current output : Open continuation, 130 % continuation of rated-output load.
Construction	Case outline	109 \times 92 (With mounting legs, 120) \times 115 mm (W \times H \times D)
	Mass	Approx. 700g
	Material	Case : ABS (V-0) Terminal board : ABS (V-0) Terminal cover : PET-GF (HB)
	Terminal screw	Auxiliary supply, AC input, External input (BI) : M4 screw Analog output, Pulse output, Communication output : M3 screw
	Protection rating	IP30
Operating temperature and humidity limits		-10...55 $^{\circ}$ C, 5...90% RH (Non condensing)
Storage temperature limits		-25...70 $^{\circ}$ C

10.4 Measuring range

Measurands	Rated voltage Rated current		Measuring range	Low input cut	Display
Current, Demand current, Maximum demand current	—	5 A	0...5 A	Less than 0.2 % of the rated ⁽¹⁴⁾	0.0...100.0[%]
	—	1 A	0...1 A	Less than 0.5 % of the rated ⁽¹⁴⁾	
Current (Power flow)	—	5 A	Outgoing 5 A ... Incoming 5 A ⁽¹⁵⁾	Less than 0.2 % of the rated ⁽¹⁴⁾	-100.0...100.0[%]
	—	1 A	Outgoing 1 A ... Incoming 1 A ⁽¹⁵⁾	Less than 0.5 % of the rated ⁽¹⁴⁾	
Line voltage	110 V	—	0...150 V (1P3W : 0...300 V)	Less than 1 % of full scale	0.0...100.0[%]
	220 V	—	0...300 V (1P3W : 0...600 V)		
	440 V	—	0...600 V		
Phase voltage	110 V	—	3P4W : 0...150/√3 V 1P3W : 0...150 V	Less than 1 % of full scale	3P4W : 0.0...57.7[%] 1P3W : 0.0...50.0[%]
	220 V	—	3P4W : 0...300/√3 V 1P3W : 0...300 V		
	440 V	—	3P4W : 0...600/√3 V		
Active power, Demand power, Maximum demand power	110 V	5 A	-1...1 kW ⁽¹⁶⁾	Less than 0.3 % of the rated	ΣP : -100.0...100.0[%] P ₁ , P ₂ , P ₃ : -33.3...33.3[%]
	220 V		-2...2 kW ⁽¹⁶⁾		
	440 V		-4...4 kW ⁽¹⁶⁾		
	110 V	1 A	-200...200 W ⁽¹⁶⁾	Less than 0.5 % of the rated	
	220 V		-400...400 W ⁽¹⁶⁾		
	440 V		-800...800 W ⁽¹⁶⁾		
Reactive power, Reactive power (power flow 2 quadrant, 4 quadrant)	110 V	5 A	LEAD 1...LAG 1 kvar ⁽¹⁷⁾	Less than 0.3 % of the rated	ΣQ : -100.0...100.0[%] Q ₁ , Q ₂ , Q ₃ : -33.3...33.3[%]
	220 V		LEAD 2...LAG 2 kvar ⁽¹⁷⁾		
	440 V		LEAD 4...LAG 4 kvar ⁽¹⁷⁾		
	110 V	1 A	LEAD 200...LAG 200 var ⁽¹⁷⁾	Less than 0.5 % of the rated	
	220 V		LEAD 400...LAG 400 var ⁽¹⁷⁾		
	440 V		LEAD 800...LAG 800 var ⁽¹⁷⁾		
Apparent power	110 V	5 A	0...1 kVA ⁽¹⁸⁾	Less than 0.3 % of the rated	ΣS : 0.0...100.0[%] S ₁ , S ₂ , S ₃ : 0.0...33.3[%]
	220 V		0...2 kVA ⁽¹⁸⁾		
	440 V		0...4 kVA ⁽¹⁸⁾		
	110 V	1 A	0...200 VA ⁽¹⁸⁾	Less than 0.5 % of the rated	
	220 V		0...400 VA ⁽¹⁸⁾		
	440 V		0...800 VA ⁽¹⁸⁾		
Power factor, Power factor (power flow 2 quadrant, 4 quadrant)	110 V 220 V 440 V	5 A 1 A	LEAD 0...1...LAG 0 LEAD 0.5...1...LAG 0.5 LAG 0...1...LEAD 0 LAG 0.5...1...LEAD 0.5	Less than 20 % of the voltage full scale, or less than 2 % of the rated current. Incoming power factor 1.	LEAD...LAG : -0.0...100.0...0.0[%] LAG...LEAD : 0.0...100.0...-0.0[%]

Note⁽¹⁴⁾ Low input cut value of the N-phase current is twice.

Note⁽¹⁵⁾ The polarity of the current (power flow) is the same polarity as the power ΣP.
Less than 20% of the voltage full scale, then output as the incoming side.

Note⁽¹⁶⁾ 1P2W : Active power measurement range is 1/2 of the above.
3P4W : Each phase of the active power measurement range is 1/3 of the above.
0...+P or 0...-P or -P...+P, can be setting.

Note⁽¹⁷⁾ 1P2W : reactive power measurement range is 1/2 of the above.
3P4W : Each phase of the reactive power measurement range is 1/3 of the above.
0...LAG Q or 0...LEAD Q or LEAD Q...LAG Q, can be setting.

Note⁽¹⁸⁾ 1P2W : Apparent power measurement range is 1/2 of the above.
3P4W : Each phase of the apparent power measurement range is 1/3 of the above.

Measurands	Rated voltage Rated current		Measuring range	Low input cut	Display
Frequency ⁽¹⁹⁾	110 V 220 V 440 V	—	45...55 Hz 55...65 Hz 45...65 Hz	Output lower nominal value in less than 20 % of the full scale voltage (Example : 4 mA)	45.0...65.0[Hz] Low input cut : 0.0[Hz]
Fundamental-wave RMS value, Harmonic nth RMS value, Harmonic 5th conversion RMS value (n=Odd number of 3...15)	—	5 A	Measuring range is same as "current". 0...5 A 0...1 A	Less than 0.3 % of the rated ⁽²⁰⁾	0.0...100.0[%]
		1 A		Less than 0.3 % of the rated ⁽²⁰⁾	
Distortion factor, Harmonic nth content, Harmonic 5th conversion content (n=Odd number of 3...15)	110 V 220 V 440 V	—	Measuring range is same as "voltage". 3P4W, 1P3W : Phase voltage 3P3W, 1P2W : Line voltage	Less than 0.3 % of the rated ⁽²⁰⁾	
		—			
Distortion factor, Harmonic nth content, Harmonic 5th conversion content (n=Odd number of 3...15)	110 V 220 V 440 V	5 A 1 A	Current 0...100.0 %	By harmonic RMS value.	0.0...100.0[%]
		—	Voltage 0...20.0 %	By harmonic RMS value.	0.0...20.0[%]
Active energy	110 V 220 V 440 V	5 A 1 A	0...999999999 kWh(MWh) By the setting and the full load power, position and unit of the decimal point (k/M) is changed	—	0...999999999 kWh(MWh)
Reactive energy	110 V 220 V 440 V	5 A 1 A	0...999999999 kvarh(Mvarh) By the setting and the full load power, position and unit of the decimal point (k/M) is changed	—	0...999999999 kvarh(Mvarh)

Note⁽¹⁹⁾ Line voltage U_{l2} (3P3W, 1P2W) or phase voltage U_{lN} (3P4W, 1P3W) to measure the frequency.

Note⁽²⁰⁾ When the fundamental wave current is less than 3 % of the rated, degree of the harmonic measurement is 0 A. When the fundamental wave voltage of less than 3 % of the full scale, degree of the harmonic measurement is 0 V.

10.5 Input - output characteristic example

<p>■ Current, Demand current</p>	<p>■ Current (Power flow)</p>
<p>■ Line voltage</p>	<p>■ Phase voltage (3 phase 4 wire)</p>
<p>■ Active power, Demand power (Incoming, 0...+P[W])</p>	<p>■ Active power, Demand power (Outgoing and incoming, -P...+P[W])</p>
<p>■ Active power, Demand power (Outgoing, 0...-P[W])</p>	<p>■ Active power, Demand power (Outgoing and incoming, -P(a)...+P(b)[W])</p>

<p>■ Reactive power</p>	<p>■ Reactive power (Power flow) (4 quadrant)</p>
<p>■ Reactive power (Power flow) (2 quadrant)</p>	<p>■ Reactive power (Power flow) (2 quadrant, Incoming)</p>
<p>■ Reactive power (Power flow) (2 quadrant, Outgoing)</p>	<p>■ Apparent power</p>
<p>■ Power factor (LEAD 0.5...LAG 0.5)</p>	<p>■ Power factor (LEAD 0...LAG 0)</p>

<p>■ Power factor (LAG 0.5...LEAD 0.5)</p>	<p>■ Power factor (LAG 0...LEAD 0)</p>
<p>■ Power factor (Power flow) (4 quadrant, LEAD 0.5...LAG 0.5)</p>	<p>■ Power factor (Power flow) (4 quadrant, LEAD 0...LAG 0)</p>
<p>■ Power factor (Power flow) (2 quadrant, LEAD 0.5...LAG 0.5)</p>	<p>■ Power factor (Power flow) (2 quadrant, LEAD 0...LAG 0)</p>
<p>■ Power factor (Power flow) (2 quadrant, Incoming, LEAD 0.5...LAG 0.5)</p>	<p>■ Power factor (Power flow) (2 quadrant, Incoming, LEAD 0...LAG 0)</p>

<p>■ Power factor (Power flow) (2 quadrant, Outgoing, LEAD 0.5...LAG 0.5)</p>	<p>■ Power factor (Power flow) (2 quadrant, Outgoing, LEAD 0...LAG 0)</p>
<p>■ Frequency</p>	<p>■ Harmonic current, 5th conversion RMS value, fundamental-wave, nth RMS value.</p>
<p>■ Harmonic voltage, 5th conversion RMS value, fundamental-wave, nth RMS value.</p>	<p>■ Harmonic voltage, 5th conversion RMS value, fundamental-wave, nth RMS value (3-phase 4-wire)</p>
<p>■ Harmonic current, Distortion factor, 5th conversion content, nth content.</p>	<p>■ Harmonic voltage, Distortion factor, 5th conversion content, nth content.</p>

11 Multi-transducer setting software (QT2-CS-01)

11.1 Outline

Multi-transducer setting software (QT2-CS-01) is a QT2-500 dedicated setup tool. Software can be downloaded at the WEB site. (URL;http://www.daiichi-ele.co.jp/) The following data management is possible by connecting QT2-500 and PC with a USB cable.

- Edit and save setting data.
- Write setting data into QT2-500.
- Read setting data from QT2-500.
- Output the setting data in CSV file.

11.2 Hardware requirements

Item	Specification
Personal Computer	PC-AT based computer
Operating System	Windows® 8.1 (32 bits / 64 bits) Windows® 10 (32 bits / 64 bits) Windows® 11 (64 bits)
CPU	32-bit processor : 1 GHz or faster 64-bit processor : 1.6 GHz or faster
Memory	32-bit processor : 1 GB or more 64-bit processor : 2 GB or more
HDD	Free space 100 MB or more [If the Microsoft .NET Framework 4 Client Profile (32-bit) or Microsoft .NET Framework 4.5 (64-bit) is not installed. Free space of 300 MB or more]
Display	Resolution : 1024×768 or higher, High Color (65536 colors) or higher
Interface	USB2.0
Communication port	USB (A) port ×1
Other	Mouse, Keyboard

11.3 System configuration

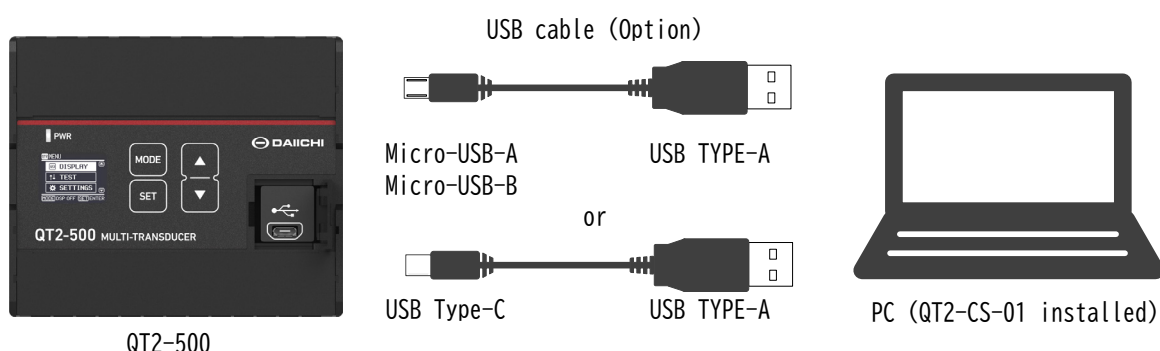

Installation, connection, such as the operation method, please refer to the included manual to QT2-CS-01.

12 Troubleshooting

Trouble	Probable cause	Handling
Power LED is not lights	In the 13th and 14th terminals, auxiliary power supply is not applied.	Please by applying an auxiliary power supply.
Display disappears	By auto off function, display is off	Please press the switch
Does not switch to the setting mode or test mode	By the lock function of the test / configuration.	Please to unlock. Pressing the MODE and SET at the same time for three seconds. Unlock or setting.
Error in analog output	Setting of VT rating and CT rating is wrong	Please check the VT/CT settings
	Output element setting is wrong	Please check the output element setting of each output CH
	Range setting of each measurement items is wrong	Please check the range settings for each measurement items
	Setting of analog output is wrong (0...5V, 1...5V, 0...10V, 2...10V)	Please check the settings of the analog output
	Wiring is wrong	Please check with the test mode wiring check function
Error in communication output	Setting of VT rating and CT rating is wrong	Please check the VT/CT settings
	Wiring is wrong	Please check with the test mode wiring check function
Error in active energy and reactive energy. (Display, Communication, Pulse output)	Setting of VT rating and CT rating is wrong	Please check the VT/CT settings
	Pulse rate setting is wrong	Please check the setting of the output pulse rate
	Wiring is wrong	Please check with the test mode wiring check function

 DAIICHI ELECTRONICS CO., LTD.

Tokyo Office : 11-13, Hitotsuya 1-chome, Adachi-ku, Tokyo, 121-8639, JAPAN.
TEL : +81-3-3885-2411 , Fax : +81-3-3858-3966

Kyoto Office : 1-19, Ichinobe-Nishikawahara, Jyoyou-shi, Kyoto, 610-0114, JAPAN.
TEL : +81-774-55-1391 , Fax : +81-774-54-1353

Revision I, DATE : May 9, 2026