

INSTRUCTION MANUAL

PLUG-IN TRANSDUCER
FINE SERIES

ALARM SETTER

FSDEL

Thank you for purchasing DAIICHI ELECTRONICS product.
Read this instruction manual carefully before installation, wiring, and using this product.

Safety precautions

■ Environment conditions

Please be sure to use this product in a place that meets the following conditions. In places that do not meet this condition, malfunctions and failures, and performance and product life may be reduced.

- Within the range of ambient temperature -10 to 55 °C, humidity 5 to 95% RH.
- Environment with low corrosive gas, dust, salt and oil smoke. (Corrosive gas: SO₂ / H₂S, etc.)
- Environment that is not affected by vibration or shock.
- Environment with less external noise.
- Altitude 1000m or less.

■ Outdoor use conditions

- These products are not a dustproof, waterproof, and splash proof construction.
Please avoid the place with much dust. Moreover, please install in the place not exposed to rain or water drop.
- Please do not install in the place where sunlight hits directly.
Discoloration and degradation of a name plate, and deformation of the case by the surface temperature rise may occur.

■ Mounting and wiring

Please refer to this instruction manual for mounting and the wiring.

 CAUTION	<ul style="list-style-type: none"> ● Please refer to connection diagram for the wiring. ● Please avoid hot line work. ● Please use an electrical wire size suitable with the rated current. ● Please check the tightening of the screw.
--	---

■ Preparation

This product must be set before use. Please read this manual and make the setting correctly.

■ Maintenance and inspection

- Inspection in energized state is dangerous.
- This product has no parts to replace during regular inspections.
- If you need to check the output while the power is on, be careful not to touch the output wiring, input terminals, or auxiliary power terminals.
- Please make sure that the power LED (POWER) is lit properly.
- Please regularly to see if wiring and mounting screws and fixing screws are not loose.
- If dust has adhered to this product, please wipe off lightly with the dry soft cloth.
Please do not use organic solvents, chemicals, cleaners, etc., such as alcohol, for cleaning.

■ Storage

Please be storage in a place that meets the following conditions.

- The ambient temperature is within -25 to 70 °C (storage temperature).
- Daily average temperature 40 °C or less.
- Location corresponding to the usage environment and use conditions.
- Location that is not affected by vibration and shock.
- Aluminum electrolytic capacitors are used for products. Please energize the power supply within one year after purchase.

■ Countermeasures against troubles.

If trouble occurs within the warranty period, DAIICHI ELECTRONICS will repair this product.

■ Disposal

Please dispose of this product as industrial waste (noncombustible).
Mercury parts and a nickel-cadmium battery are not used for this product.

■ Warranty period.

The warranty period of the product is one year after the date of delivery.

Contents

Safety precautions	1
1. Outline on the product	3
1.1 Features	3
2. Installation	
2.1 Outline dimensions	3
2.2 Cautions on mounting	4
2.3 Example of combination mounting	4
2.4 The mount to DIN rail, and the method of detachment	5
2.5 Connection diagram	6
2.6 About of auxiliary supply	7
2.7 Cautions on installation	7
3. Method of operation	
3.1 Name and function of each part	8
3.2 Display mode and operation	8
3.3 Measurement mode	9
3.4 Setting mode	10
3.5 Calibration	12
4. Model name and specification code	13
5. Specification	
5.1 Rating	13
5.2 Alarm output	14
5.3 Relay operation	15
5.4 Pre-alarm function	16
5.5 Setting value	17
5.6 Unit	18
5.7 Performance · Class	19
5.8 Electrical strength and mechanical strength	20
5.9 Noise immunity	20
5.10 EMC Directive (CE Marking)	21
5.11 Structure, Use / Storage environmental conditions, Others	22
6. Trouble shooting	22

1. Outline on the product

This product is an alarm setter of a small plug-in structure.

This product compares the DC voltage or DC current signal input with a preset operating point and outputs excess or deficiency as a contact signal.

The full scale of the input can be arbitrarily set on the actual scale according to the process amount, and each setting value (operation value, contact delay, etc.) can be freely set and changed.

1.1 Features

- Compact size.
FSDEL is the same size as our small plug-in transducer (Fine series).
- Two mounting methods.
Socket installation or mounting base (FWBA) installation.
- Bright and easy to see display.
Adopted high contrast organic light emitting display (OLED) panel for display of setting and measurement.
- Display output operation status.
The output operation status is displayed on the monitor lamp (red) on the front.
- Test function.
Alarm output operation can be confirmed without applying input.
- Wide variety of setting functions.
There are setting functions such as output mode (upper limit and lower limit, excitation and non-excitation), dead band, starting delay, contact delay and so on.

2. Installation

2.1 Outline dimensions (Unit : mm)

(1) FSDEL and socket

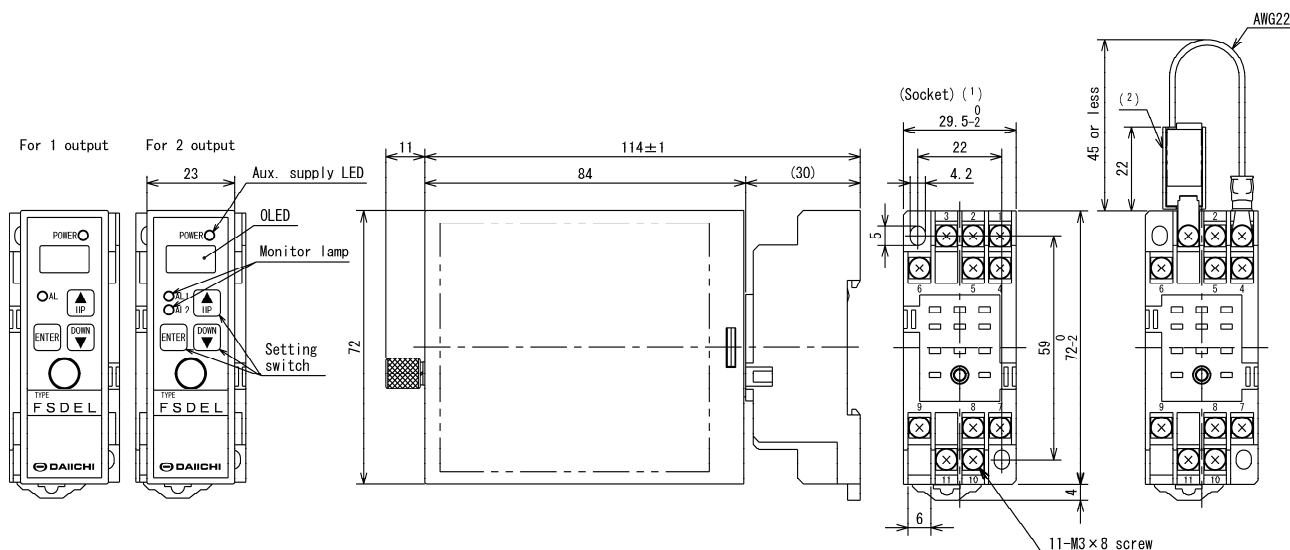

Note(1) Socket is standard attachment (FW11).

When socket is unnecessary and mounting base (model name : FWBA) is used, please specify "socket unnecessary".

The terminal screw of the socket is M3 screw (with square washer).

If you would like a M3 screw with spring washer and plain washer, please specify socket as "FW11-W".

Note(2) UR-2, precision resistance unit (option)

(2) Precision Resistance Unit, Type : UR-2 (option)

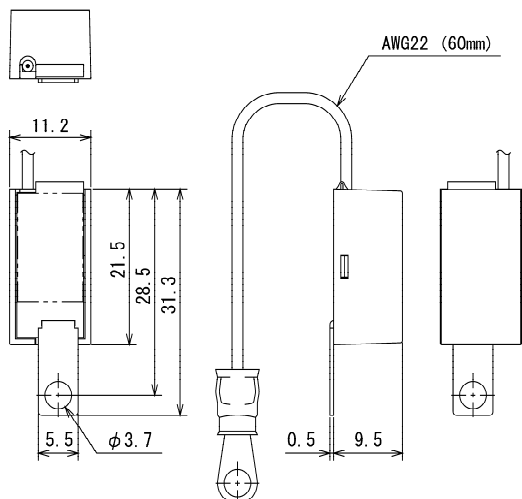

UR-2 combines an alarm setter of voltage input, and please use it. When open measures are necessary when they change an alarm setter with hot line condition in current input, they connect UR-2 to socket, and please use it by voltage signal.
(UR-2, Specify resistance value)

Resistance value of UR-2 in input signal

Current signal Resistance	DC0 to 1mA	DC0 to 10mA	DC0 to 16mA	DC0 to 20mA	DC4 to 20mA
10Ω	—	DC0 to 100mV	DC0 to 160mV	DC0 to 200mV	—
50Ω	—	—	—	DC0 to 1V	—
62.5Ω	—	—	DC0 to 1V	—	—
100Ω	DC0 to 100mV	DC0 to 1V	—	—	—
250Ω	—	—	—	DC0 to 5V	DC1 to 5V
500Ω	—	DC0 to 5V	—	DC0 to 10V	—
1kΩ	DC0 to 1V	DC0 to 10V	—	—	—

2.2 Cautions on mounting

The environmental conditions of installation space. Please select indoors without low mechanical vibration, dust, and corrosive gas. There is no limit of a mounting position.

The installation can select 35mm width DIN rail mounting and screw mounting. In screw mounting, please install with M3 screw or M4 screw. (However, the screw is not attached. The tightening torque of a screw, M3 : 0.45 to 0.60N·m, M4 : 1.00 to 1.30N·m)

Please consider radiation and wiring space and separate more than 100mm of the space above and below. (Reference of 2.3 section) Please secure the space distance of a terminal and a metal panel 10mm or more.

2.3 Example of combination mounting (Unit : mm)

Screw installation

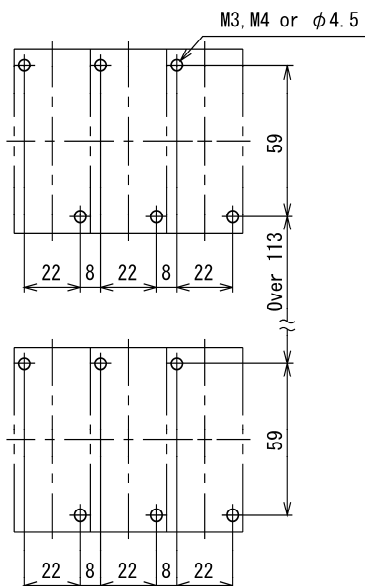

Rail installation

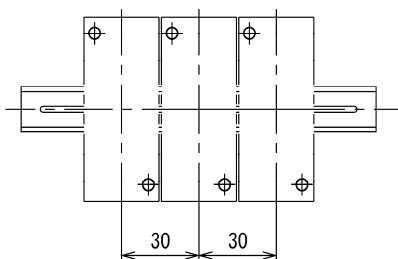

Please use rail of IEC, DIN technical standard 35mm width rail (strong type).
《Recommendation product》 Fuji electric Co.,Ltd. TH35-15AL

2.4 The mount to DIN rail, and the method of detachment.

<Cautions> If it inserts and remove the body section from a socket, please carry out after shutting down a power supply and an input signal.

(1) How to fix a socket.

Set the base socket so that its slider is at the bottom. Position the upper hook at the rear side of base socket on the DIN rail and push in the lower.

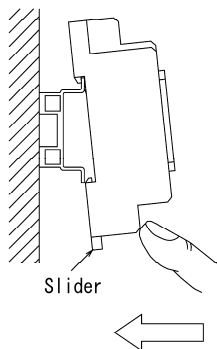

(2) How to fix a body to a socket.

Do in the direction which can read a label character correctly, and insert a body straightly. Press with the screw of a body. (Please do not tighten a screw too much.)

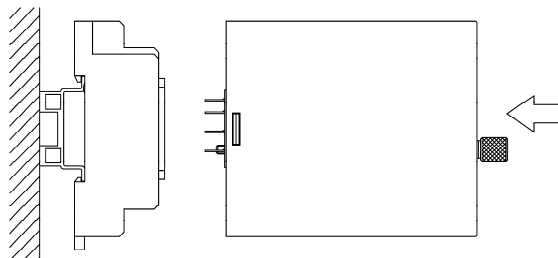

(3) How to remove a body from a socket.

Loosens the screw of a body. Please pull a body to straight near side.

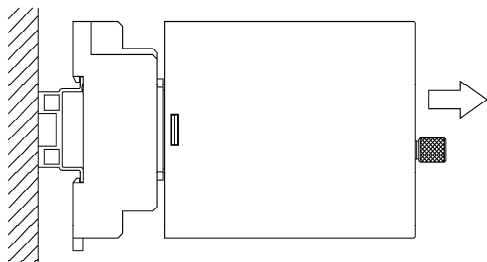

(4) How to remove a socket.

Push down the slider utilizing a minus screwdriver and pull.

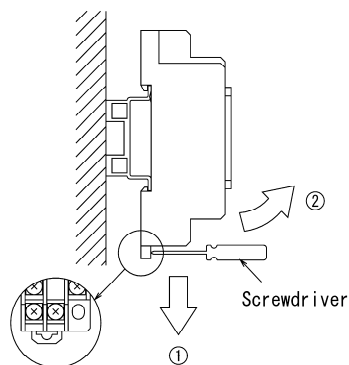

< Cautions >

If a body is taken out and inserted aslant, the terminal of a body will bend and a loose connection etc. will occur.

2.5 Connection diagram

OUTPUT 1, 2: Normally open contact (Make contact)

Socket (FW11)

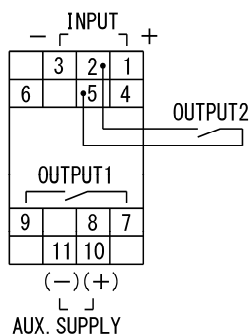

Mounting base (FWBA)

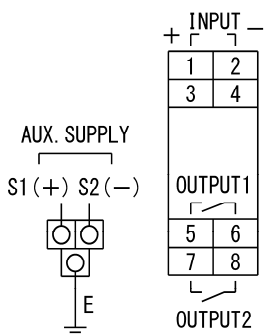

OUTPUT 1, 2: Normally close contact (Break contact)

Socket (FW11)

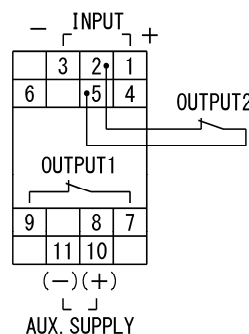

Mounting base (FWBA)

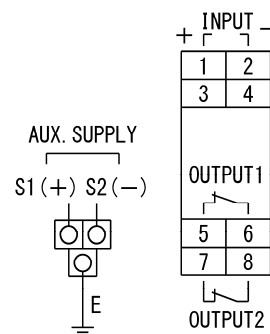

OUTPUT 1: Normally open contact (Make contact),
OUTPUT 2: Normally close contact (Break contact)

Socket (FW11)

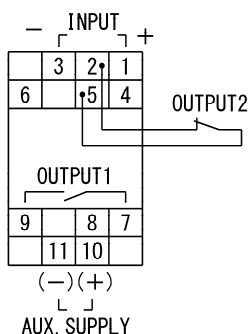

Mounting base (FWBA)

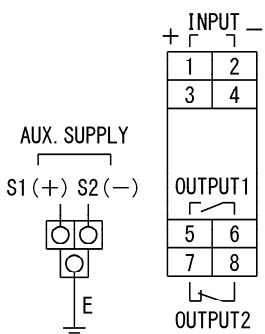

OUTPUT: Change-over contact (Transfer contact)

Socket (FW11)

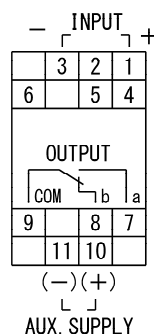

Mounting base (FWBA)

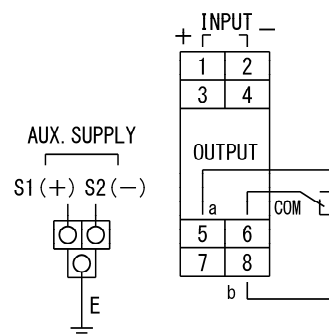

Terminals 5 and 8 are internally connected when using a socket.

<Caution>

- Please shut off the auxiliary power supply and input before starting work. Touching terminals etc. while wet hands may cause electric shock. Because burnout accident may be caused by wiring differences, please be careful of wiring. Also, it is dangerous to inspect it in places with inflammables and flammable chemicals and gases.
- When inductive loads (electromagnetic relay, etc.) are connected to output contact, it recommends attaching diode or surge killer etc. near the load.

《Spark elimination circuit example》

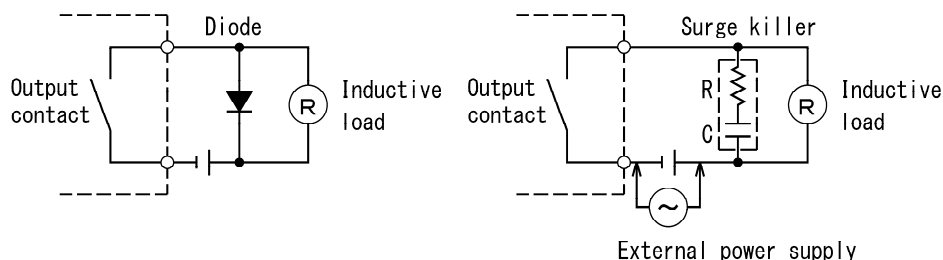

2.6 About of auxiliary supply

By applying auxiliary power to the power supply (AUX. SUPPLY) terminal of mounting base, power is supplied to each unit.

When mounting base has unit individual power switch.

Please insert this product into the mounting base and tighten the screw to fix the main body. Auxiliary power is supplied. Also, when removing, by loosening the screw, supply of auxiliary power supply is cut off. (When the auxiliary power is supplied, the power LED of this product lights up, and it turns off when it is shut off.)

Without individual unit power supply switch.

Regardless of the tightening of the fixing screw on the main unit, auxiliary power is supplied.

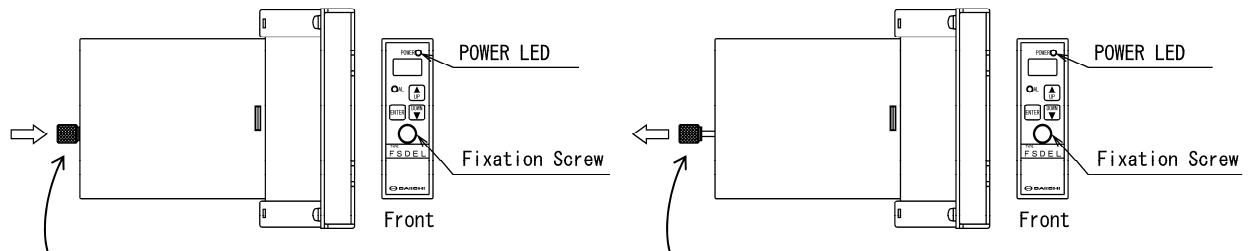

Tighten the fixing screw to supply auxiliary power supply. (Power LED will light up)

Loosening the fixing screw will shut off the auxiliary power supply. (Power LED turns off)

⚠ CAUTION

In the case of Unit with individual power switch, you should be sure to tighten the fixing screws, no auxiliary power is supplied to this product. Please be sure to tighten the fixing screw securely.

2.7 Cautions on installation

● Wiring state

Please separate wiring of input and output and perform consideration to noise. And please separate from a line with the power line used as the source of a noise and steep voltage, and current as much as possible. Please use shielding wire for the bottom of the remarkable environment of noise.

● Environmental condition

(1) Ambient temperature and humidity range

The ambient temperature and humidity during the operation of each equipment should be in the following range.

Temperature : -10 to 55 °C, humidity : 5 to 95% RH (Non condensing)

(2) Ambient atmosphere

Please be careful when using dusty environments.

Also, please consult us when using under corrosive gas [hydrogen sulfide (H₂S), chlorine (Cl), etc.] environment.

3. Method of operation

3.1 Name and function of each part

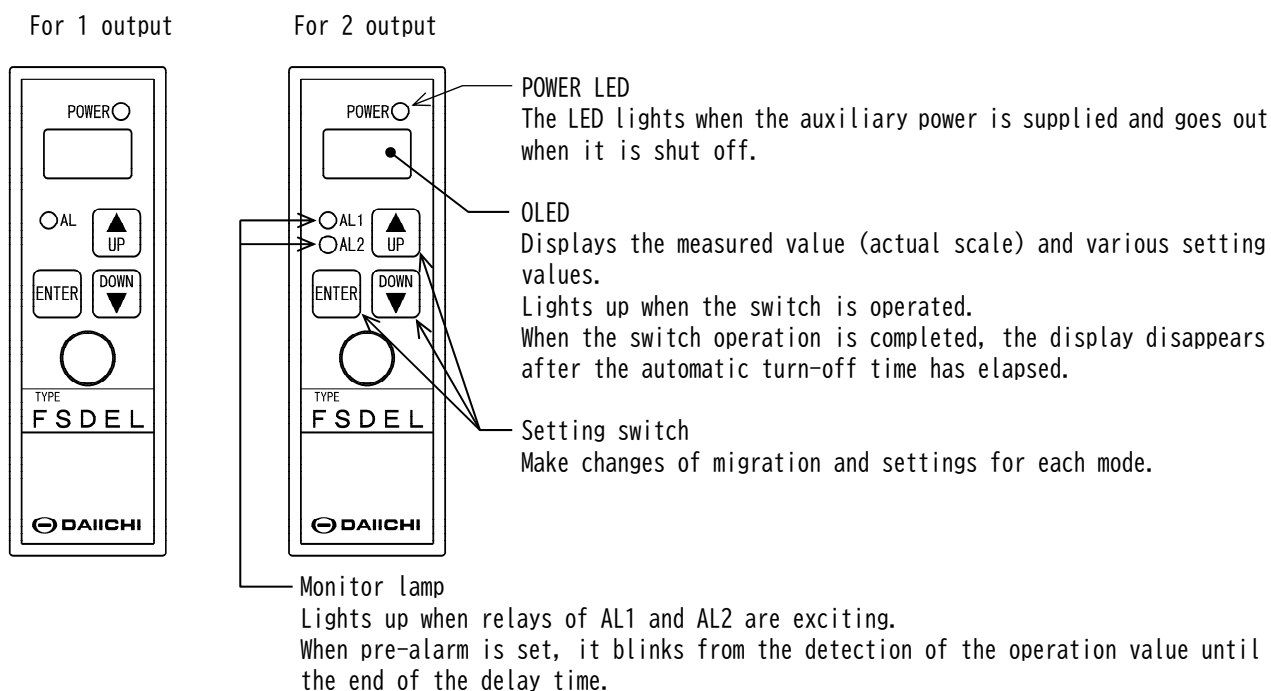

3.2 Display mode and operation

Switching of each mode

There are three display modes, and it switches to each mode by the following switch operation.

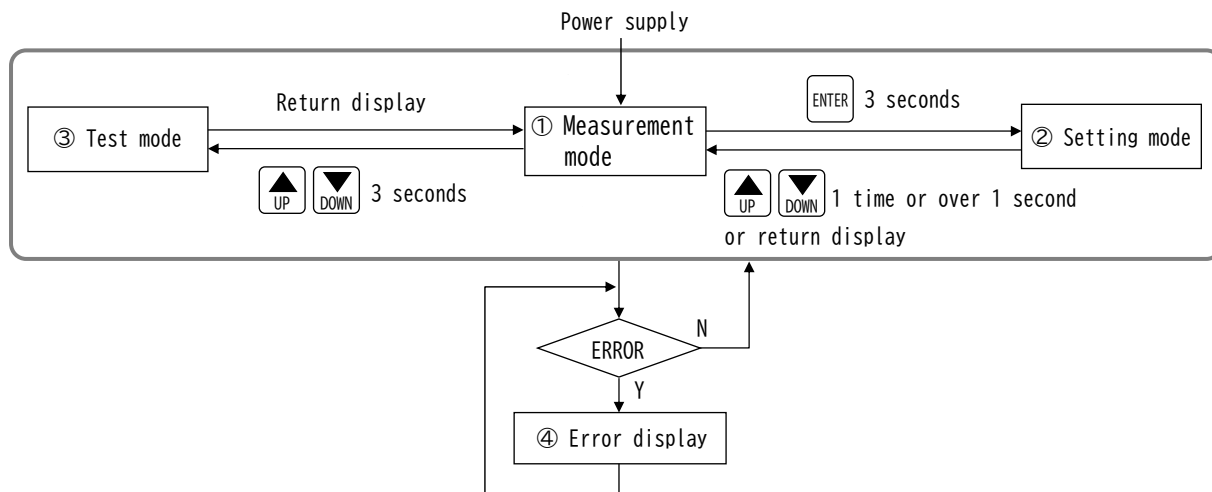

- ① Measurement mode
Input value, maximum value, minimum value, alarm output 1 display (ON / OFF display ⇔ setting value display), alarm output 2 display (ON / OFF display ⇔ setting value display)
- ② Setting mode
Select the Setup item, and change the setting value.
- ③ Test mode
Alarm output can be turned ON/OFF without adding input.
- ④ Error display
The error contents are displayed when an error occurs.

3.3 Measurement mode

After turning on the auxiliary power supply, the measurement mode is entered and each measurement can be confirmed. [Input value display, Maximum value display, Minimum value display, Alarm output 1 display (ON/OFF ⇔ Setting value), Alarm output 2 display (ON/OFF ⇔ Setting value)]

Press **UP** or **DOWN** to switch display.

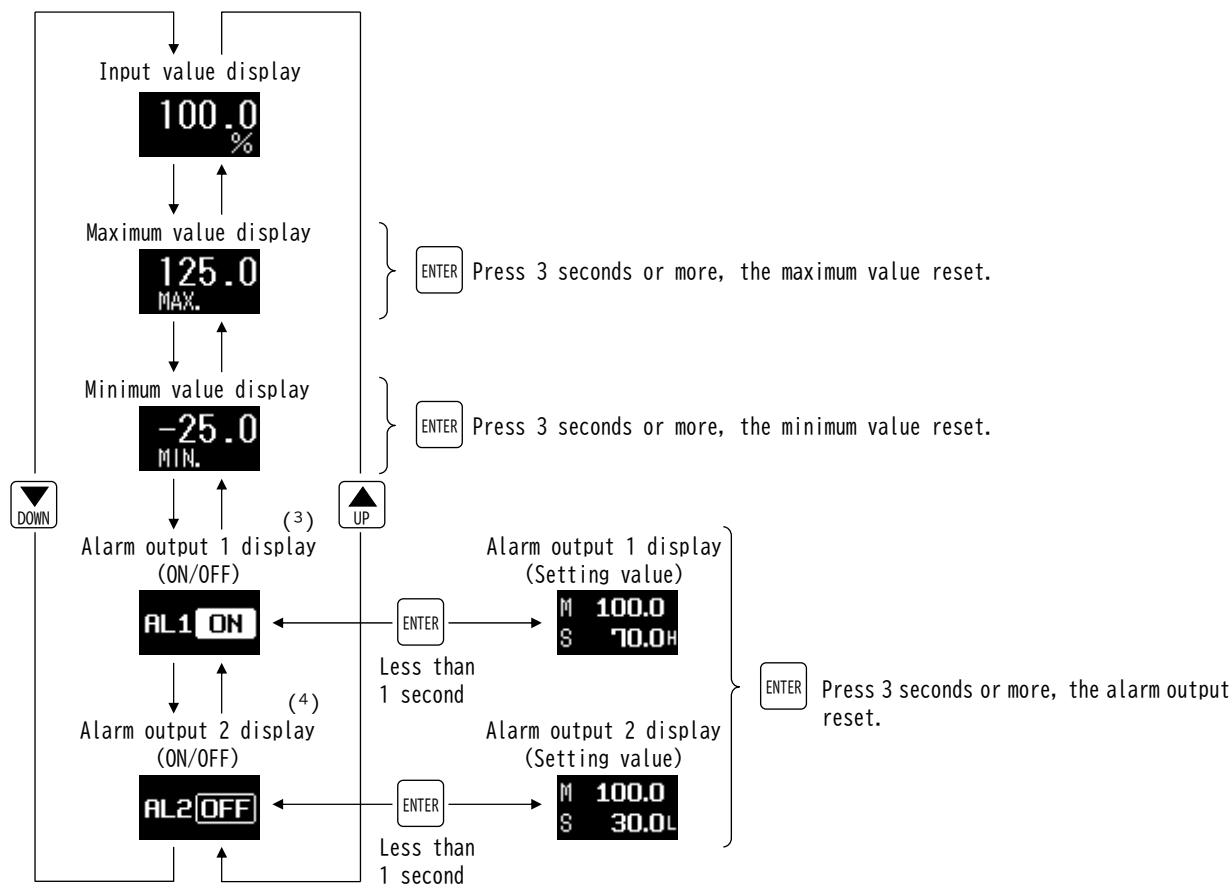

Note⁽³⁾ 1 output is AL.
 Note⁽⁴⁾ 2 output only.

About of alarm output display (Setting value display)

M 100.0 The input value is displayed in the upper row.
 S 70.0H The operation value of the alarm output is displayed in the lower row.
 H : Upper limit detection
 L : Lower limit detection

3.4 Setting mode (Each set value can be changed.)

Pressing **ENTER** for 3 seconds or longer with input value display switches to setting mode.

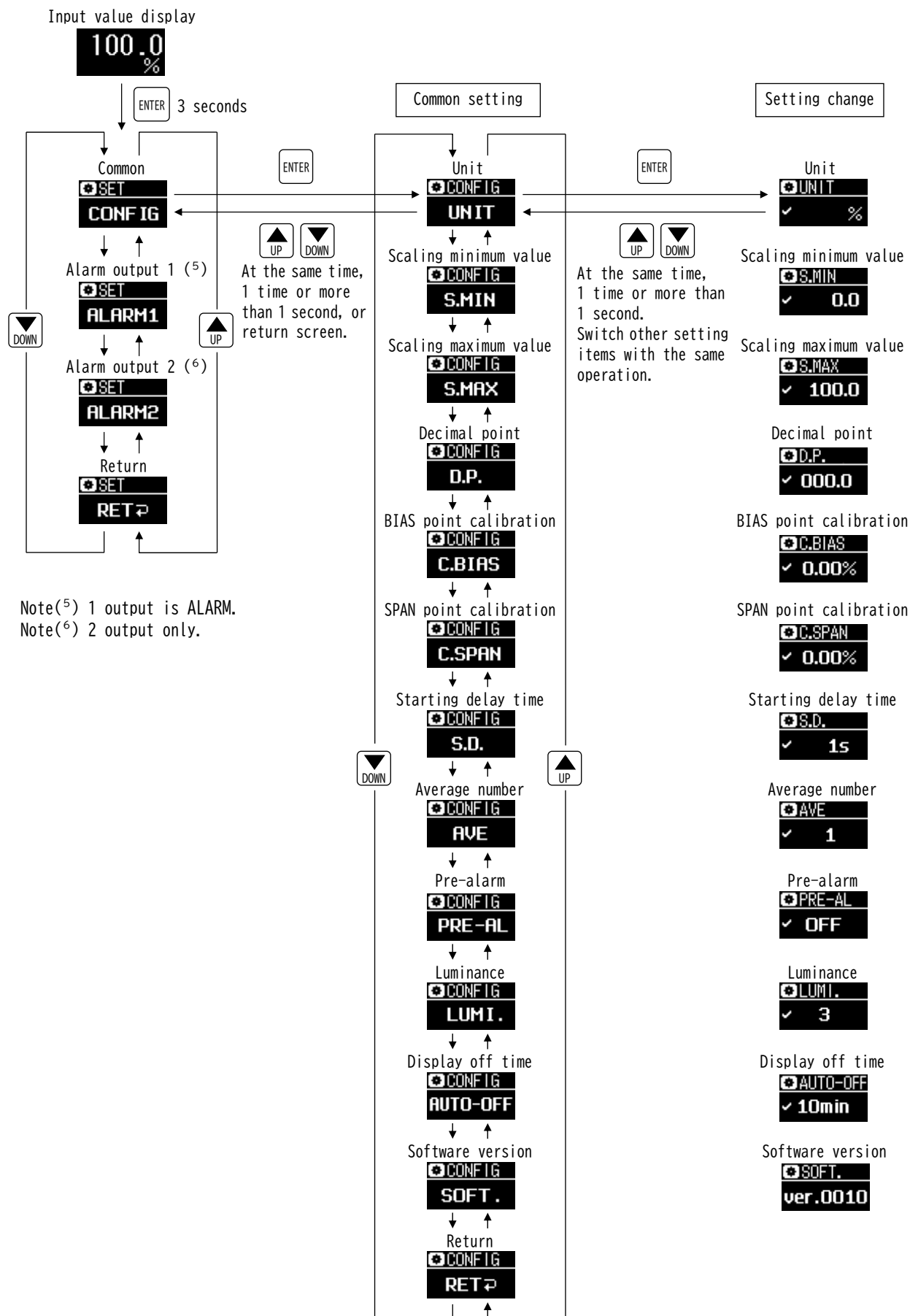

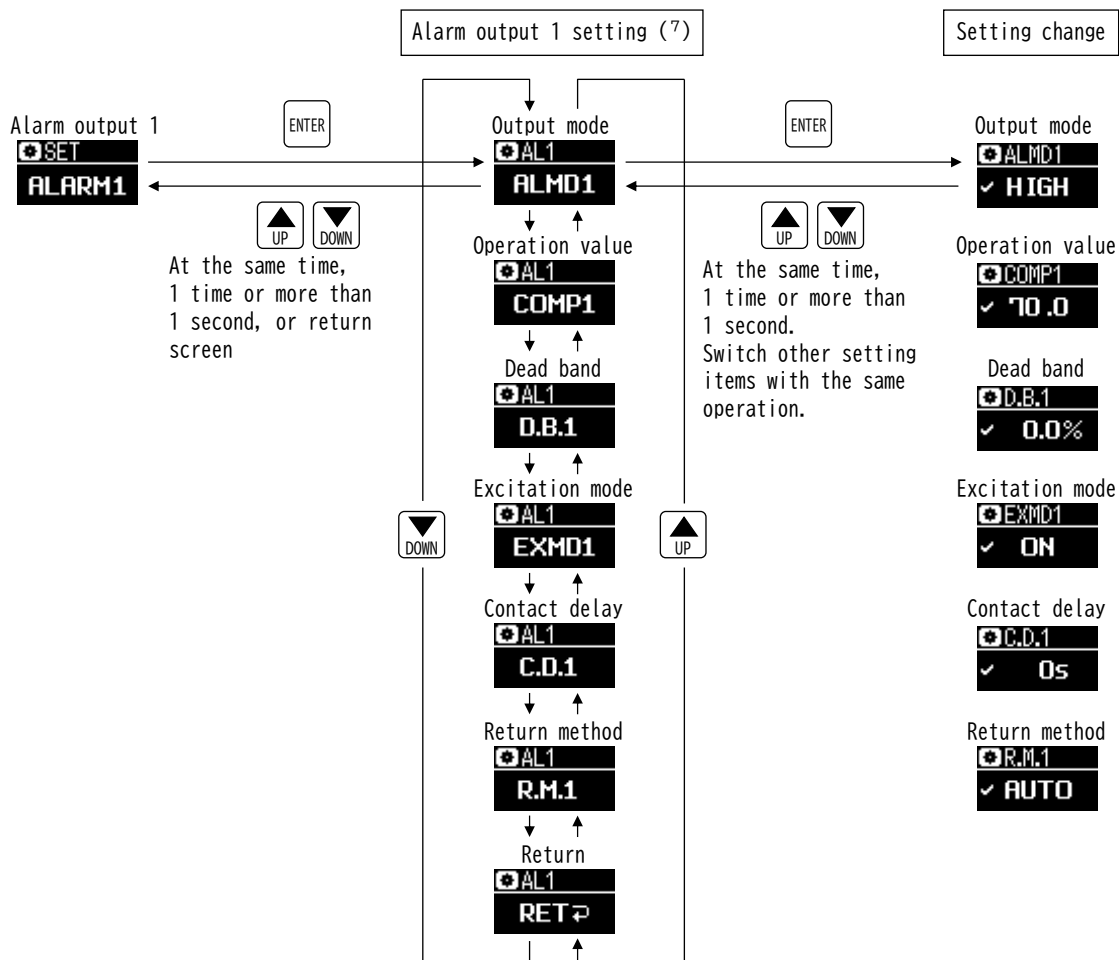

Note(7) When 1 output is selected, the display of each setting item is different.
 (Example) 2 output: ALMD 1, 1 output: ALMD etc.

* Alarm output 2 is the same setting item as alarm output 1.

● When setting units

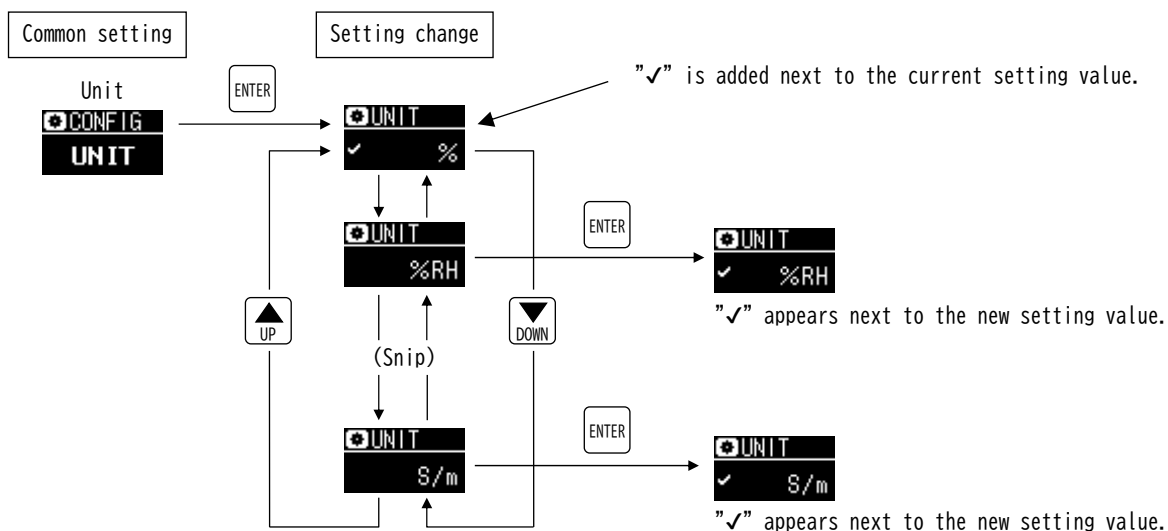

- Test mode
Pressing **UP** and **DOWN** for more than 3 seconds in the measurement mode switches to the test mode.
Normal detection operation is not performed during the test mode.

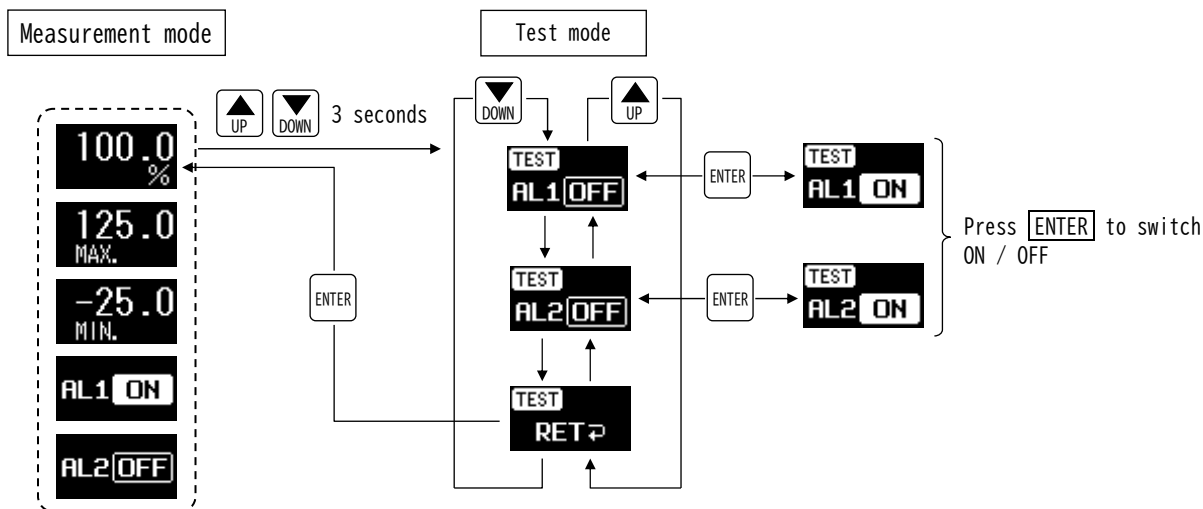

- Error display
When an error occurs, it switches to the error display.

RAM ERR
FRAM ERR
AD ERR

Error display	Error contents
RAM ERR	RAM lead / right error
FRAM ERR	Save data error of the non-volatile memory
AD ERR	A/D converter error

3.5 Calibration

Because output adjustment of this product is done, there is no necessity for calibration. However, if an operating point of alarm output shifts in the use over many years, please adjust in the next way.

- (1) After applying auxiliary power supply, pre-energize (warm up) for 15 minutes.
- (2) Set the setting value C.BIAS so that the minimum display is obtained when the input corresponding to the minimum display is applied.
Next, set the setting value C.SPAN so that the maximum display is obtained when the input corresponding to the maximum display is applied.
Confirm the above again, calibration is completed if the display matches.
For setting of the set values C.BIAS and C.SPAN, see Section 3.4 "Setting mode".
- (3) Confirm the operation value, return value, dead band.

4. Model name and specification code

TYPE	Specification code
FSDEL-	① ② ③ ④

① Input (Input resistance)		② Alarm output		
			Output 1	Output 2
0A8	DC1 to 5V (About 1MΩ)	1	Change-over contact (Transfer contact)	—
0C7	DC4 to 20mA (About 100Ω)	2	Normally open contact (Make contact)	Normally open contact (Make contact)
ZZZ	Other	3	Normally close contact (Break contact)	Normally close contact (Break contact)
		4	Normally open contact (Make contact)	Normally close contact (Break contact)

③ Auxiliary supply		④ Fuse for auxiliary supply	
F	AC80 to 264V DC80 to 264V [Rated voltage AC100/110V 50/60Hz AC200/220V 50/60Hz DC100/110V]	1	Without fuse
		2	With fuse
5	DC19 to 30V [Rated voltage DC24V]		

5. Specification

5.1 Rating

Item		Specifications		
Input	Quantity	1 circuit		
	DC voltage input	DC60mV to less than 1V DC±60mV to less than ±1V DC1V to 60V DC±1V to ±60V		
	DC current input	DC1mA to 50mA DC±1mA to ±50mA		
Alarm output	Contact composition and output points	1 point : Change-over contact (Transfer contact) 2 points : Each normally open contact (Make contact) Each normally close contact (Break contact) Individually, Normally open contact / Normally close contact	Omron Corporation, G6S-2F DC12V	
	Contact capacity	Maximum switching load	AC125V 0.5A	Resistance load
			DC110V 0.5A	Resistance load
			AC125V 0.1A	Inductive load cosφ=0.4
			DC110V 0.1A	Inductive load L/R=7ms
			DC30V 0.5A	Inductive load L/R=7ms
		Minimum switching load	DC10mV 10μA	
Mechanical life	Over 100 million times (Switching frequency 36,000 times/h)			
Electrical life	AC, Over 100,000 times (Switching frequency 1800 times/h)			
	DC, Over 100,000 times (Switching frequency 1200 times/h)			
Auxiliary supply	Auxiliary supply range,	AC80 to 264V (AC100/110V 4.0VA , AC200/220V 5.5VA) DC80 to 264V (DC100/110V 2.5W)		
	Power consumption	DC19 to 30V (DC24V 2.0W)		
	Inrush current (Time constant)	AC110V 1.6A or less (1.3ms or less), AC220V 3.2A or less (1.3ms or less) DC110V 1.1A or less (1.3ms or less) DC24V 1.9A or less (3.3ms or less)		

5.2 Alarm output

Item		Function	
Output mode	Output mode setting	Setting in five kinds of modes as follows is possible for operation of detection. ① High limit detection (H), Alarm output, relay excitation ② High limit detection (H), Alarm output, Relay non-excitation ③ Low limit detection (L), Alarm output, relay excitation ④ Low limit detection (L), Alarm output, Relay non-excitation ⑤ OFF, Always relay non-excitation.	
Relay excitation status display		At each of the contacts, the monitor lamp lights up when the relay is excited. The monitor lamp blinks during the delay time when the pre-alarm setting is ON.	
Relay and monitor lamp operation	Auxiliary supply OFF, or relay non-excitation	Relay normally close contact (Break contact) "ON", Monitor lamp "OFF".	
	Relay excitation	Relay normally open contact (Make contact) "ON", Monitor lamp "ON".	
	Output mode	▽ Operation value setting Input upper limit →	
	Excitation	H	<p>● : Monitor lamp ON ○ : Monitor lamp OFF</p>
		L	
	Non-excitation	H	
L			
OFF (Excitation · Non-excitation)	Monitor lamp	○	
Relay	Non-excitation	○	
Relay contact status	Output, Contact composition	Alarm output, 1 point : Change-over contact (Transfer contact)	
	Auxiliary supply OFF or relay non-excitation	<p>Terminal No. 7 8 9</p>	
	Relay excitation	<p>Terminal No. 7 8 9</p>	
	Output, Contact composition	Alarm output, 2 points Each normally open contact (Make contact) Alarm output, 2 points Each normally close contact (Break contact)	
	Auxiliary supply OFF or relay non-excitation	<p>Terminal No. 7 9 2 5</p> <p>Terminal No. 7 9 2 5</p>	
	Relay excitation	<p>Terminal No. 7 9 2 5</p> <p>Terminal No. 7 9 2 5</p>	
	Output, Contact composition	Alarm output, 2 points (AL1) Normally open contact (Make contact) / (AL2) Normally close contact (Break contact)	
	Auxiliary supply OFF or relay non-excitation	<p>Terminal No. 7 9 2 5</p>	
Relay excitation	<p>Terminal No. 7 9 2 5</p>		

* The terminal number is the number when mounting the socket (FW11 or FW11-W).

5.3 Relay operation

■ Contact delay function

Relay operation in over-input detection. (Output mode : Excitation, H ⁽⁸⁾)

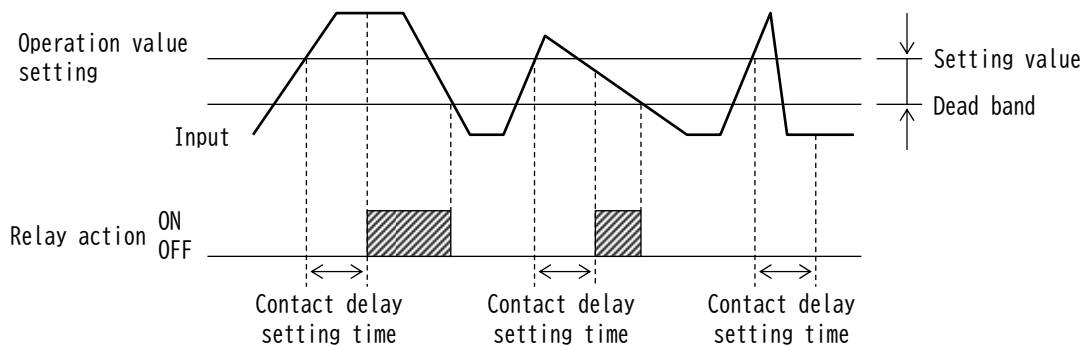

Relay operation in shortage-input detection. (Output mode : Excitation, L ⁽⁸⁾)

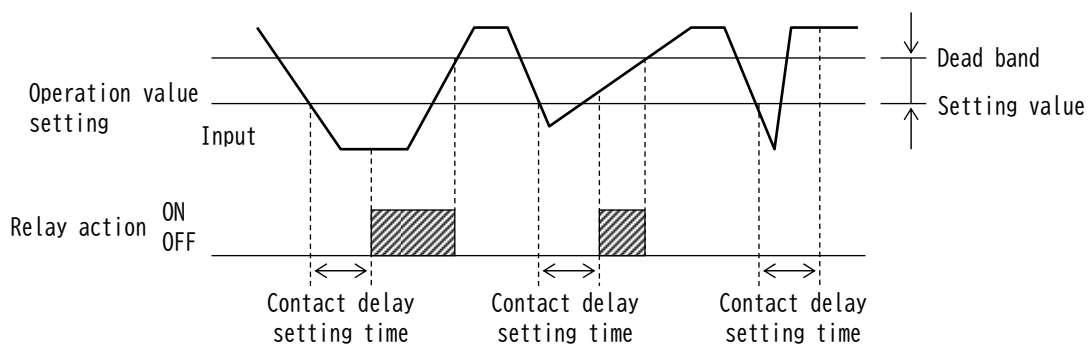

Note⁽⁸⁾ In case of non-excitation for relay excitation operation setting, action of relay becomes reverse.

■ Starting delay function

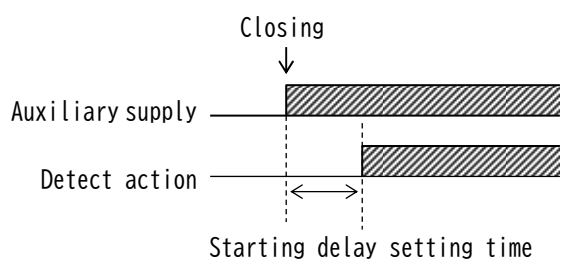

After an auxiliary supply apply, detection action is performed after a starting delay time.

5.4 Pre-alarm function

A monitor lamp is blinked among contact delay time until excitation of a relay after operation value detection. Blinking of a monitor lamp will be gradually fast, and when the point of contact delay time passes, a monitor lamp is lights up.

If contact delay time setting is made into 0 second, a pre-alarm function constitutes OFF.

• Relay action and pre-alarm in over-input detection.

(Output mode setting : Excitation H, Pre-alarm setting : ON)

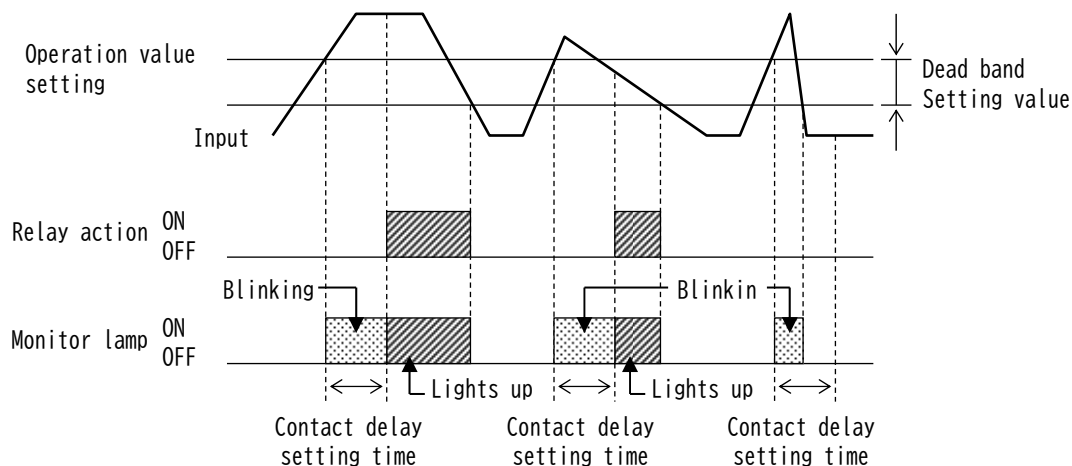

• Action of the pre-alarm in contact delay time (blinking)

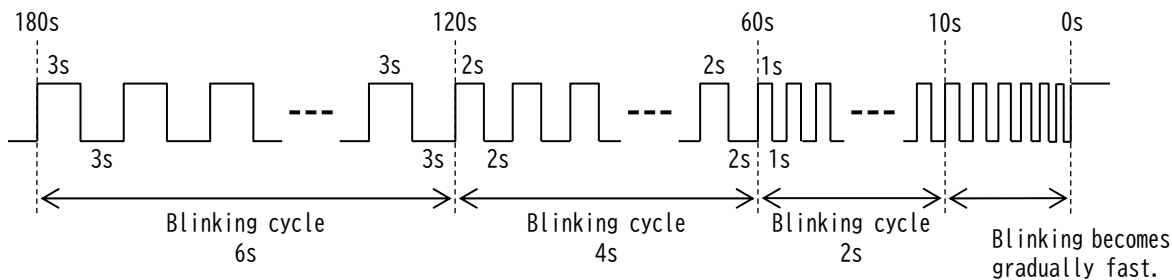

5.5 Setting value

No.	Contents		Mark	Initial value		Setting range
				1 output	2 outputs	
1	Unit display		UNIT	%		Select one point from 129 points (Please refer to the "5.6 Unit" for more information)
2	Scaling ⁽⁹⁾	Minimum value	S. MIN	0.0		-9999 to 9998
3		Maximum value	S. MAX	100.0		-9998 to 9999
4		Decimal point	D. P.	000.0		None decimal point to 3 decimal places
5	Calibration	BIAS	C. BIAS	0.00%		-9.99 to 9.99% (% of input span)
6		SPAN	C. SPAN	0.00%		-9.99 to 9.99% (% of input span)
7	Starting delay time		S. D.	5s		1 to 180s
8	Average number		AVE	1		1, 4, 8, 16, 32
9	Pre-alarm		PRE-AL	OFF		ON : Pre-alarm ON, OFF : Pre-alarm OFF
10	Luminance		LUMI.	3		1 to 5
11	Display off time		AUTO-OFF	10min		1 minutes, 2 minutes, 5 minutes, 10 minutes, 15 minutes, 30 minutes
12	ALARM	Output mode	ALMD	HIGH	—	High : H operation, Low : L operation, OFF : Non-operation
13		Operation value	COMP	70.0	—	With respect to the real scale, within the measurement display range (-25 to + 125%).
14		Dead band	D. B.	3.0%	—	0.5 to 50.0%
15		Excitation mode	EXMD	ON	—	ON : Excitation, OFF : Non-excitation
16		Contact delay time	C. D.	0s	—	0 to 180s
17		Reset method	R. M.	AUTO	—	AUTO, HOLD
18	ALARM1	Output mode	ALMD1	—	HIGH	High : H operation, Low : L operation, OFF : Non-operation
19		Operation value	COMP1	—	70.0	With respect to the real scale, within the measurement display range (-25 to + 125%).
20		Dead band	D. B. 1	—	3.0%	0.5 to 50.0%
21		Excitation mode	EXMD1	—	ON	ON : Excitation, OFF : Non-excitation
22		Contact delay time	C. D. 1	—	0s	0 to 180s
23		Reset method	R. M. 1	—	AUTO	AUTO, HOLD
24	ALARM2	Output mode	ALMD2	—	LOW	High : H operation, Low : L operation, OFF : Non-operation
25		Operation value	COMP2	—	30.0	With respect to the real scale, within the measurement display range (-25 to + 125%).
26		Dead band	D. B. 2	—	3.0%	0.5 to 50.0%
27		Excitation mode	EXMD2	—	ON	ON : Excitation, OFF : Non-excitation
28		Contact delay time	C. D. 2	—	0s	0 to 180s
29		Reset method	R. M. 2	—	AUTO	AUTO, HOLD

Note⁽⁹⁾ When changing the scaling, the alarm action value will also change according to the scaling.

< Notes of setting >

An operation value can be set up in -25 to +125% or -9999 to 9999 (decimal point depends on setting) of the measurement display range.

When changing the scaling, the operation values will also change according to the scaling.

(Example) Input : 4 to 20mA, Operation values : -25.0, Output mode : Low.

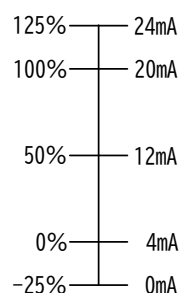

L is detected at input 0 mA and it can be used as disconnection detection.

5.6 Unit

No.	Item	Setting unit							
		μm	mm	cm	m	$\times 10\text{mm}$	$\times 10\text{cm}$		
1	Length	μm	mm	cm	m	$\times 10\text{mm}$	$\times 10\text{cm}$		
2	Mass	mg	g	kg	t	$\times 10\text{kg}$			
3	Time	s	min						
4	Current	mA	A	kA	μA	$\times 10\text{A}$			
5	Temperature	K	$^{\circ}\text{C}$	$\times 10^{\circ}\text{C}$					
6	Angle	$^{\circ}$							
7	Volume	m^3	mL	L	kL	$\times 10\text{L}$	$\times 100\text{L}$		
8	Speed	m/s	mm/min	m/min	mm/h	m/h			
9	Acceleration	m/s^2							
10	Frequency	Hz							
11	Rotational speed	min^{-1}	s^{-1}	rpm	$\times 10\text{rpm}$				
12	Density	mg/L	g/L						
13	Power	N	$\text{N} \cdot \text{m}$	kN					
14	Pressure	Pa	hPa	kPa	MPa	PaG	$\times 10\text{kPa}$		
15	Mass flow	kg/s	kg/min	t/min	mg/h	kg/h	t/h	$\times 10\text{kg/min}$	$\times 10\text{kg/h}$
16	Flow	m^3/s	m^3/min	m^3/h	m^3/d	L/s	mL/min	L/min	L/h
		kL/h	$\times 10\text{t/min}$	$\times 10\text{t/h}$	$\times 10\text{m}^3/\text{min}$	$\times 10\text{kL/h}$	$10^{-1}\text{m}^3/\text{s}$	$\times 10^2\text{m}^3/\text{h}$	
17	Normal	m^3/s (normal)	m^3/min (normal)	m^3/h (normal)	m^3/d (normal)	L/s (normal)	mL/min (normal)	L/min (normal)	L/h (normal)
		kL/h (normal)							
18	Quantity of heat	J	KJ	MJ					
19	Voltage	mV	V	kV					
20	Impedance	Ω	k Ω	M Ω					
21	Conductance	μS	S						
22	Active power	W	kW	MW	mW	$\times 10\text{kW}$	$\times 10\text{MW}$		
23	Electric energy	$\text{W} \cdot \text{h}$	kWh	$\times 10\text{kWh}$					
24	Reactive power	var	kvar	Mvar	$\times 10\text{Mvar}$				
25	Electric conductivity	$\mu\text{S}/\text{cm}$	S/m						
26	Concentration	%	%RH	ppb	ppm	pH	$\times 10\text{ppb}$	$\times 10\text{ppm}$	
27	Datum level	APm	OPm	SPm	TPm	YPm	DLm	ELm	$\times 10\text{TPm}$
28	Other	$\cos\phi$	$\cos\theta$	LAG	LEAD	ϕ			
29	No unit	(NO UNIT)							

<Note 1> Unit is not displayed when no-unit setting is set.

<Note 2> Normal flow rate units are displayed in one step.

5.7 Performance · Class

Item	Specification	
Setting accuracy	Input range	Accuracy
	DC60mV to Less than 1V	±0.2% (% of input span)
	DC±60mV to Less than ±1V	
	DC1 to 60V	±0.1% (% of input span)
	DC±1 to ±60V	
	DC1 to 50mA	
DC±1 to ±50mA		
Display accuracy	Input range	Accuracy
	DC60mV to Less than 1V	When the measurement display span is less than 10000 (5 digits except the decimal point), ±0.2% (% of input span) ±1digit
	DC±60mV to Less than ±1V	When the measurement display span is or 10000 or more (5 digits except the decimal point), ±0.2% (% of input span) ±2digit
	DC1 to 60V	When the measurement display span is less than 10000 (5 digits except the decimal point) ±0.1% (% of input span) ±1digit
	DC±1 to ±60V	
	DC1 to 50mA	When the measurement display span is 10000 or more (5 digits except the decimal point) ±0.1% (% of input span) ±2digit
	DC±1 to ±50mA	
Reproducibility of the operating point	±0.1% (% of input span)	
Operating time	±0.25 seconds of contact delay time set value (However, in case of set value = 0 second. 0.5±0.25 seconds) Average number, N=1 0.5s±0.25s Average number, N=4, 8, 16, 32 $(1/2)N \times 0.1s + 0.5s \pm 0.25s$	
Reset time	Less than 0.5 seconds Since the dead band is% to scaling, the standard values varies depending on the operation values. Average number, N=1 0.5 seconds or less Average number, N=4, 8, 16, 32 $\frac{(4 \text{ times} \times \text{Operating values} (\%) \div 10) \times \text{Dead band} + 1}{\text{Mean measurement data of 4 times} \times \text{Operating values} (\%) \div 10} \times N \times 0.1s + 0.2s \pm 0.25s$ Example) Operating values 70.0 , Dead band 0.5% $\frac{28 \times 0.5 + 1}{4 \times 7} N \times 0.1s + 0.2s \pm 0.25s$	
Starting delay time accuracy	±0.25 seconds of starting delay time set value	
Operation cycle	About 0.1 second	
Display update time	About 0.5 seconds	
Influence of temperature	0.2% (% of input span) / 23±10°C	
Influence of auxiliary supply	0.1% (% of input span) / Within the rated voltage range	
Response time	About 0.5 second In case 90 to 110% of step variation of operation value setting is given, in CD=0 second. If the average number is 1.	

5.8 Electrical strength and mechanical strength

Item		Specification	
Insulation resistance JIS C 1111	1 alarm output	Between electric circuit and case.	Above 50MΩ at DC500V.
		Between input, output and auxiliary supply.	
		Between input and output.	
	2 alarm output	Between electric circuit and case.	
		Between input, output and auxiliary supply.	
		Between AL1 output and AL2 output.	
Power frequency withstand voltage JIS C 1111	1 alarm output	Between electric circuit and case.	AC2210V (50/60Hz) 5 seconds
		Between input, output and auxiliary supply.	
		Between input and output.	
	2 alarm output	Between electric circuit and case.	
		Between input, output and auxiliary supply.	
		Between AL1 output and AL2 output.	
Impulse withstand voltage JIS C 1111		Between electric circuit and case.	5kV 1.2/50μs Both positive and negative polarity for each 3 times.
Vibration JIS C 60068-2-6		Vibration of vibration frequency 16.7Hz, Double amplitude 1mm. In the direction of X Y Z for 10 minutes each.	No malfunction
Shock JIS C 60068-2-27		Shock of 98m/s ² , X, Y, Z direction for each 3 times.	No malfunction
		Shock of 294m/s ² , X, Y, Z direction for each 3 times.	No abnormality
Overload capacity	Voltage input	2 times 10 seconds and 1.5 times continuation of rated voltage.	
	Current input	10 times 5 seconds and 1.5 times continuation of rated current.	
	Auxiliary supply	1.5 times 10 seconds of rated voltage. And upper limit of the variation range is continued.	

5.9 Noise immunity

Item	Specification	
Damped oscillatory wave immunity test	Peak voltage : 2.5kV, Frequency : 1MHz Repeat frequency 6 to 10 times / One cycle of commercial frequency, Continued application for 2 seconds.	No malfunction
Square impulse immunity test	Pulse width 1μs, 100ns width, Repeat cycle 20ms, Application time 5 minutes Auxiliary supply (Normal / Common) 1.0kV or more Output (Common) 1.0kV or more Input (Induction) 1.0kV or more	No malfunction
Radio wave immunity test	Transceiver rated output 1W : 144MHz, 430MHz Radiation direction : X, Y, Z Irradiation distance : 1m	No malfunction
Electrostatic discharge immunity test	Applied by air discharge. Energized : 8kV, Not energized : 10kV 10 times each for positive and negative polarities.	No malfunction

5.10 EMC Directive (CE Marking)

Item	Specification			
Electrostatic discharge immunity test	Contact discharge ±4kV (Charge voltage) Air discharge ±8kV (Charge voltage)	Performance standard : B	After test : Normal operation	EN61000-6-2:2005 EN61000-4-2:2009
Radiated, radio-frequency, electromagnetic field immunity test	Frequency : ① 80 to 1000MHz ② 1.4 to 2.0GHz ③ 2.0 to 2.7GHz Field strength : ① 10V/m ② 3V/m ③ 1V/m Amplitude modulation : 80%AM (1kHz)	Performance standard : A	During test : No malfunction After test : Normal operation	EN61000-6-2:2005 EN61000-4-3:2006 +A2:2010
Electrical fast transient / burst immunity test	Power port : ±2.0kV Contact output : ±1.0kV	Performance standard : B	After test : Normal operation	EN61000-6-2:2005 EN61000-4-4:2012
Surge immunity test	Power port : Line to earth ±0.5kV (DC) Line to line ±0.5kV Power port : Line to earth ±2.0kV (AC) Line to line ±1.0kV DC input : Line to earth ±1.0kV Contact output : Line to earth ±1.0kV	Performance standard : B	After test : Normal operation	EN61000-6-2:2005 EN61000-4-5:2014
Immunity to conducted disturbances, induced by radio-frequency fields	Frequency : 0.15 to 80MHz Voltage level : 10V, 80%AM(1kHz)	Performance standard : A	During test : No malfunction After test : Normal operation	EN61000-6-2:2005 EN61000-4-6:2014
Power frequency magnetic field immunity test	Frequency : 50/60Hz Field strength : 30A/m	Performance standard : A	During test : No malfunction After test : Normal operation	EN61000-6-2:2005 EN61000-4-8:2014
Voltage dips , short interruptions and voltage variations immunity tests (AC power supply)	Residual voltage : 0%, 1 cycle (50/60Hz)	Performance standard : B	After test : Normal operation	EN61000-6-2:2005 EN61000-4-11:2004
	Residual voltage : 40%, 10/12 cycle (50/60Hz)	Performance standard : C		
	Residual voltage : 70%, 25/30 cycle (50/60Hz)			
	Residual voltage : 0%, 250/300 cycle (50/60Hz)			
Electromagnetic radiation disturbance	Frequency band 30 to 230MHz 3m distance : 50dB(μ V/m) or less, 10m distance : 40dB(μ V/m) or less Frequency band 230 to 1000MHz 3m distance : 57dB(μ V/m) or less, 10m distance : 47dB(μ V/m) or less			EN61000-6-4:2007 +A2:2011
Mains terminal disturbance voltage (AC power supply)	Frequency band 0.15 to 0.5MHz Frequency band 0.5 to 30MHz	Quasi-peak : 79dB(μ V) or less, Average : 66dB(μ V) or less Quasi-peak : 73dB(μ V) or less, Average : 60dB(μ V) or less		EN55011:2016 classA, Group1

Performance standard A : During and after the test the equipment shall be able to continue operation as specified.

Performance standard B : The equipment shall be able to continue operation as specified after the test.

However, performance degradation during testing is allowed.

Performance standard C : Temporary loss of function is allowed, but the function can be self-healing or can be recovered by operation of the control device.

5.11 Structure, Use / Storage environmental conditions, Others

Item	Specification
Material	ABS resin
Appearance color	Munsell N1.5 (Black)
External dimensions	29.5mm × 76mm × 125mm (Width × Height × Depth) Including socket
Mass	FSDEL : Approx. 105g , Socket : Approx. 50g
Accessories	Socket : FW11 (OMRON Corporation) ×1 , When socket is unnecessary, please specify at arrangement.
CE marking	EMC Directive (2014/30/EU) Low Voltage Directive (2014/35/EU) EN61010-1
Safety	IEC61010-1 CATIII Maximum use voltage : 264V Pollution degree 2
Operating temperature and humidity limits	-10 to 55°C , 5 to 95% RH (Non condensing)
Storage temperature limits	-25 to 70°C
Power outage guarantee	Each set value is data-saved by non-volatilized memory.

6. Trouble shooting

Symptoms	Possible causes	Remedial measures
Power LED does not light up	Supplementary power supply is not applied to terminals 10 and 11.	Applying the auxiliary supply
Display disappears	By auto off function	Pressing the switch
Display error (Large error)	Auxiliary supply voltage is out of range	Check auxiliary supply voltage
	Input is abnormal	Check input value
	Scaling setting incorrect	Check setting of scaling
Display error (Small error)	Aging of input	Please calibrate the display (Refer to section 3.5 in the operation manual)
Alarm output is not out	Output wiring is incorrect	Check output wiring
	Operation mode setting is OFF	Check setting of operation mode
	The contact delay time is set	Check setting of starting delay time
Alarm output does not return	Reset method is set to hold	Check setting of reset method
	Dead band is big	Check setting of dead band
Error is displayed	RAM ERR	RAM READ/WRITE error
	FRAM ERR	Save data error of the non-volatile memory
	AD ERR	A/D conversion error
		Replace the device

 **DAIICHI ELECTRONICS CO., LTD.**

Tokyo Office : 11-13, Hitotsuya 1-chome, Adachi-ku, Tokyo, 121-8639, JAPAN.
TEL : +81-3-3885-2411 , FAX : +81-3-3858-3966

Kyoto Office : 1-19, Ichinobe-Nishikawahara, Jyoyou-shi, Kyoto, 610-0114, JAPAN.
TEL : +81-774-55-1391 , FAX : +81-774-54-1353

Revision C, DATE : March 26, 2026